

# Standard Details



March 1993

CITY OF MARTINEZ  
DEPARTMENT OF PUBLIC SERVICES

DESIGN CRITERIA

=====

DATE REVISED:

- I. GENERAL CRITERIA AND GENERAL NOTES
- II. STREET DESIGN CRITERIA
- III. STORM DRAIN DESIGN CRITERIA (ONE PAGE)
- IV. WATER SYSTEM DESIGN GUIDELINES AND SPECIFICATIONS.

\_\_\_\_\_

\_\_\_\_\_

JUNE, 1990

JUNE, 1990

STANDARD DRAWINGS

=====

	<u>STANDARD NO.</u>	<u>TITLE</u>	<u>DATE APPROVED:</u>
<u>STREET STANDARDS:</u>	S-1	STREET SECTIONS	5-2-90
	S-2	CURB DETAILS	5-2-90
	S-3	SIDEWALK DETAILS	5-7-90
	S-4	CONSTRUCTION JOINTS	5-7-90
	S-5	CURB & GUTTER REPLACEMENT	5-2-90
	S-6	RESIDENTIAL DRIVEWAY	9-24-91
	S-7	COMMERCIAL DW-TYPE 1	5-2-90
	S-8	COMMERCIAL DW-TYPE 2	5-2-90
	S-9	CONCRETE VALLEY GUTTER	5-2-90
	S-10A, B	STANDARD HANDICAP RAMP	5-2-90
	S-11A, B, C, D	STANDARD TRENCH BACKFILL	9-24-91
	S-12	SURVEY MONUMENT	5-2-90
	S-13A, B	SIDEWALK CROSS DRAIN	5-2-90
	S-14	PARKWAY OBSTRUCTION LOCATION	5-2-90
	S-15	CUL-DE-SAC AND TURN-AROUND	5-2-90
	CC-203	DRIVEWAY GRADE DESIGN	5-2-90
 <u>TRAFFIC STANDARDS:</u>	T-1	STREET SIGN INSTALLATION	5-30-90
	T-2	STREET BARRICADE	5-30-90
	T-3	MOTORCYCLE BARRIER	5-30-90
	T-4	STREET LIGHT INSTALLATION	6-20-90
	T-5	INTERSECTION SIGHT DISTANCE	5-30-90
	T-6	PRIVATE PROPERTY PARKING SIGN	5-30-90
	T-7	HANDICAP PARKING	5-30-90
	T-8	STREET NAME SIGN	6-21-90
	A20A, B, C	CALTRANS STRIPING & PAVEMENT MARKINGS	PER CALTRANS

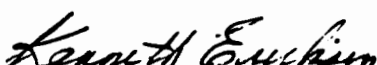
APPROVED BY:  CITY ENGINEER R.C.E. 13456	DATE: 2/22/94	CITY OF MARTINEZ  <h1 style="margin: 0;">INDEX</h1>	SCALE: NONE STD. DRWG. NO.  SHEET 1 OF 2
---	---------------	---	--

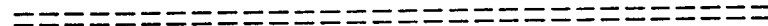

	<u>STANDARD NO.</u>	<u>TITLE</u>	<u>DATE APPROVED</u>
<u>STORM DRAIN STANDARDS:</u>	CC-3013	TYPE "C" INLET	PER CO.
	CC-3016	TYPE "D" INLET	PER CO.
	CC-3017-MODIFIED	TYPE "E" INLET-WITH A WELD	PER CO.
	CC-3020	TYPE I BASE	PER CO.
	CC-3021	TYPE II BASE	PER CO.
	CC-3022	TYPE III BASE	PER CO.
	CC-3024	MANHOLE FRAME AND COVER	PER CO.
	CC-3025	TYPE IV BASES	PER CO.
	B-58	CONCRETE INTERCEPTOR DITCH	PER CO.
<u>LANDSCAPING:</u>	L-1	TREE PLANTING DETAIL	5-30-90
<u>IRRIGATION:</u>	I-1	MEDIAN CONTROLLER ENCLOSURE	12-22-93
	I-2	REDUCED PRESSURE BACKFLOW	12-22-93
	I-3	REMOTE CONTROL VALVE	12-22-93
	I-4	GATE VALVE	12-22-93
	I-5	DRIP SYSTEM FILTER ASSEMBLY	12-22-93
	I-6	QUICK COUPLING VALVE	12-22-93
	I-7	BUBBLER AT LAWN TREES & STREET TREES	12-22-93
	I-8	STREAM ROTOR POP - UP	12-22-93
<u>WATER STANDARDS:</u>	W-1	STANDARD 1" & 2" SERVICE CONNECTIONS	12-22-88
	W-2	STANDARD 5/8" TO 2" METER INSTALLATIONS	12-22-88
	W-3	3" COMPOUND METER - ABOVE GROUND	12-22-88
	W-4	4" COMPOUND METER - ABOVE GROUND	12-22-88
	W-5	4" COMPOUND METER AND BACKFLOW PREVENTION DEVICE - BELOW GROUND	12-22-88
	W-6	DUAL 1-1/2" & 2" METER INSTALLATION SERVICE	12-22-88
	W-7	BLOCKING DETAILS	12-22-88
	W-8	STANDARD VALVE AND HYDRANT	12-22-88
	W-9	STANDARD VALVE BOX	12-22-88
	W-10	STANDARD BLOWOFF	12-22-88
	W-11	DOUBLECHECK VALVE - DETECTOR CHECK ASSEMBLY	12-22-88
	W-12	SINGLE CHECK VALVE - DETECTOR CHECK ASSEMBLY	9-91
	W-13	3" & LARGER BACKFLOW PREVENTION DEVICE	12-22-88
	W-14	SCHEMATIC BOOSTER PUMP INSTALLATION	12-22-88
	W-15	ZONE VALVE ASSEMBLY	12-22-88
	W-16	PROTECTIVE ENCLOSURE	12-22-88
	W-17	AIR & VACUUM RELIEF VALVE ASSEMBLY	9-91
	W-18	SWING CONNECTION TO 4" & SMALLER PIPE	12-22-88
	W-19	3/4" TO 2" BACKFLOW PREVENTION DEVICE	12-22-88

APPROVED BY:  CITY ENGINEER R.C.E. 13456	DATE: 2/22/94	CITY OF MARTINEZ	SCALE: NONE
	INDEX		STD. DRWG. NO.
			SHEET 2 OF 2

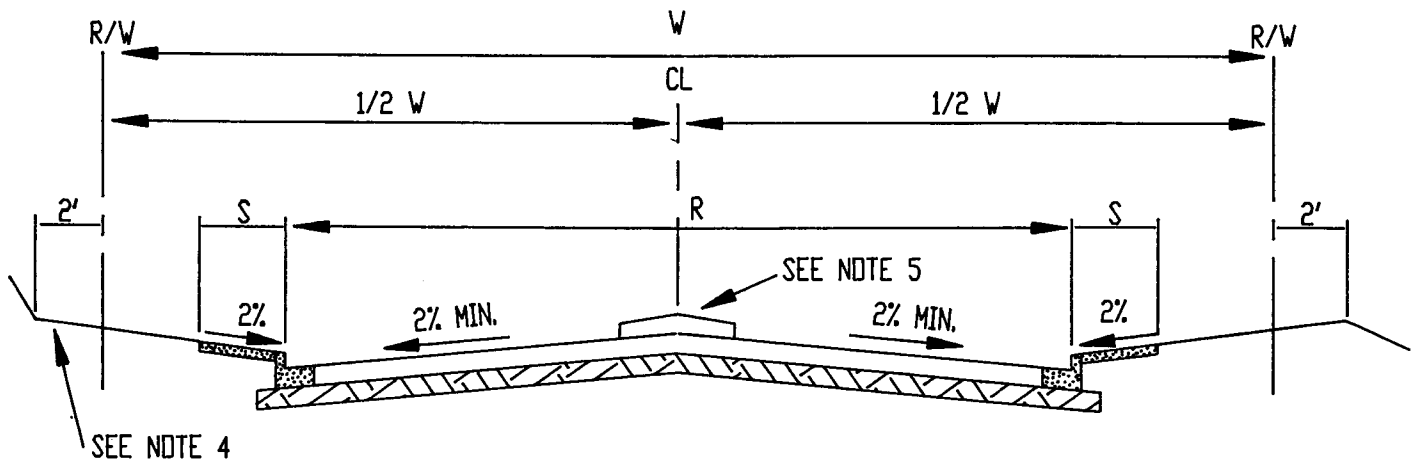

TYPICAL SECTION

LEGEND

- W = WIDTH OF RIGHT OF WAY
- R = WIDTH OF ROADWAY
- S = WIDTH OF SIDEWALK
- T.I. = TRAFFIC INDEX
- R/W = RIGHT OF WAY

CLASSIFICATION	PARKING	SIDEWALK	W	W*	R	S	DESIGN SPEED	T.I.	MIN. SECTION
ARTERIAL	BOTH	BOTH	100'	94'	80'	7'	40-55	8.5	0.4' AC
COLLECTOR	BOTH	BOTH	60'	54'	40'	5.5'	30-40	7.0	0.3' AC
LOCAL	BOTH	BOTH	56'	50'	36'	5.5'	25-30	5.5	0.2' AC
HILLSIDE LOCAL	ONE SIDE	ONE SIDE	40'	40'	28'	5.5'	25	5.5	0.2' AC

NOTES:

1. W\* APPLIES WITH SPECIAL APPROVAL OF PLANNING COMMISSION ONLY.
2. REQUIRED STRUCTURAL SECTION DETERMINED BY SOILS R-VALUE TEST AND BY T.I. MINIMUM SECTION IS A.C. THICKNESS SHOWN OVER 0.5' CLASS 2 CALTRANS STANDARD AGGREGATE BASE.
3. CURBS SHALL BE TYPE 'A' UNLESS OTHERWISE APPROVED BY THE CITY.
4. DISTANCE SHOWN IS MINIMUM FROM R/W TO HINGE POINT.
5. MEDIAN ISLANDS 16' WIDE OR LESS ARE REQUIRED FOR SELECTED STREETS.
6. SIDEWALK DETAILS SEE STANDARD DRAWING S-3.
7. STREET GRADES: 0.5% - MIN, 10% - MAX. (15% FOR LOCAL STREETS).
8. ADDITIONAL R/W & R FOR BUS STOPS, TURN LANES, ETC. SHALL BE CONSIDERED ON A CASE BY CASE BASIS.
9. MATERIAL SHALL BE SCARIFIED AND COMPACTED TO 95% RELATIVE COMPACTION FOR A MINIMUM DEPTH OF 0.5 FT. BELOW SUBGRADE.



APPROVED BY: *Richard K. Cullen* DATE: 5/2/90  
 PUBLIC SERVICES DIRECTOR R.C.E. 23797

CITY OF MARTINEZ  STREET SECTIONS	SCALE: NONE
	STD. DRWG. NO. S-1
SHEET 1 OF 1	



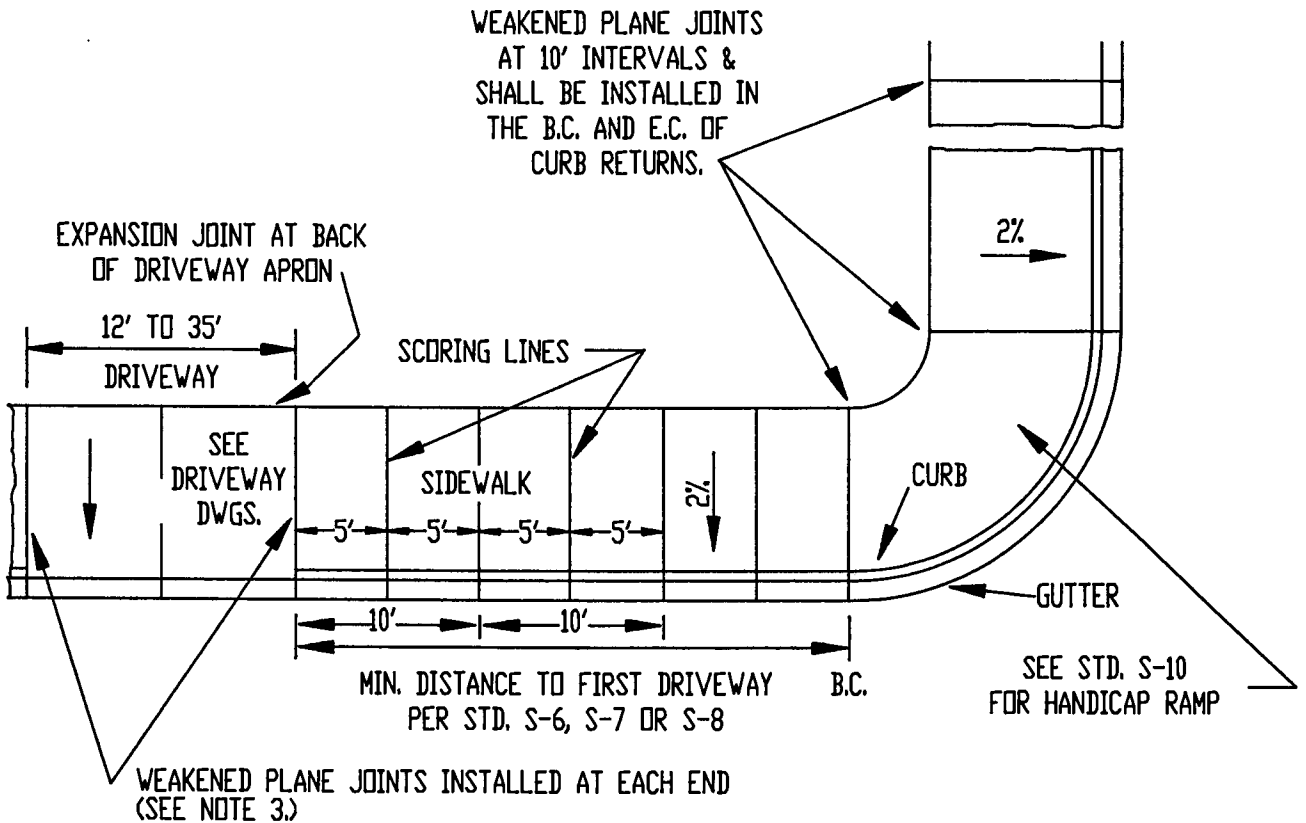

NOTES:

1. CONCRETE SHALL BE: 2500 P.S.I. 520 LBS. CEMENT/CUBIC YARD, 4 IN. MAXIMUM SLUMP.
2. STANDARD THICKNESS IS 3.5 IN. CONCRETE WITH 3 IN. CLASS 2 CALTRANS STANDARD AGGREGATE BASE CUSHION.
3. INSTALL WEAKENED PLANE JOINTS AT 10' INTERVALS, AT ALL RADIUS POINTS, AT MIDPOINT OF 24' OR WIDER DRIVEWAYS, AND AS REQUIRED BY THE CITY. DEPTH SHALL BE 2 IN.. APWA APPROVED PLASTIC CONTROL JOINTS MAY BE USED.
4. INSTALL TOOL SCORE LINES AT 5' INTERVALS, 1/4 IN. DEEP AND EXTEND ACROSS SIDEWALK, CURB & GUTTER. A LONGTUDINAL SCORE LINE IS REQUIRED DOWN THE CENTER OF ANY SIDEWALK 8' OR WIDER.
5. FOR SIDEWALK ADJACENT TO CURB, MAINTAIN 5.5' WIDTH FROM CURB FACE FOR RESIDENTIAL AREAS AND 7' WIDTH FOR ARTERIALS, COMMERCIAL AREAS, OR DOWNTOWN BUSINESS DISTRICT. MAINTAIN 4' MIN. CLEAR WIDTH PER STD. DRWG. S-14.
6. CURB, GUTTER AND SIDEWALK MAY BE MONOLITHIC WHEN APPROVED BY THE CITY.
7. REFER TO STANDARD DRAWING S-4 FOR INSTALLING NEW SIDEWALK ADJACENT TO EXISTING.



APPROVED BY: *Richard R. Cullen* DATE: 5/7/90  
 PUBLIC SERVICES DIRECTOR R.C.E. 23797

CITY OF MARTINEZ  
 SIDEWALK DETAILS

SCALE: NONE  
 STD. DRWG. NO. S-3  
 SHEET 1 OF 1

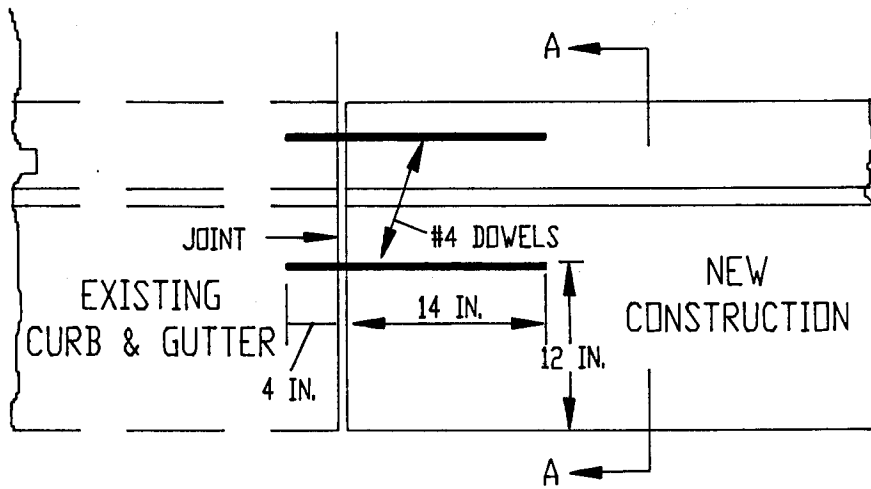

CURB & GUTTER

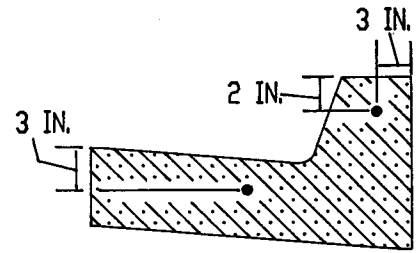

SECTION A-A

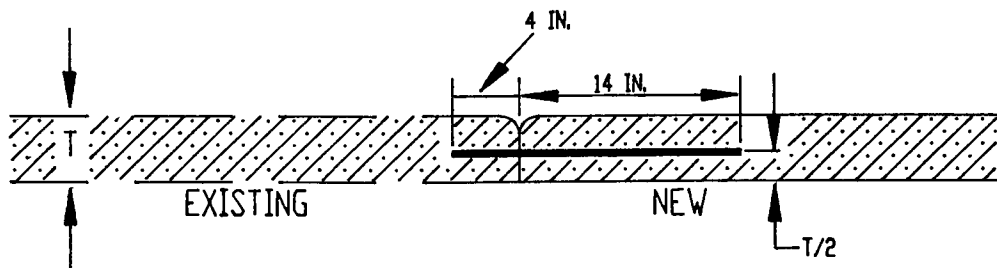
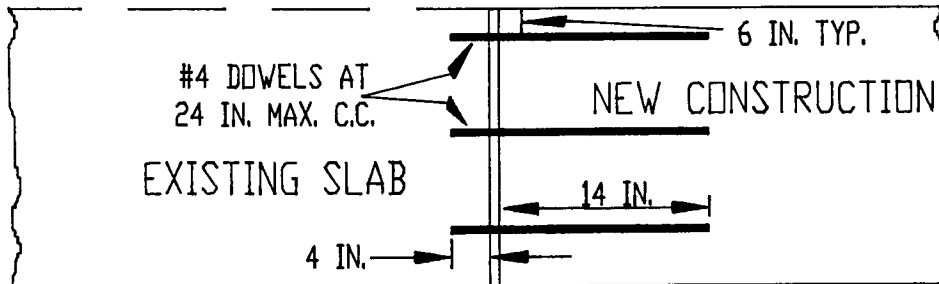

PCC SLABS

NOTES:

1. DOWELED CONSTRUCTION JOINTS SHALL BE REQUIRED IN CURB & GUTTER, SIDEWALKS, DRIVEWAYS AND VALLEY GUTTERS WHENEVER NEW CONCRETE IS POURED AGAINST EXISTING CONCRETE.
2. SECTION TO BE REPLACED SHALL BE TO THE NEAREST SCORE LINES.



APPROVED BY: *Richard P. Cullen* DATE: 5/7/90  
 PUBLIC SERVICES DIRECTOR R.C.E. 23797

CITY OF MARTINEZ  
 CONSTRUCTION  
 JOINT

SCALE: NONE  
 STD. DRVG.  
 NO.  
 S-4  
 SHEET 1 OF 1

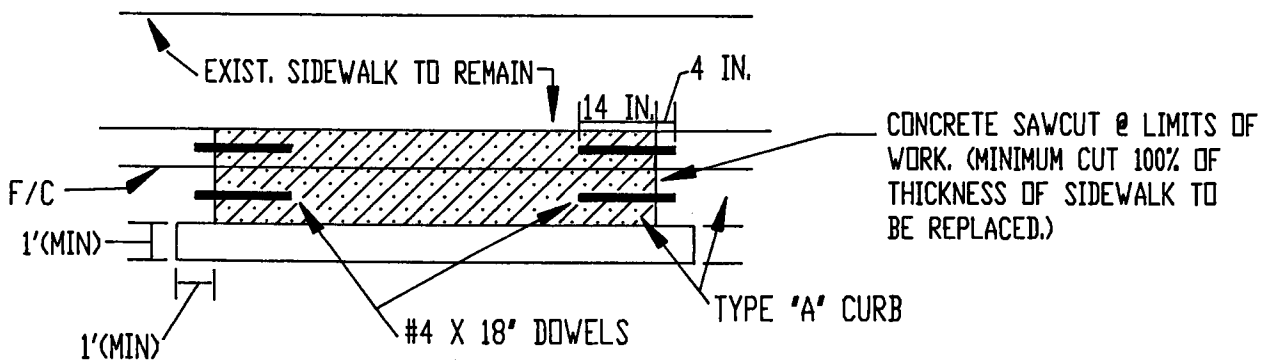
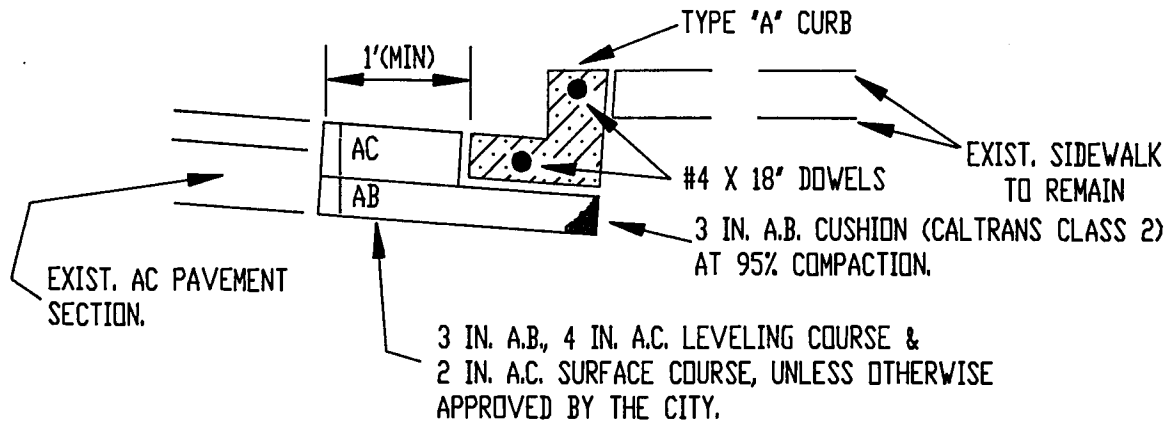

NOTES:

1. MINIMUM WIDTH SHALL ALLOW COMPACTION OF AGGREGATE BASE WITH MECHANICAL EQUIPMENT AS APPROVED BY THE CITY.
2. EXTEND 3 IN. A.B. CUSHION 6 IN. BEHIND BACK OF CURB WHEN NO SIDEWALK IS ADJACENT TO BACK OF CURB.
3. CONCRETE SHALL BE POURED AGAINST A FORM BOARD.
4. SECTION TO BE REPLACED SHALL BE TO THE NEAREST SCORE LINES.

**\*\*ALTERNATE REMOVAL METHOD\*\***

1. WITH PRIOR APPROVAL, IN WRITING, OF THE CITY, THE REQUIREMENT FOR 1' A.C. REMOVAL MAY BE WAIVED.
2. A FULL DEPTH SAWCUT SHALL BE MADE AT THE EXISTING GUTTER LIP PRIOR TO REMOVAL.
3. UNSATISFACTORY WORK DUE TO UNEVEN SAWCUT, RAVELLING OF A.C., AND IMPROPER WORK SHALL REQUIRE REMOVAL AND REPLACEMENT WITH 1' A.C. SECTION.



APPROVED BY: *Richard P. Cullen* DATE: 5/2/90  
 PUBLIC SERVICES DIRECTOR R.C.E. 23797

CITY OF MARTINEZ  
 CURB & GUTTER  
 REPLACEMENT

SCALE: NONE  
 STD. DRWG.  
 NO.  
 S-5  
 SHEET 1 OF 1



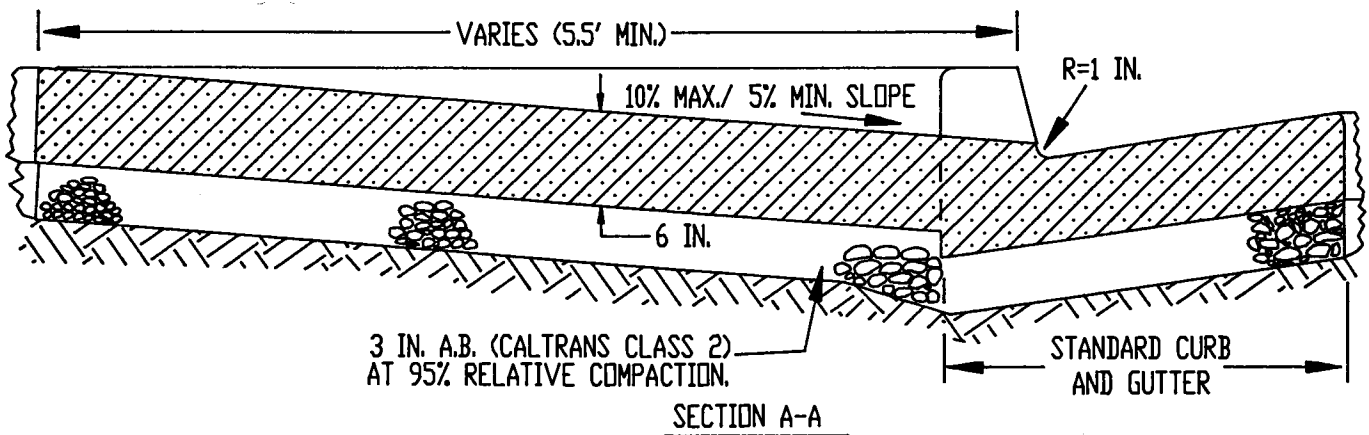
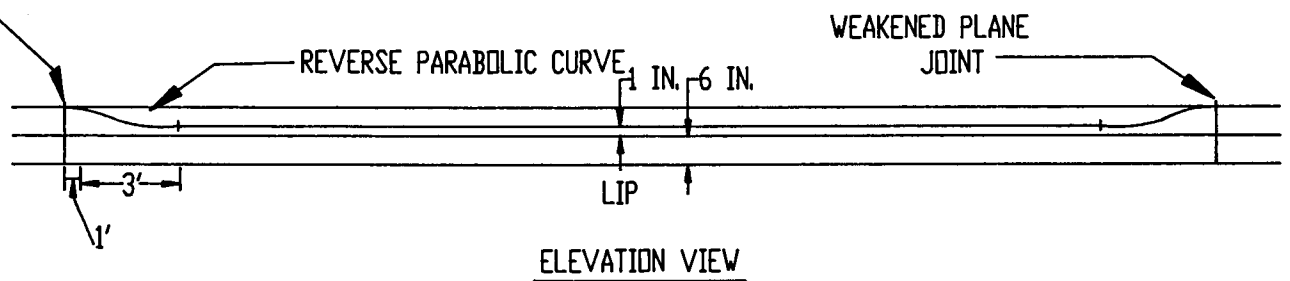
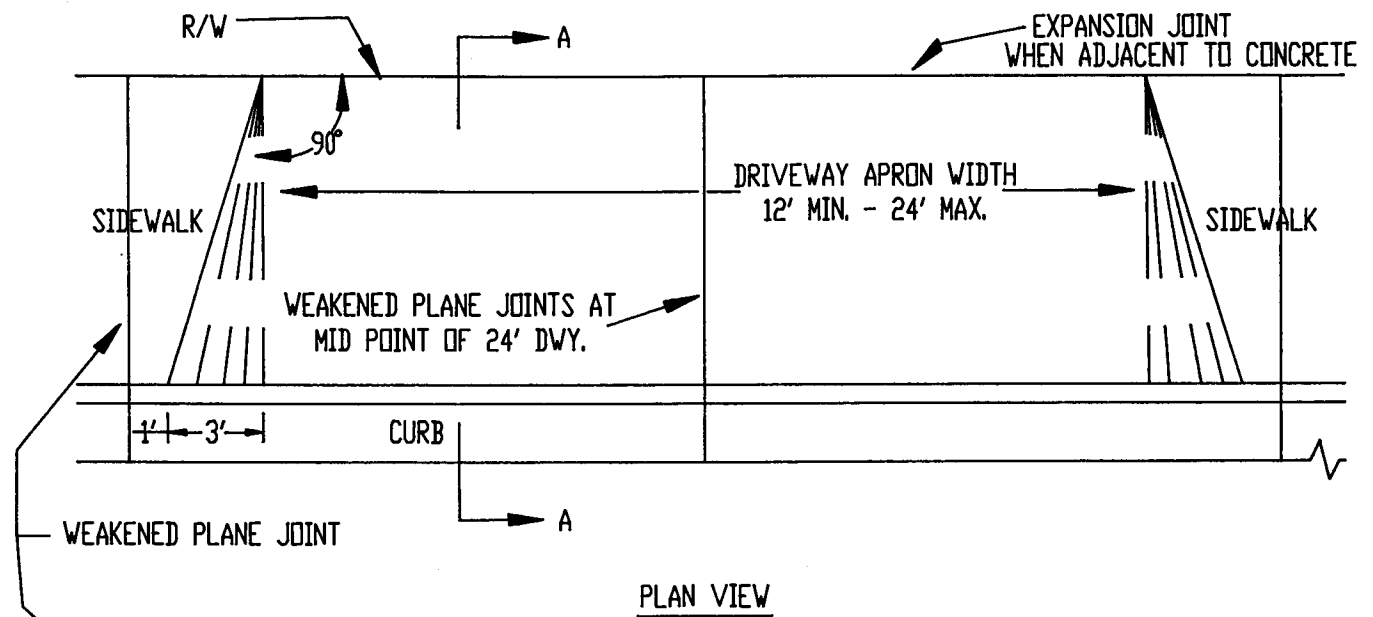

NOTES:

1. CONCRETE SHALL BE: 2500 P.S.I., 520 LBS. CEMENT/CUBIC YARD, 4 IN SLUMP.
2. A MINIMUM 5' CLEARANCE IS REQUIRED FROM TOP OF DRIVEWAY FLARE TO PARKWAY OBSTRUCTIONS (POLE, TREE, ETC.).
3. NO MORE THAN ONE DRIVEWAY FOR EVERY 100' OF FRONTAGE.
4. MINIMUM DISTANCE BETWEEN TOP OF DRIVEWAY FLARES IS 5'.  
WHERE POSSIBLE ELIMINATE ADJACENT FLARES WITH COMMON DRIVEWAY.
5. MINIMUM DISTANCE FROM TOP OF DRIVEWAY FLARE TO NEAREST CURB RETURN IS 25'.
6. INSTALL 1/4 IN. EXPANSION JOINTS ALONG REAR OF DRIVEWAY APRON USING A.P.W.A. APPROVED PREMOLDED FILLER WHEN ADJACENT TO CONCRETE.



APPROVED BY: *Richard K. Cullen* DATE: 5/2/90  
 PUBLIC SERVICES DIRECTOR R.C.E. 23797

CITY OF MARTINEZ  
 RESIDENTIAL  
 DRIVEWAY

SCALE: NONE  
 STD. DRVG.  
 NO.  
 S-6  
 SHEET 1 OF 1

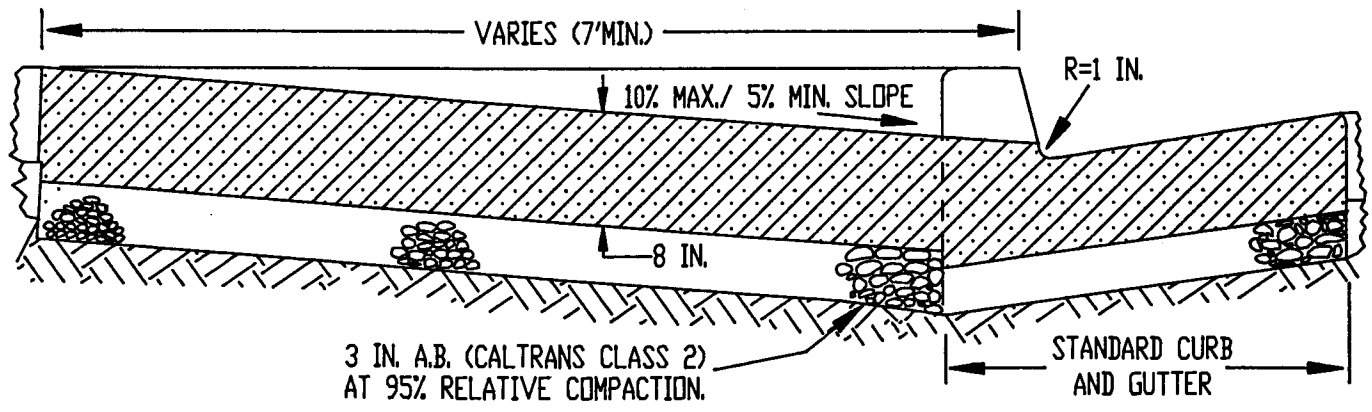
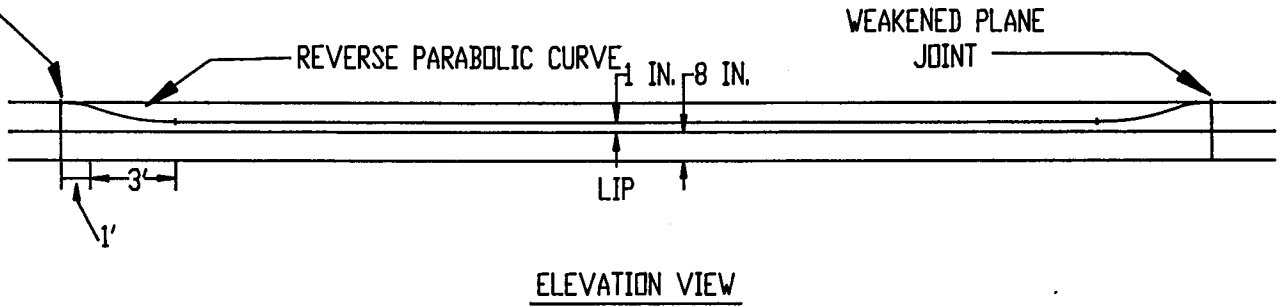
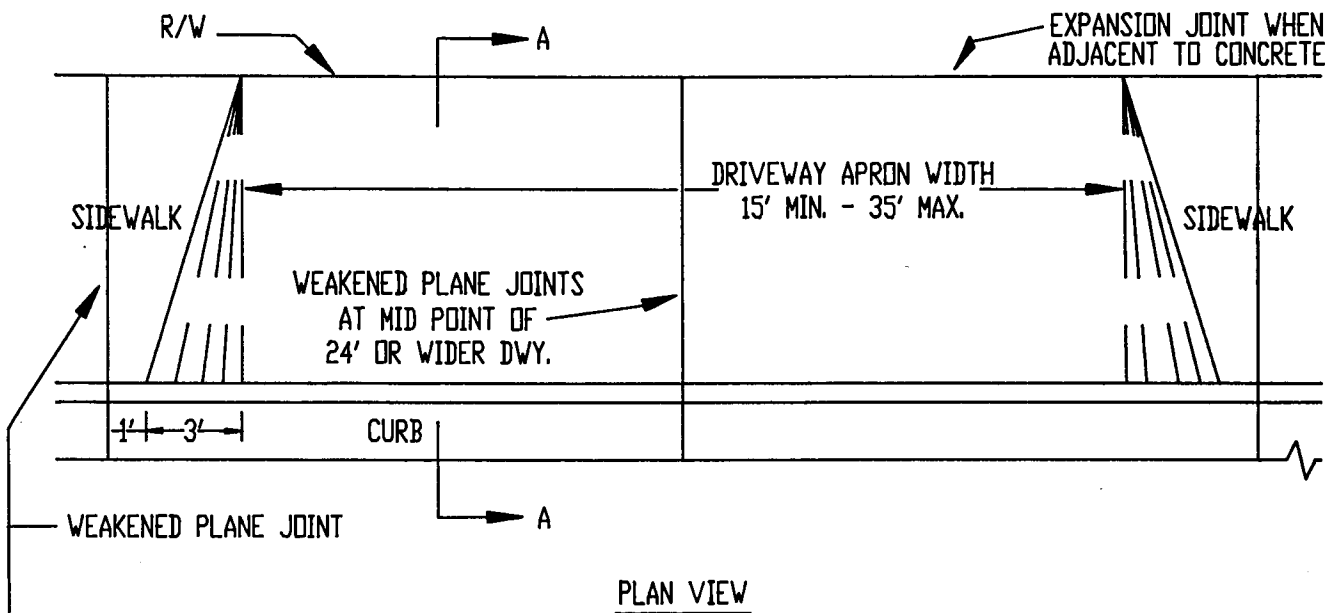

SECTION A-A

NOTES:

1. CONCRETE SHALL BE: 2500 P.S.I., 520 LBS. CEMENT/CUBIC YARD, 4 IN. SLUMP.
2. A MINIMUM 5' CLEARANCE IS REQUIRED FROM TOP OF DRIVEWAY FLARE TO PARKWAY OBSTRUCTIONS (POLE, TREE, ETC.).
3. NO MORE THAN ONE DRIVEWAY FOR EVERY 100' OF FRONTAGE.
4. MINIMUM DISTANCE BETWEEN TOP OF DRIVEWAY FLARES IS 22'.  
WHERE POSSIBLE ELIMINATE ADJACENT FLARES WITH COMMON DRIVEWAY.
5. MINIMUM DISTANCE FROM TOP OF DRIVEWAY FLARE TO NEAREST CURB RETURN IS 50'.
6. INSTALL 1/4 IN. EXPANSION JOINTS ALONG REAR OF DRIVEWAY APRON USING A.P.W.A. APPROVED PREMOULDED FILLER WHEN ADJACENT TO CONCRETE.

	APPROVED BY: <i>Richard R. Cullen</i> PUBLIC SERVICES DIRECTOR R.C.E. 23797	DATE: 5/2/90	CITY OF MARTINEZ <b>COMMERCIAL DRIVEWAY</b> TYPE 1	SCALE: NONE STD. DRWG. NO. <b>S-7</b>
				SHEET 1 OF 1

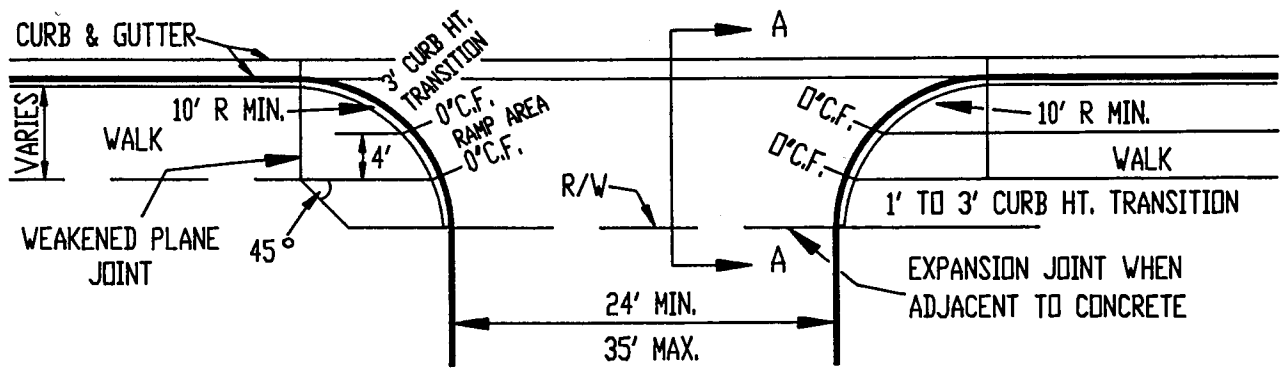

PLAN VIEW

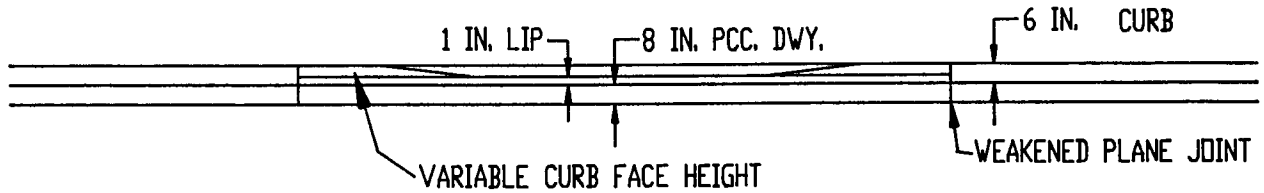

ELEVATION VIEW

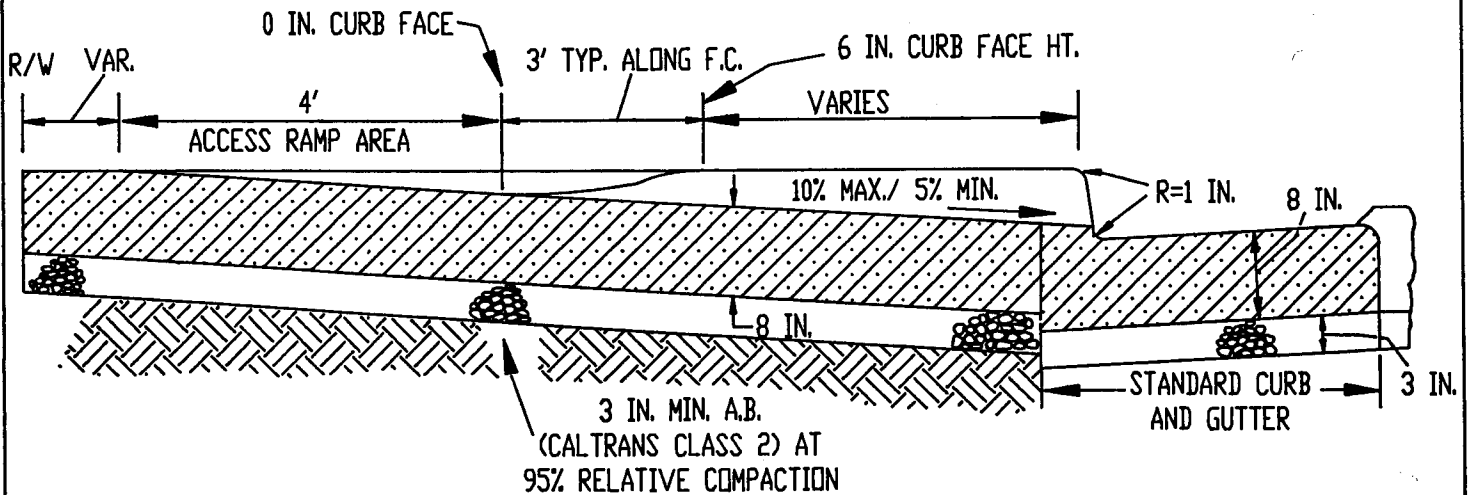

SECTION A-A

NOTES

1. CONCRETE SHALL BE: 2500 P.S.I., 520 LBS. CEMENT/CUBIC YARD, 4 IN. MINIMUM SLUMP.
2. A MINIMUM 5' CLEARANCE IS REQUIRED FROM TOP OF DRIVEWAY FLARE TO PARKWAY OBSTRUCTIONS (POLE, TREE, ETC.)
3. NO MORE THAN ONE DRIVEWAY FOR EVERY 100' OF FRONTAGE.
4. MINIMUM DISTANCE BETWEEN TOP OF DRIVEWAY FLARES IS 35'. WHERE POSSIBLE ELIMINATE ADJACENT FLARES WITH COMMON DRIVEWAY.
5. MINIMUM DISTANCE FROM TOP OF DRIVEWAY FLARE TO NEAREST CURB RETURN IS 100'.
6. INSTALL 1/4 IN. EXPANSION JOINTS ALONG REAR OF DRIVEWAY APRON USING A.P.W.A. APPROVED PREMOLDED FILLER WHEN ADJACENT TO CONCRETE.



APPROVED BY:

DATE: 5/2/90

*Richard K. Cullen*  
PUBLIC SERVICES DIRECTOR R.C.E. 23797

CITY OF MARTINEZ

COMMERCIAL  
DRIVEWAY  
TYPE 2

SCALE: NONE  
STD. DRWG.  
NO.  
S-8

SHEET 1 OF 1

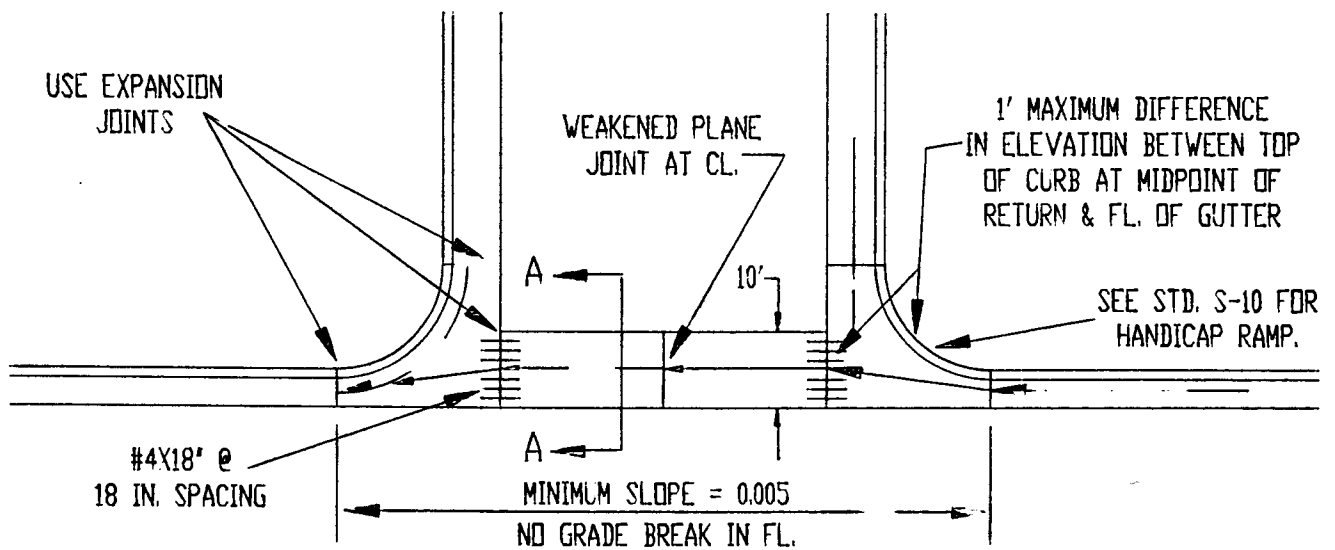

PLAN VIEW

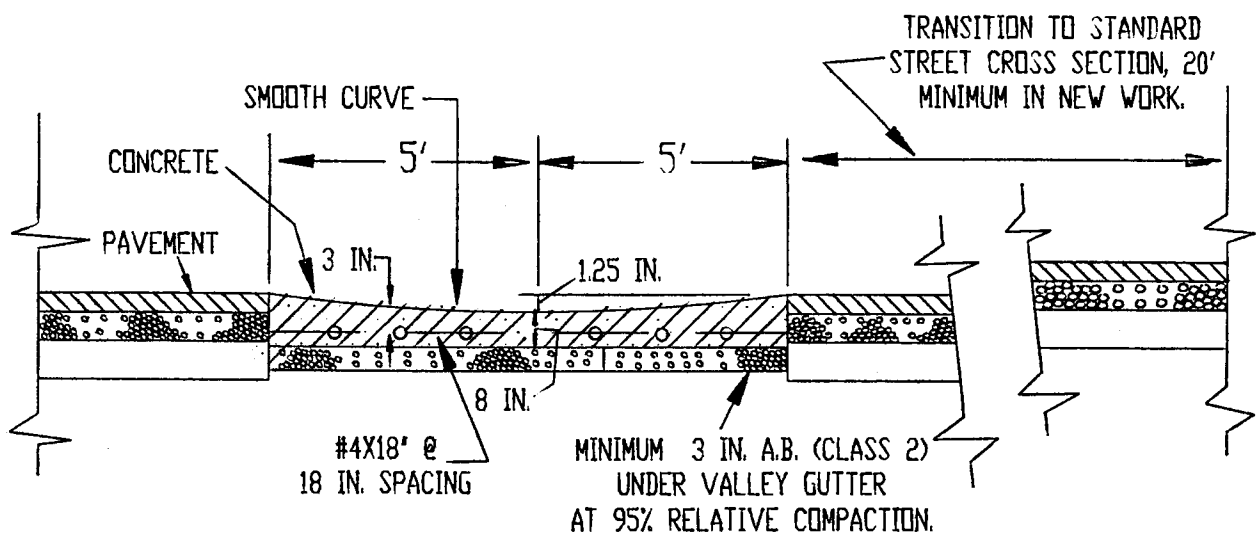

SECTION A-A

NOTES:

1. CONCRETE SHALL BE: 2500 P.S.I., 520 LBS. CEMENT/CUBIC YARD AND 4 IN. MAXIMUM SLUMP.
2. VALLEY GUTTERS ARE PERMITTED ONLY WITH THE APPROVAL OF THE CITY.



APPROVED BY:

DATE: 5/2/90

*Richard R. Cullen*  
PUBLIC SERVICES DIRECTOR R.C.E. 23797

CITY OF MARTINEZ

CONCRETE VALLEY  
GUTTER

SCALE: NONE

STD. DRWG.

NO.

S-9

SHEET 1 OF 1

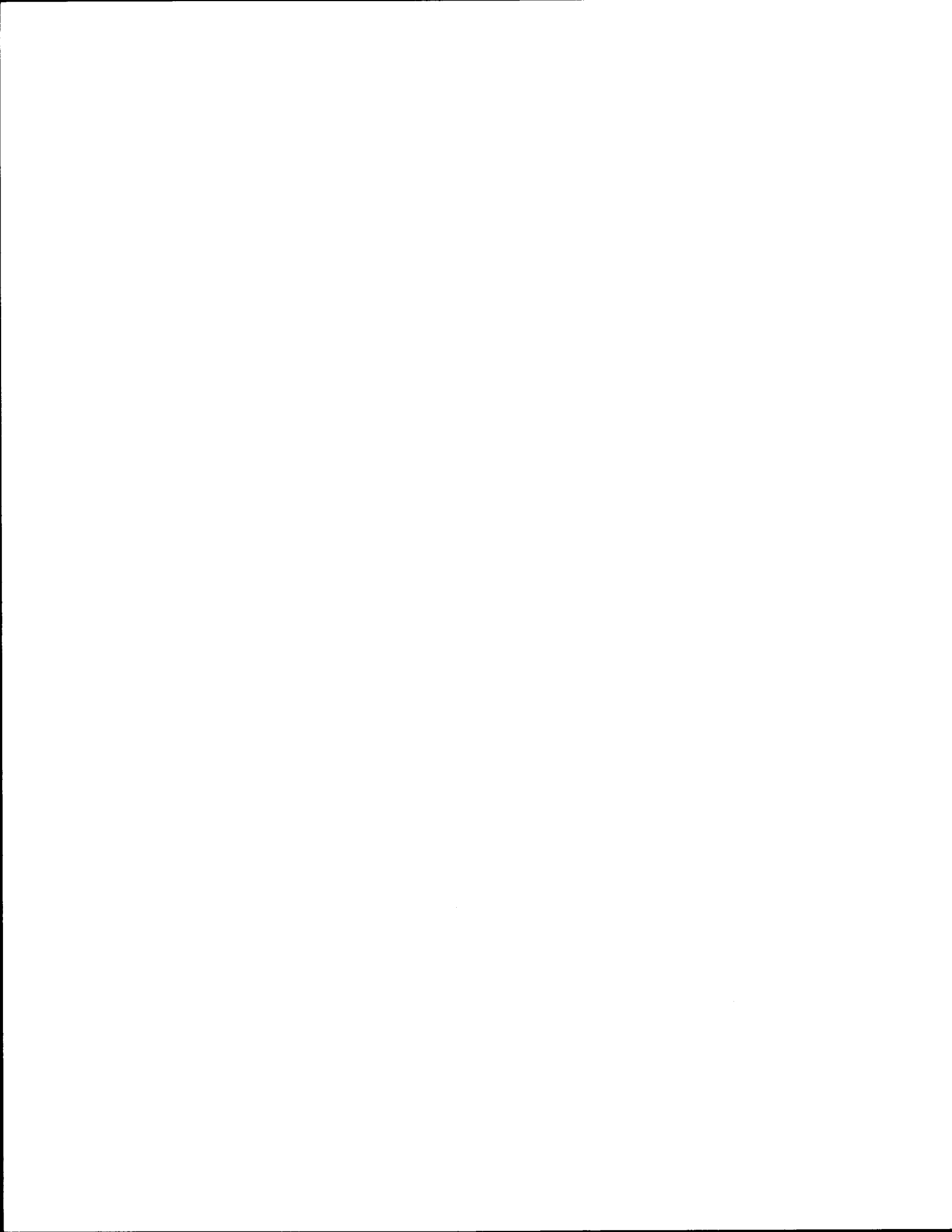

SCORING FOR A WIDTH OF 12 IN.  
1/4 IN. DEEP X 1/4 IN. WIDE  
3/4 IN. APART

LOCATE AT INTERSECTION MID. PT. OF  
RETURN UNLESS OTHERWISE NOTED ON  
PLANS OR DIRECTED BY THE ENGINEER.

1/4 IN. DEEP X 1/4 IN. WIDE  
GROOVES @ 1.5 IN. O.C. ALIGNED  
PARALLEL TO CROSSWALK.

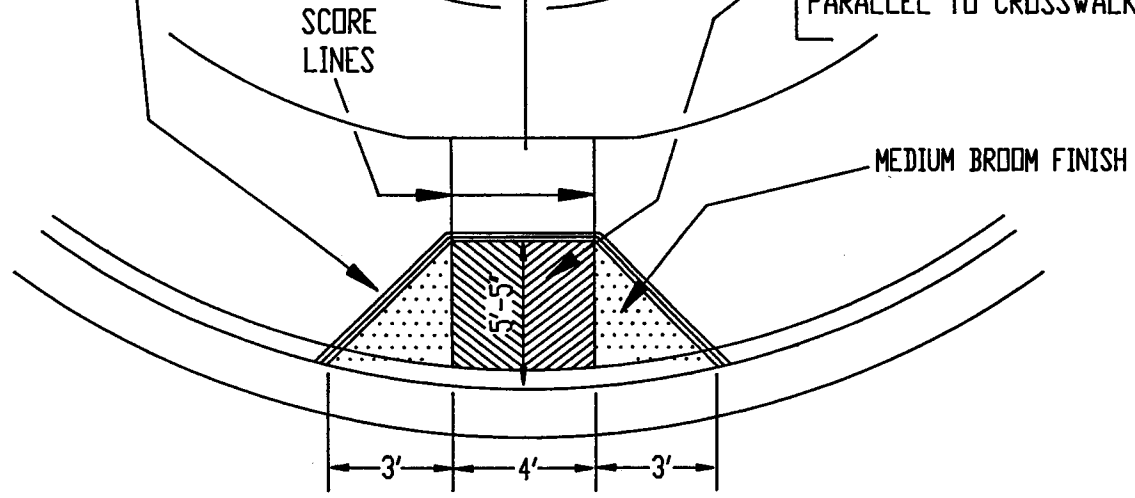

PLAN

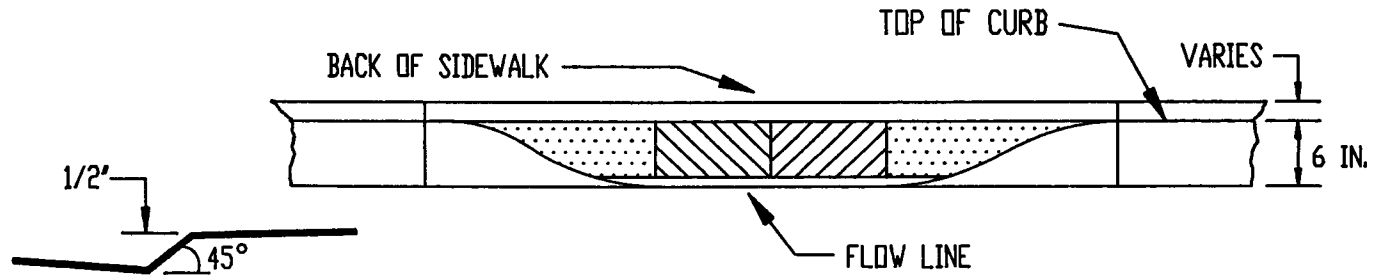

ELEVATION

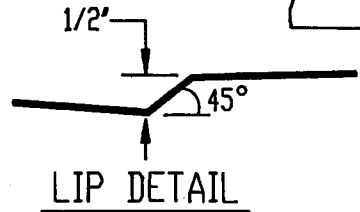

LIP DETAIL

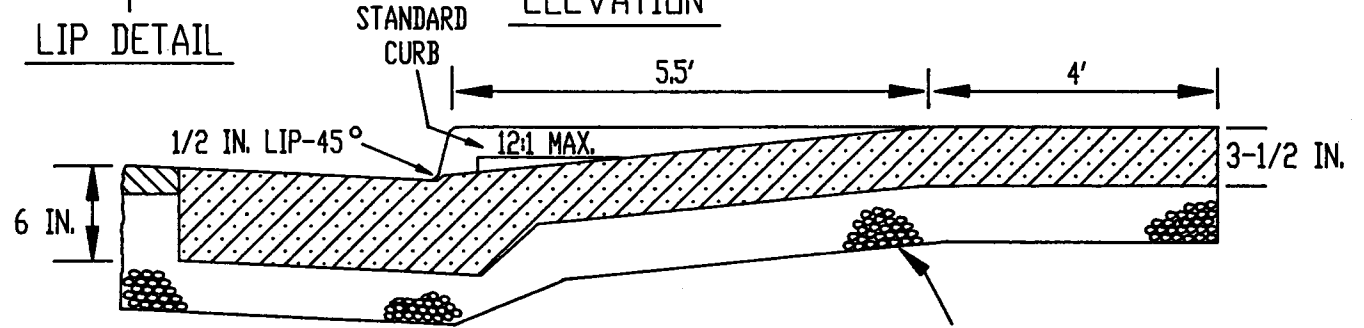

SECTION

NOTES:

1. CLASS OF CONCRETE SHALL BE: 520-C-2500; 520 LBS. CEMENT/CUBIC YARD, 2500 P.S.I. AND 4 IN. MAXIMUM SLUMP.
2. WHERE 4' PLATFORM IS NOT FEASIBLE, THE WIDTH MAY BE DECREASED AS DIRECTED BY THE CITY.



APPROVED BY: *Richard R. Colten* DATE: 5/2/90  
PUBLIC SERVICES DIRECTOR R.C.E. 23797

CITY OF MARTINEZ  
STANDARD  
HANDICAP RAMP  
CASE A

SCALE: NONE  
STD. DRWG. NO. S-10A  
SHEET 1 OF 2

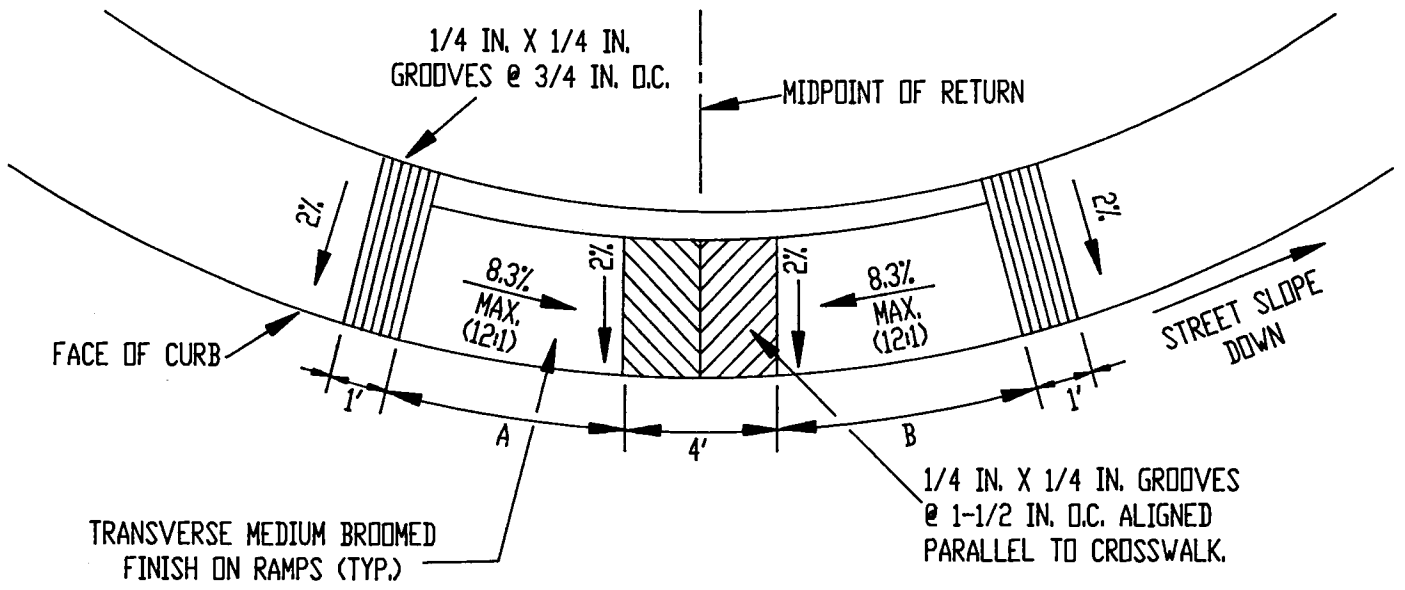

PLAN

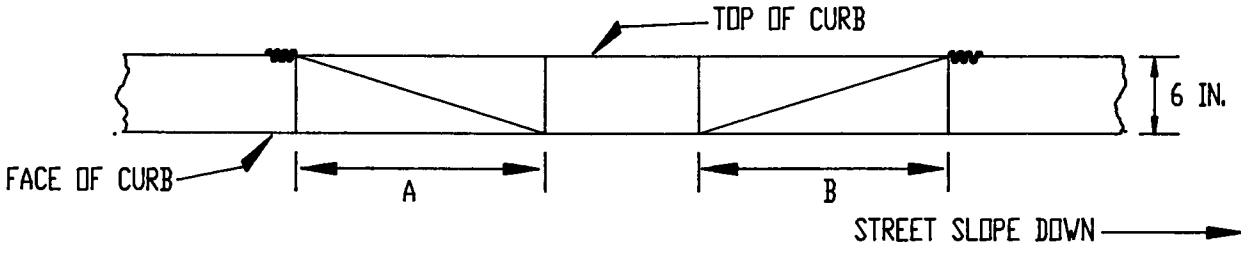

ELEVATION

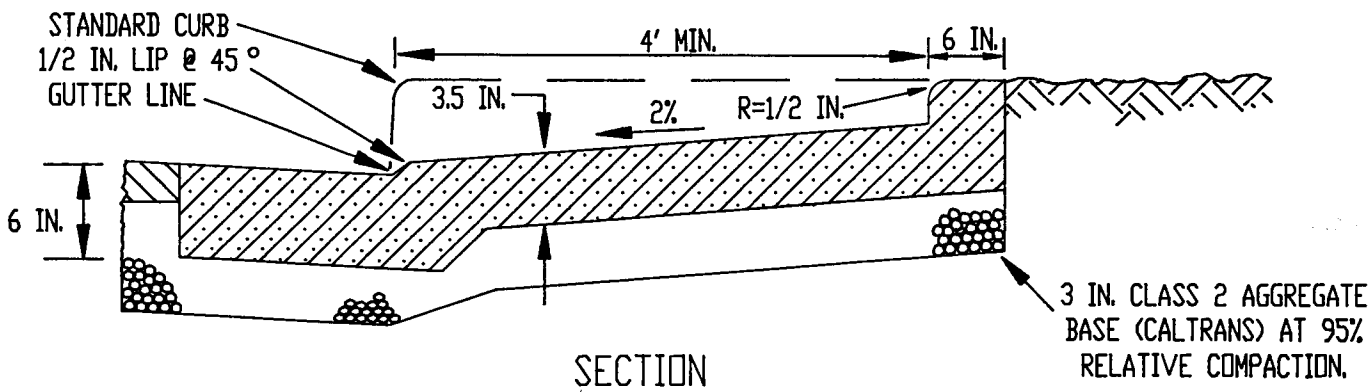

SECTION

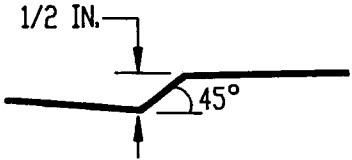

LIP DETAIL

CONCRETE SHALL BE: 2500 P.S.I., 520 LBS. CEMENT/CUBIC YARD, 4 IN. MAXIMUM SLUMP.

NOTE:  
SEE U.B.C. CHAPTER 2-71 FOR PLANTER AREA (10' WIDTH)

ST. SLOPE %	RAMP A	RAMP B
0 - 1	6.5	5
1 - 3	9	5
OVER 3	8	4



APPROVED BY: *Richard J. Cullen*  
DATE: 5/2/90  
PUBLIC SERVICES DIRECTOR R.C.E. 23797

CITY OF MARTINEZ  
STANDARD HANDICAP RAMP CASE B

SCALE: NONE  
STD. DRVG. NO. S-10B  
SHEET 2 OF 2

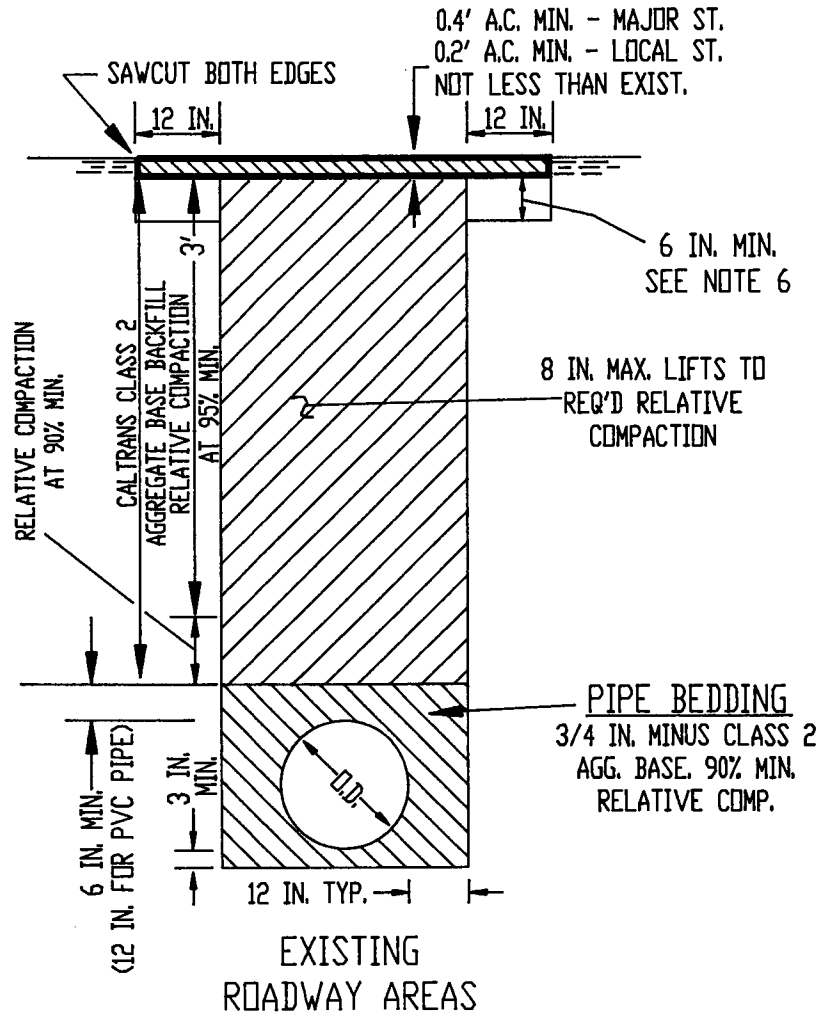

NOTES:

1. CITY INSPECTION REQUIRED PRIOR TO BACKFILL AND PRIOR TO ANY PAVEMENT PLACEMENT.
2. WHEN EDGE OF TRENCH IS PARALLEL AND WITHIN 3' OF EDGE OF PAVEMENT, EXISTING A.C. SECTION SHALL BE REMOVED AND REPLACED AS PART OF FINISH TRENCH PAVING. THIS APPLIES REGARDLESS OF WHAT MAY OR MAY NOT ABUT THE EDGE OF PAVEMENT.
3. EDGE OF TRENCH SHALL BE 4 IN. MINIMUM AWAY FROM LIP OF GUTTER.
4. COMPACTION OF BACKFILL BY JETTING IS NOT PERMITTED.
5. CONTRACTOR SHALL COMPLY WITH UTILITY AGENCY'S PIPE BEDDING REQUIREMENTS WHERE APPLICABLE.
6. BACKFILL SHALL BE EXTENDED TO INCLUDE THIS AREA, IF AGGREGATE BASE DOES NOT EXIST HERE.
7. PRIME COAT AND TACK COAT SHALL BE APPLIED TO COMPLETE WIDTH AND EDGES JUST PRIOR TO PLACING ASPHALT CONCRETE.



APPROVED BY: *Richard R. Cullen* DATE: *9/24/91*  
PUBLIC SERVICES DIRECTOR R.C.E. 23787

CITY OF MARTINEZ  
STANDARD TRENCH  
BACKFILL

SCALE: NONE  
STD. DRVG.  
NO.  
S-11A  
SHEET 1 OF 4



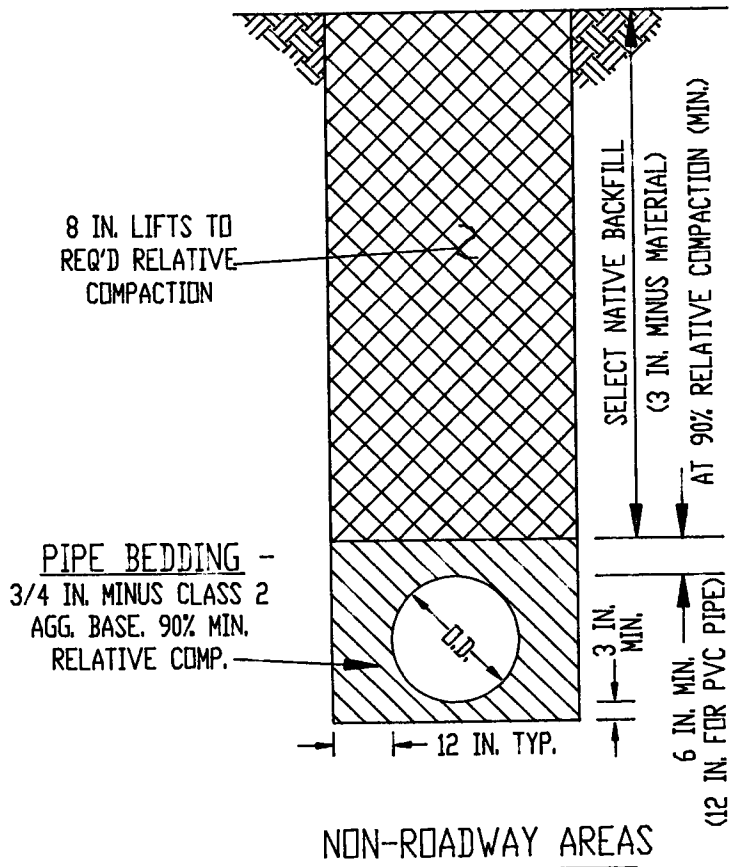

NOTES:

1. CITY INSPECTION REQUIRED TO PRIOR TO BACKFILL.
2. COMPACTION OF BACKFILL BY JETTING IS NOT PERMITTED
3. CONTRACTOR SHALL COMPLY WITH UTILITY AGENCY'S PIPE BEDDING REQUIREMENTS WHERE APPLICABLE.

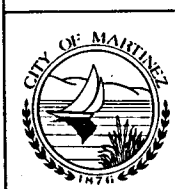

APPROVED BY:

DATE:

*Richard P. Cullen* 9/25/91  
PUBLIC SERVICES DIRECTOR R.C.E. 23797

CITY OF MARTINEZ

STANDARD TRENCH  
BACKFILL

SCALE: NONE

STD. DRVG.  
NO.

S-11B

SHEET 2 OF 4

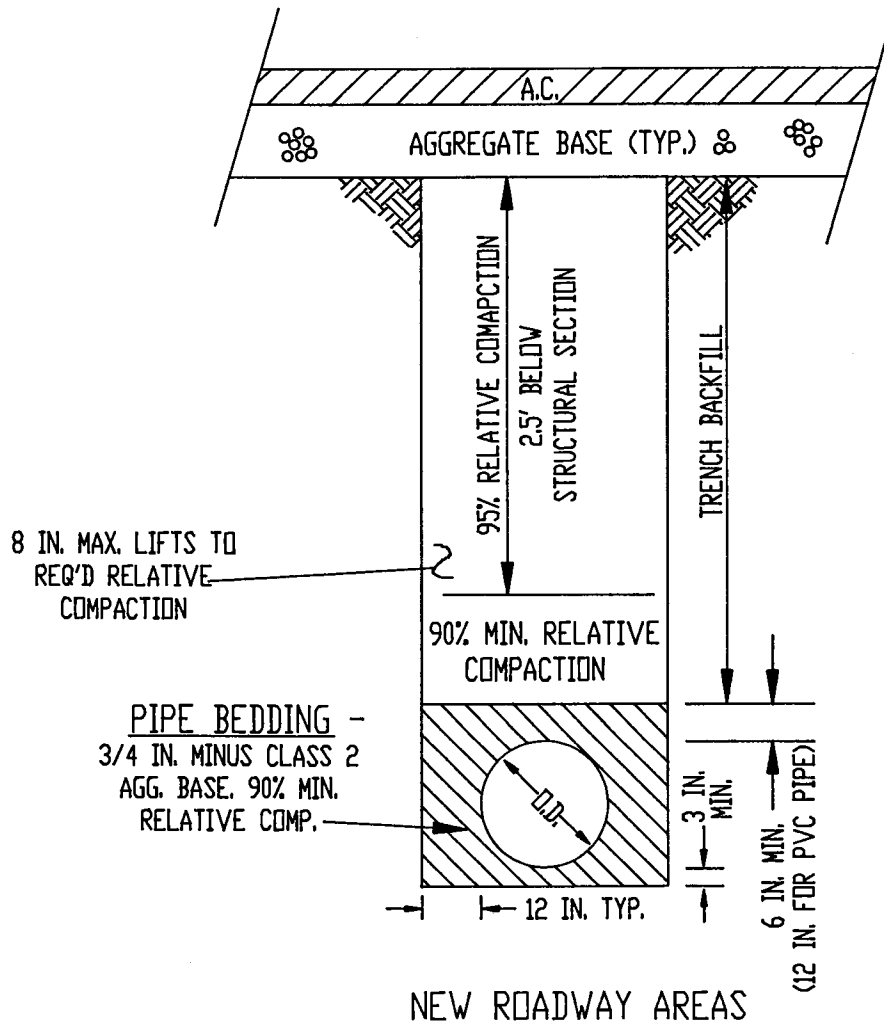

**NOTES:**

TRENCH BACKFILL IN NEW ROADWAY AREAS SHALL MEET THE FOLLOWING REQUIREMENTS:

1. FREE OF ORGANIC MATERIAL, STONES (ROCKS) OR LUMPS EXCEEDING 3 INCHES IN GREATEST DIMENSION.
2. SHALL HAVE A SAND EQUIVALENT OF 20 OR GREATER. CITY SHALL BE PROVIDED WITH TEST RESULTS PRIOR TO PLACEMENT.
3. SHALL HAVE A PLASTICITY INDEX OF 17 OR LESS. CITY SHALL BE PROVIDED WITH TEST RESULTS PRIOR TO PLACEMENT.
4. CITY INSPECTION REQUIRED PRIOR TO BACKFILL AND PRIOR TO ANY PAVEMENT PLACEMENT.
5. COMPACTION OF BACKFILL BY JETTING IS NOT PERMITTED.
6. CONTRACTOR SHALL COMPLY WITH UTILITY AGENCY'S PIPE BEDDING REQUIREMENTS WHERE APPLICABLE.



APPROVED BY: *Richard Cullen* DATE: *9/24/91*  
 PUBLIC SERVICES DIRECTOR R.C.E. 23797

CITY OF MARTINEZ

STANDARD TRENCH  
 BACKFILL

SCALE: NONE  
 STD. DRVG.  
 NO.  
 S-11C  
 SHEET 3 OF 4

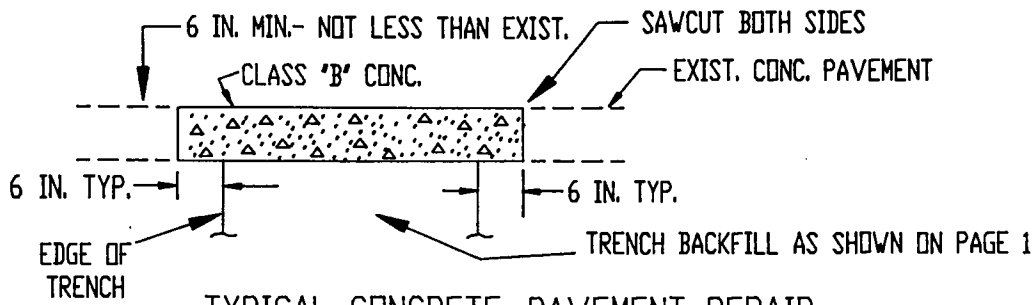

TYPICAL CONCRETE PAVEMENT REPAIR

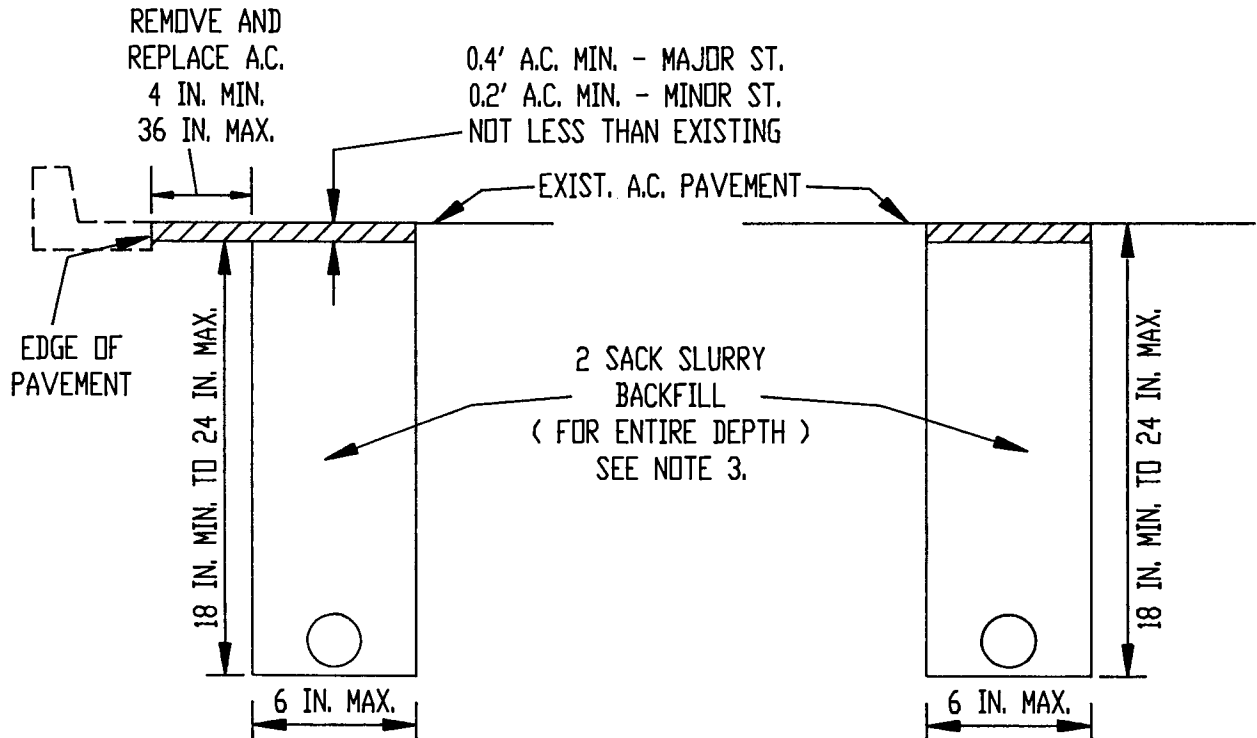

PARALLEL TO CURB

PERPENDICULAR CROSSING  
( REQUIRES PRIOR APPROVAL )

ROCKWHEEL TRENCH

NOTES:

1. CITY INSPECTION REQUIRED PRIOR TO BACKFILL AND PRIOR TO CONCRETE OR ASPHALT PLACEMENT.
2. WHEN EDGE OF TRENCH IS PARALLEL AND WITHIN 3' OF EDGE OF PAVEMENT, EXISTING A.C. SECTION SHALL BE REMOVED AND REPLACED AS PART OF FINISH TRENCH PAVING. THIS APPLIES REGARDLESS OF WHAT MAY OR MAY NOT ABUT THE EDGE OF PAVEMENT.
3. SLURRY CEMENT BACKFILL SHALL CONFORM TO SECTION 19-3.062 OF STATE (CALTRANS) STANDARD SPECIFICATIONS.
4. PRIME COAT AND TACK COAT SHALL BE APPLIED TO COMPLETE WIDTH AND EDGES JUST PRIOR TO PLACING ASPHALT CONCRETE.



APPROVED BY: *Richard R. Cullen* DATE: *9/24/97*  
PUBLIC SERVICES DIRECTOR R.C.E. 23797

CITY OF MARTINEZ  
STANDARD TRENCH  
BACKFILL

SCALE: NONE  
STD. DRWG.  
NO.  
S-11D  
SHEET 4 OF 4

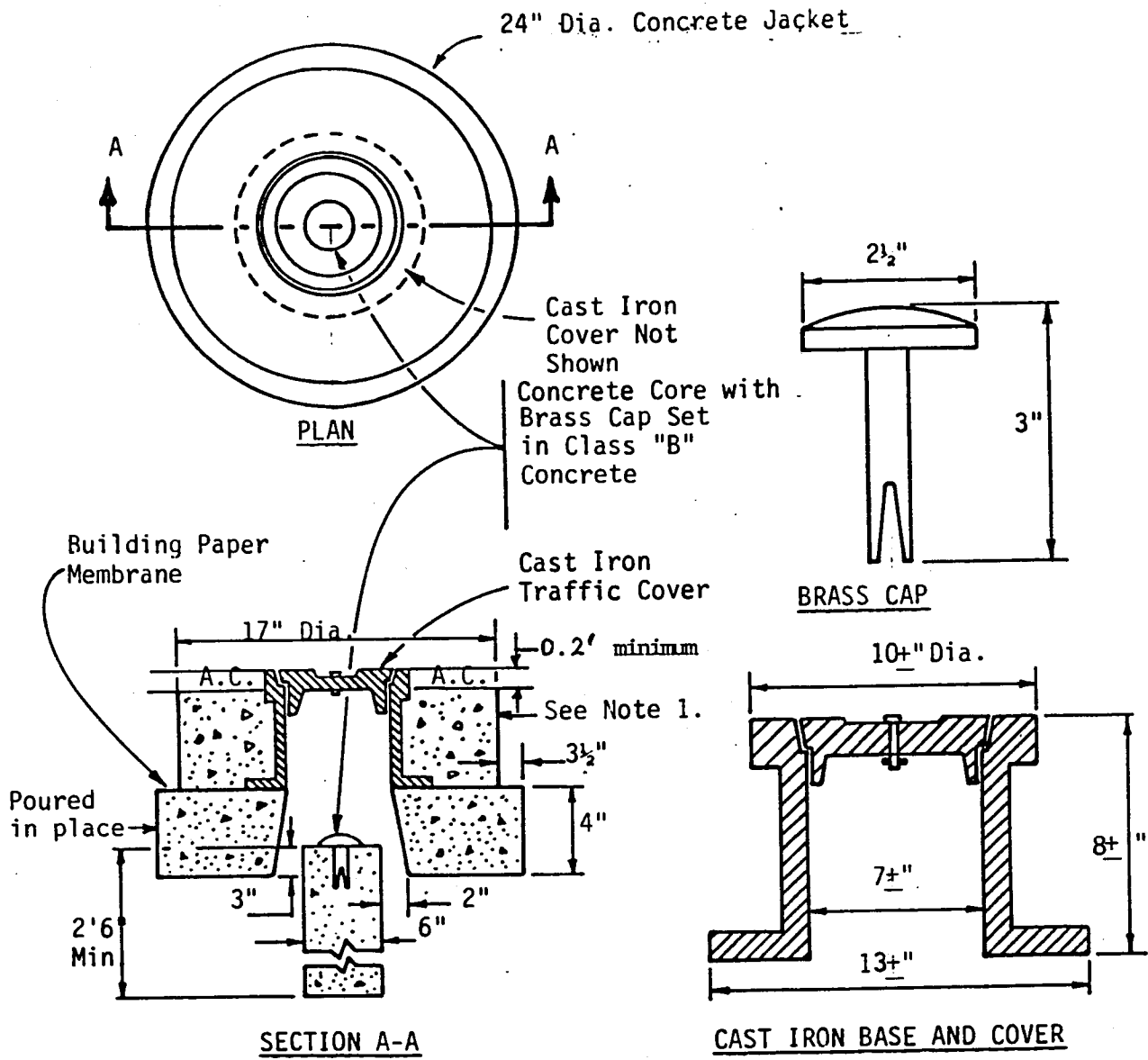

Notes:

1. Precast alternates may be accepted upon approval of City Engineer.
2. Cast iron cover shall have the words "City Monument" in raised letters, center punch holes in brass caps shall be placed by a licensed land surveyor or registered engineer. The No. of the engineer or surveyor shall be stamped on the cap.

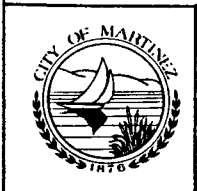

APPROVED BY: *Richard P. Cullen* DATE: 5/2/90  
 PUBLIC SERVICES DIRECTOR R.C.E. 23797

CITY OF MARTINEZ  
 SURVEY MONUMENT

SCALE: NONE  
 STD. DRWG. NO.  
 S-12  
 SHEET 1 OF 1

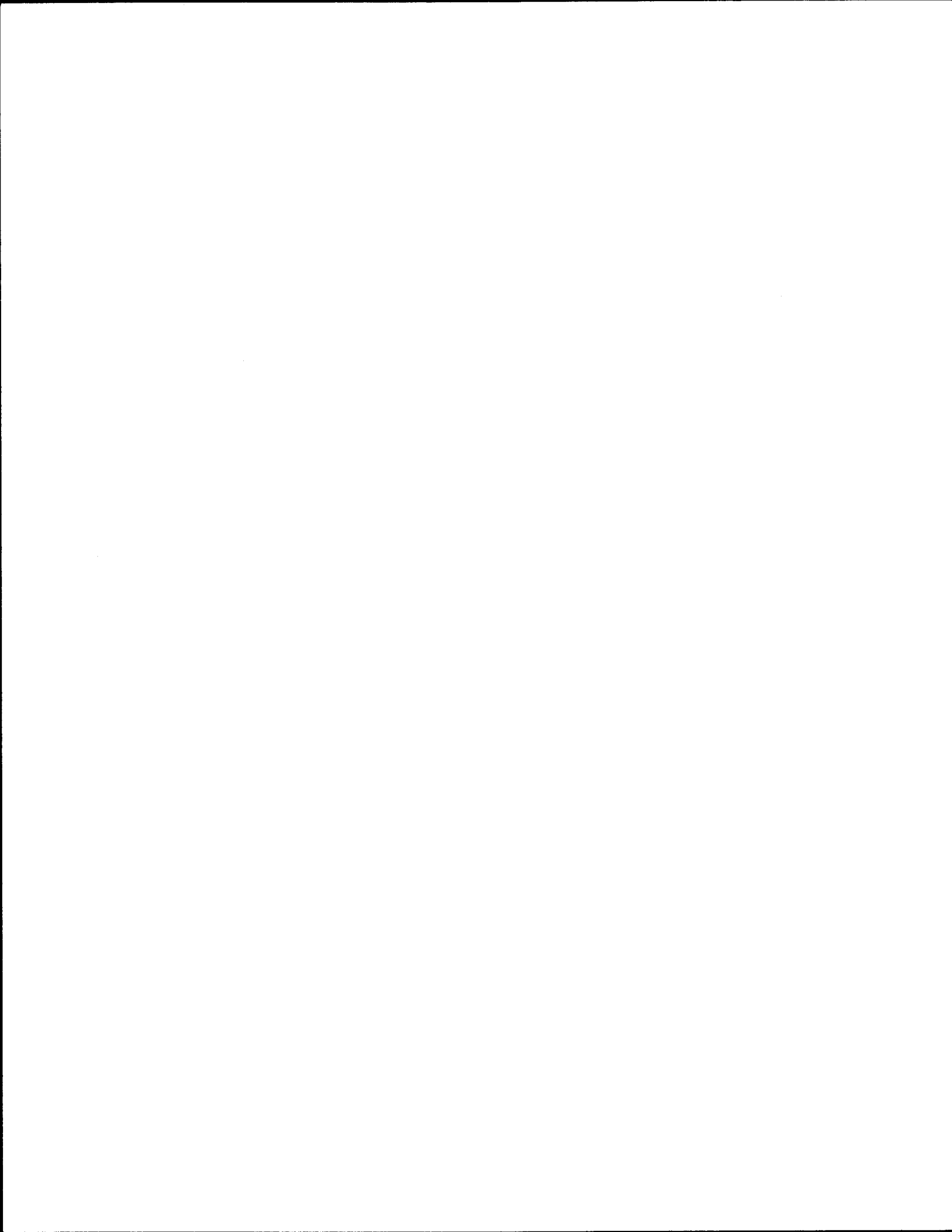

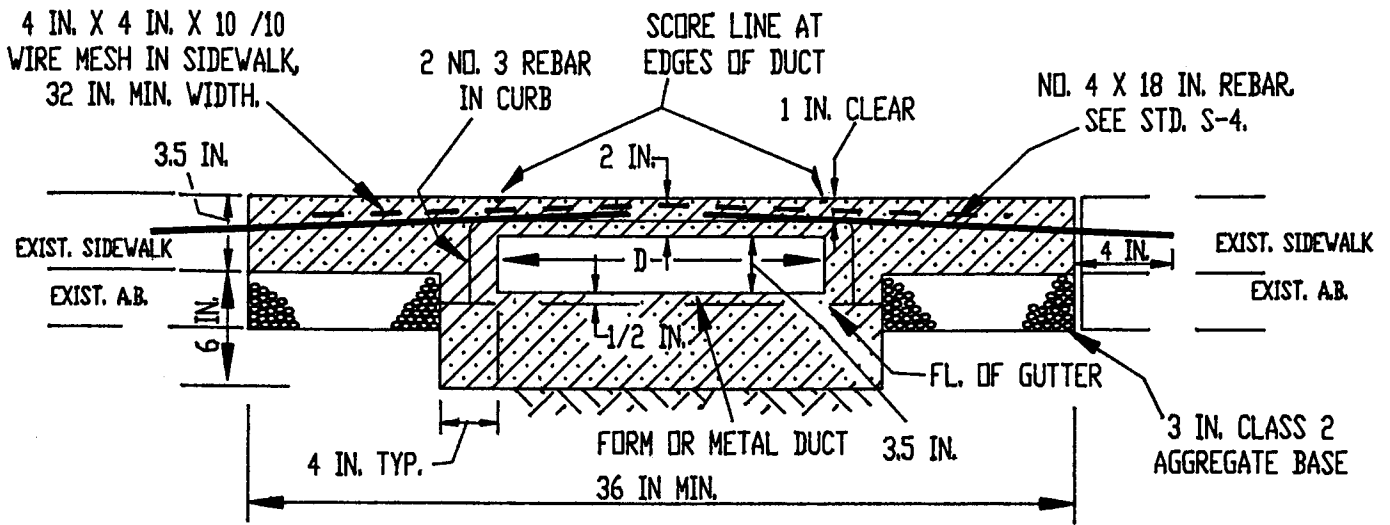

SECTION A-A

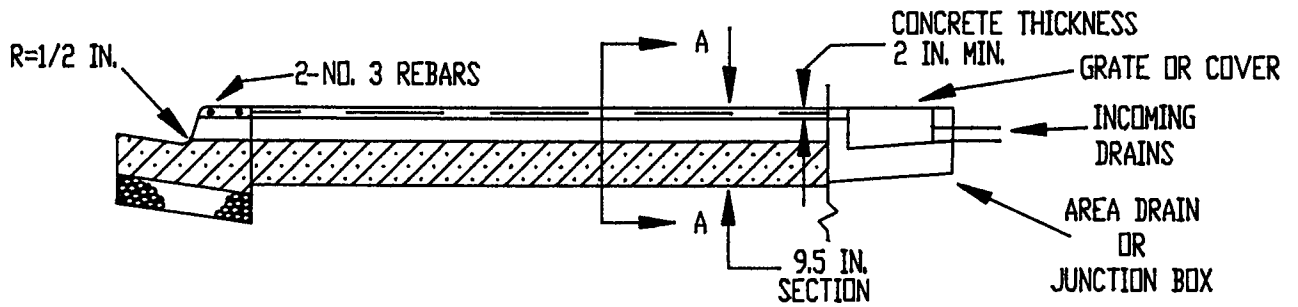

LONGITUDINAL SECTION

DIMENSION D	MAXIMUM CAPACITY
6 IN.	0.57 CUBIC FEET PER SEC.
9 IN.	0.94 CUBIC FEET PER SEC.
12 IN. MAX.	1.29 CUBIC FEET PER SEC.

NOTES:

- 18 GAUGE GALVANIZED METAL DUCT OR FORM SHALL BE SUPPORTED TO PREVENT DISTORTION DURING POURING OF CONCRETE.
- COLLAPSIBLE, REMOVABLE FORM MAY BE USED IN LIEU OF 18 GA. METAL DUCT.
- THE CONCRETE AND DUCT SHALL EXTEND CONTINUOUSLY FROM THE AREA DRAIN TO FACE OF CURB.
- CAPACITIES ARE BASED ON S=1/4 IN. PER 1' OR 2%.
- REFER TO STD. S-4 FOR JOINTS TO EXISTING CONCRETE.
- REFER TO STD. S-5 FOR CURB & GUTTER REPLACEMENT.



APPROVED BY: *Richard P. Cullen* DATE: 5/2/90  
 PUBLIC SERVICES DIRECTOR R.C.E. 23797

CITY OF MARTINEZ  
 SIDEWALK BOX  
 CROSS DRAINS -  
 EXIST. SIDEWALK

SCALE: NONE  
 STD. DRWG.  
 NO.  
 S-13A  
 SHEET 1 OF 2

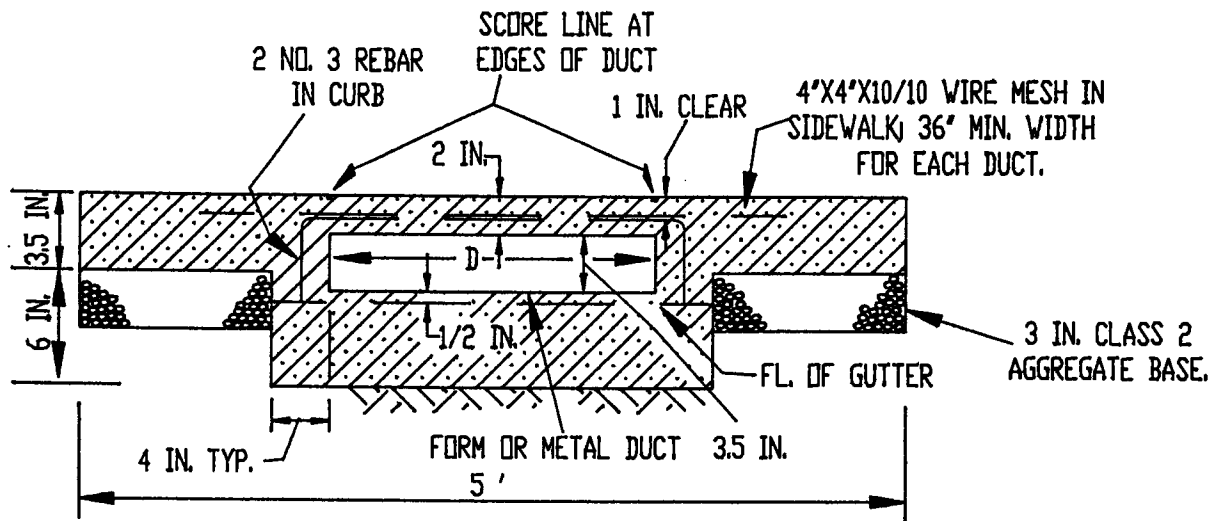

SECTION A-A

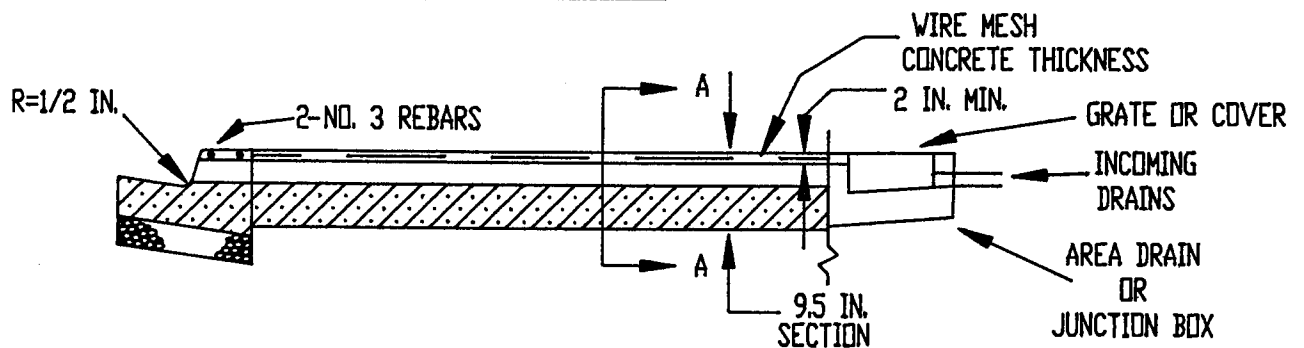

LONGITUDINAL SECTION

DIMENSION D	MAXIMUM CAPACITY
6 IN.	0.57 CUBIC FEET PER SEC.
9 IN.	0.94 CUBIC FEET PER SEC.
12 IN. MAX.	1.29 CUBIC FEET PER SEC.

NOTES:

1. 18 GAUGE GALVANIZED METAL DUCT OR FORM SHALL BE SUPPORTED TO PREVENT DISTORTION DURING POURING OF CONCRETE.
2. COLLAPSIBLE, REMOVABLE FORM MAY BE USED IN LIEU OF 18 GA. METAL DUCT.
3. THE CONCRETE AND DUCT SHALL EXTEND CONTINUOUSLY FROM THE AREA DRAIN TO FACE OF CURB.
4. CAPACITIES ARE BASED ON S=1/4 IN. PER 1' OR 2%.



APPROVED BY:

DATE: 5/2/90

*Richard R. Cullen*  
PUBLIC SERVICES DIRECTOR R.C.E. 23797

CITY OF MARTINEZ  
SIDEWALK BOX  
CROSS DRAINS--  
NEW INSTALLATION

SCALE: NONE  
STD. DRWG.  
NO.  
S-13A

SHEET 2 OF 2

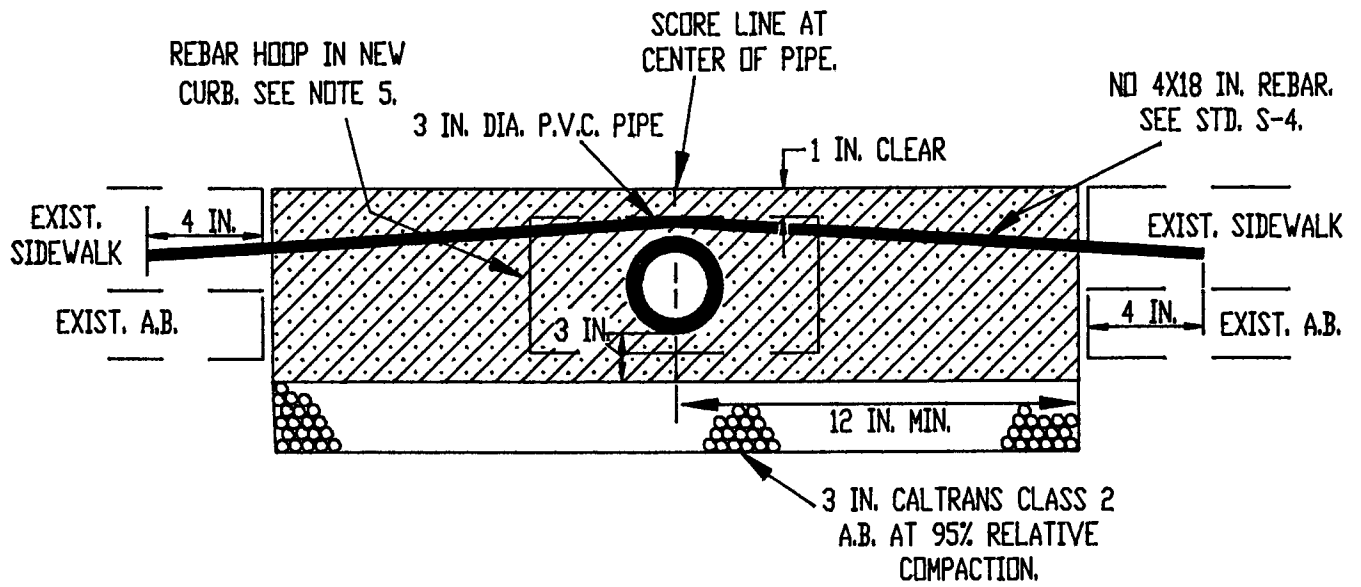

SECTION B-B

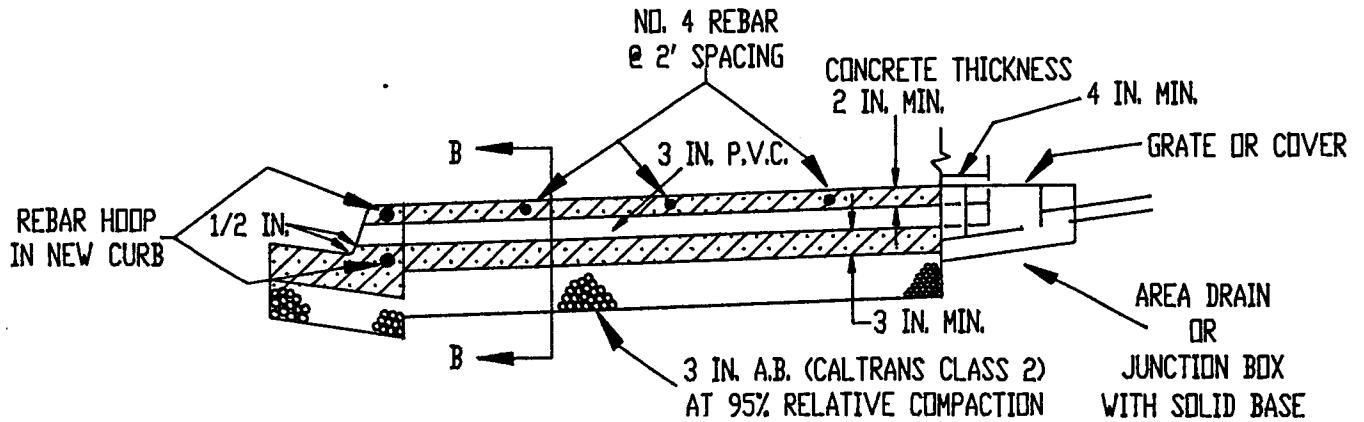

LONGITUDINAL SECTION

NOTES:

1. MAXIMUM CAPACITY = 0.15 CUBIC FEET PER SECOND AT S=1/4 IN. PER 1' OR 2%.
2. NO PIPE JOINTS SHALL BE ALLOWED. PIPE SHALL BE CONTINUOUS FROM FACE OF CURB TO AREA DRAIN.
3. P.V.C. SHALL CONFORM TO A.S.T.M. D3034 SCHEDULE 40.
4. INSTALLATION THRU EXISTING SIDEWALK REQUIRES 2' MINIMUM WIDTH CUT - OUT.
5. OPENING THRU CURB MAY BE CORE DRILLED WHEN APPROVED BY THE CITY.
6. ADDITIONAL PIPES MAY BE PLACED AT 4 IN. MINIMUM CLEARANCE BETWEEN PIPES.
7. REFER TO STD. S-4 FOR JOINTS TO EXISTING CONCRETE.
8. REFER TO STD. S-5 FOR CURB & GUTTER REPLACEMENT.



APPROVED BY:

DATE: 5/2/90

*Richard R. Cullen*  
PUBLIC SERVICES DIRECTOR R.C.E. 23797

CITY OF MARTINEZ

SIDEWALK  
PIPE CROSS DRAIN -  
EXISTING SIDEWALK

SCALE: NONE

STD. DRWG.

NL

S-13B

SHEET 1 OF 2



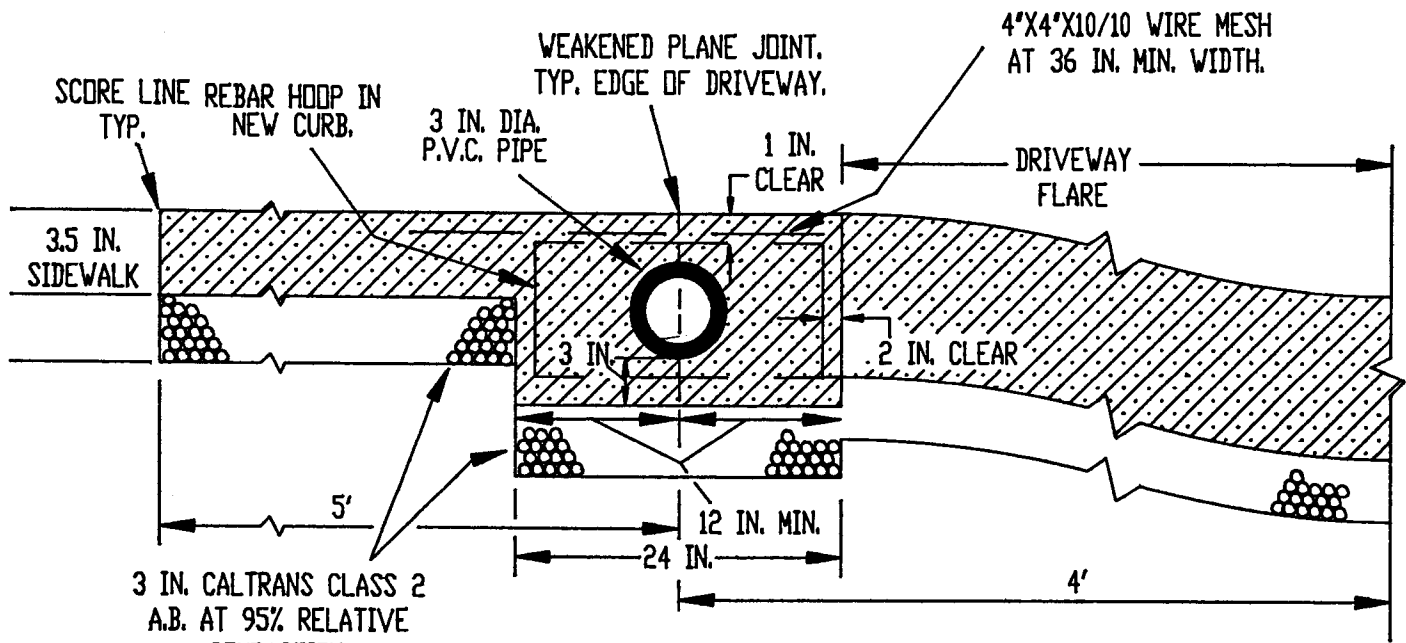

THICKENED SECTION CAN BE ANYWHERE WITHIN THE 5 FT. SECTION.  
**SECTION B-B**

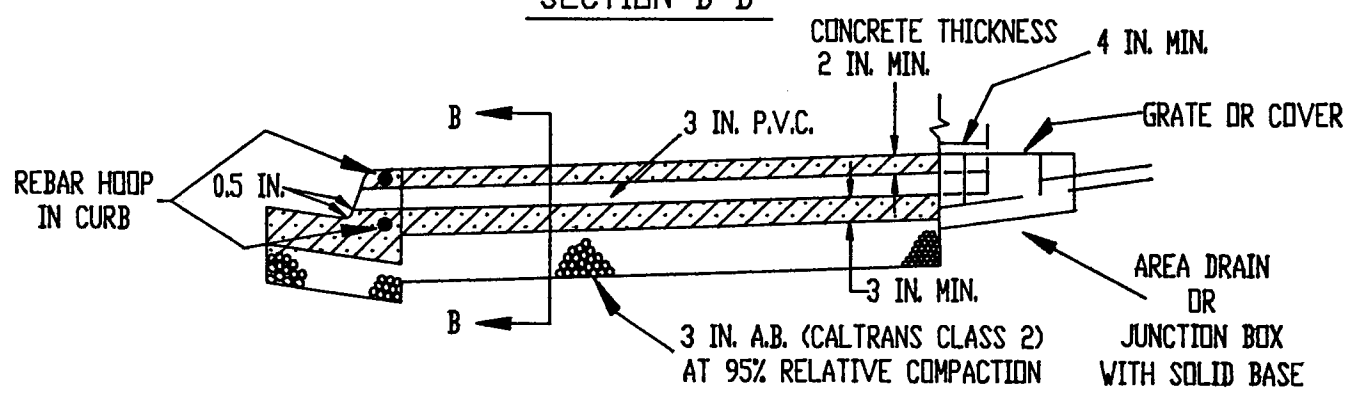

**LONGITUDINAL SECTION**

**NOTES:**

1. MAXIMUM CAPACITY = 0.15 CUBIC FEET PER SECOND AT S=1/4 IN. PER 1' OR 2%.
2. NO PIPE JOINTS SHALL BE ALLOWED. PIPE SHALL BE CONTINUOUS FROM FACE OF CURB TO AREA DRAIN.
3. P.V.C. SHALL CONFORM TO A.S.T.M. D3034 SCHEDULE 40.
4. ADDITIONAL PIPES MAY BE PLACED AT 4 INCHES MINIMUM CLEARANCE BETWEEN PIPES.
5. WHEN PIPE IS INSTALLED IN LOCATIONS OTHER THAN ADJACENT TO A DRIVEWAY, THE PIPE MAY BE LOCATED UNDER EITHER A WEAKENED PLANE JOINT OR A SCORE LINE.

	APPROVED BY: <i>Richard F. Cullen</i> DATE: 5/2/90 PUBLIC SERVICES DIRECTOR R.C.E. 23797	CITY OF MARTINEZ SIDEWALK PIPE CROSS DRAIN - NEW INSTALLATION	SCALE: NONE STD. DRWG. NO. <b>S-13B</b> SHEET 2 OF 2
	CITY OF MARTINEZ SIDEWALK PIPE CROSS DRAIN - NEW INSTALLATION		SCALE: NONE STD. DRWG. NO. <b>S-13B</b> SHEET 2 OF 2

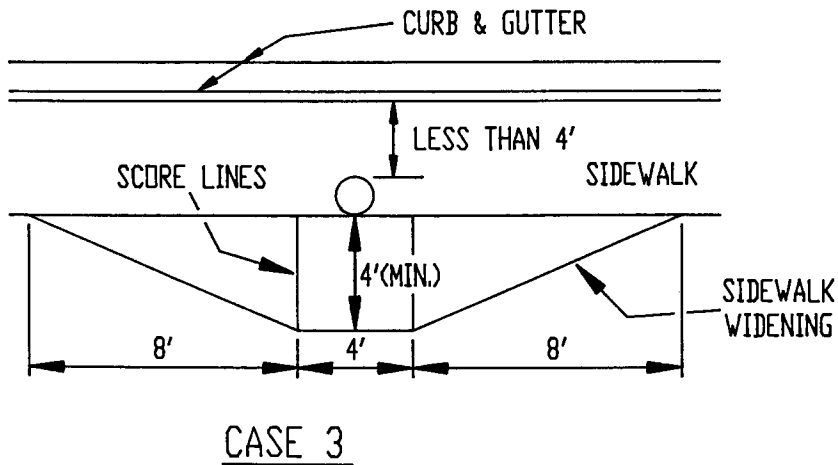
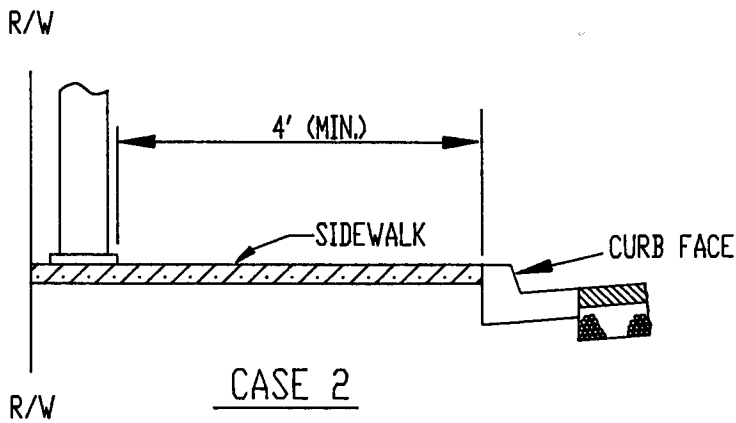
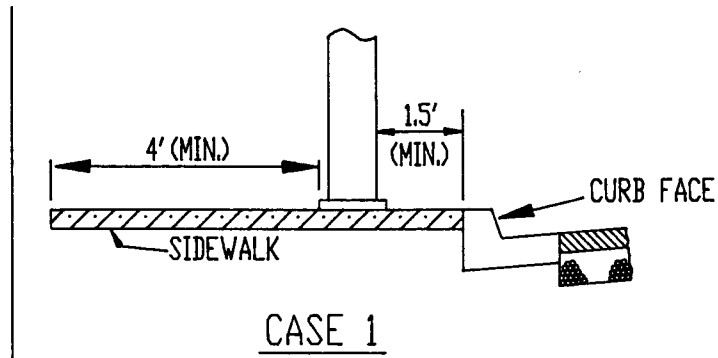

**NOTES:**

1. OBSTRUCTIONS WITHIN SIDEWALKS SHALL BE AVOIDED WHENEVER POSSIBLE.
2. THE MINIMUM CLEAR WIDTH OF SIDEWALK WILL BE FOUR (4) FEET FROM ANY VERTICAL OBSTRUCTION AS SHOWN ABOVE, WITH TOTAL MINIMUM SIDEWALK WIDTH OF 5 FEET (SEE NOTE 5 ON STD. DWG. S-3).
3. THE DISTANCE FROM THE CURB FACE TO A FIRE HYDRANT OR TRAFFIC SIGN SHALL IN NO INSTANCE BE GREATER THAN SIX (6) FEET.



APPROVED BY: *Richard K. Cullen* DATE: 5/2/90  
 PUBLIC SERVICES DIRECTOR R.C.E. 23797

CITY OF MARTINEZ  
 PARKWAY  
 OBSTRUCTION

SCALE: NONE  
 STD. DRWG.  
 NO.  
 S-14  
 SHEET 1 OF 1

# CUL-DE-SACS

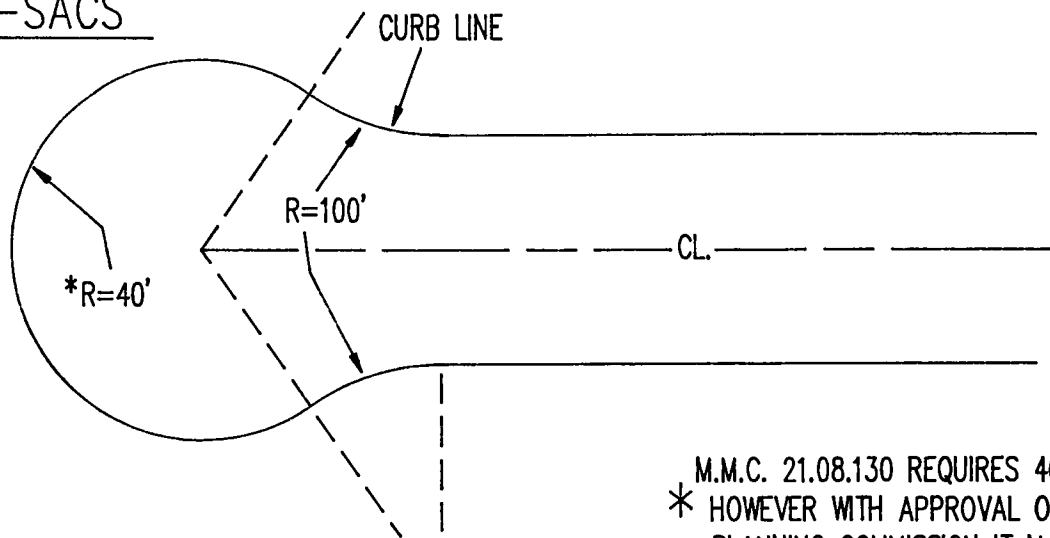

M.M.C. 21.08.130 REQUIRES 40' RADIUS,  
 \* HOWEVER WITH APPROVAL OF THE  
 PLANNING COMMISSION IT MAY BE  
 REDUCED TO A 36' RADIUS WITH  
 "NO PARKING" RESTRICTIONS.

# TURNAROUNDS

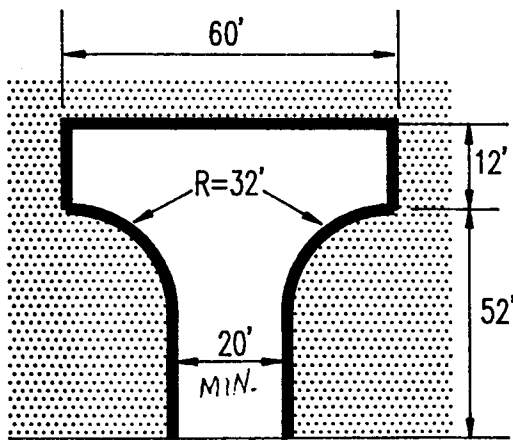

T-TURN  
NO SCALE

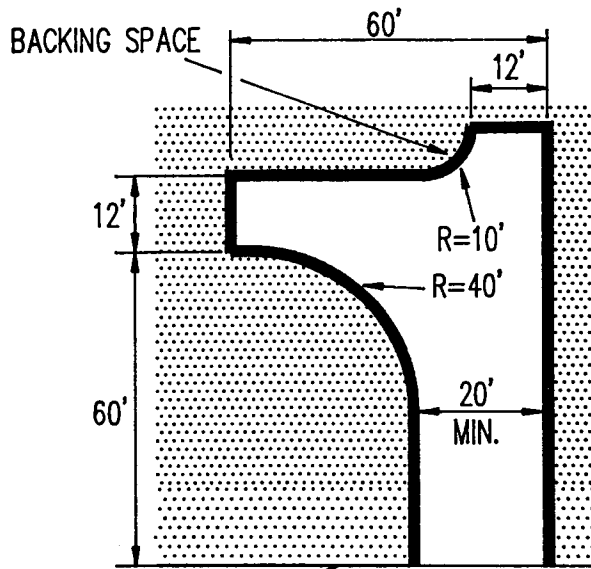

SHUNT  
NO SCALE

NOTES:

1. TURNAROUNDS ( HAMMERHEADS ) ARE PERMITTED ONLY ON PRIVATE DRIVES SERVING FOUR OR LESS HOMES UNLESS OTHERWISE APPROVED BY THE CITY.
2. TURNAROUNDS ARE NOT PERMITTED ON PUBLIC STREETS.
3. "NO PARKING ANYTIME" RESTRICTIONS ARE REQUIRED FOR ENTIRE TURNAROUND AREA.

APPROVED BY: <i>Richard P. Cullen</i> DATE: <i>2/27/92</i> PUBLIC SERVICES DIRECTOR R.C.E. 23797	CITY OF MARTINEZ	SCALE: NONE
	CUL-DE-SAC & TURNAROUND STANDARDS	STD. DRWG. NO. S-15
		SHEET 1 OF 1

APPROVED *May 15, 1972*  
 PUBLIC WORKS DIRECTOR - R. E. CERT. NO. 16870

**NOTES**

1. GRADE DIFFERENCE BETWEEN INTERSECTING STREET CROSS SLOPE AND CENTERLINE OF PROPOSED DRIVEWAY IS TO BE NO GREATER THAN 10% FOR 10 FEET STARTING FROM FACE OF CURB ON EDGE OF DRIVEWAY. IN NO CASE SHALL GRADE FROM FACE OF CURB OR EDGE OF DRIVEWAY BE GREATER THAN 10% WITHIN THE FIRST 10'. IF DRIVEWAY IS MORE THAN ONE LOT, MAX. DRIVEWAY GRADE IS 20% IF DRIVEWAY IS MORE THAN ONE LOT, A 25% MAX. GRADE WILL BE ALLOWED ADDITIONALLY ONLY WITH MUST BE PROVIDED TO ACCOMMODATE THE EXCESS GRADE BREAK.
2. CAR DIMENSIONS WERE OBTAINED FROM THE 1977 EDITION OF "PARKING DIMENSIONS", MOTOR VEHICLE MANUFACTURES ASSOC. 320 NEW CENTER BLDG., DETROIT, MICH. 48202. THIS DESIGN & CONSTRUCTION AID IS BASED ON THE MOST UNFAVORABLE DIMENSIONS OF CARS LISTED FOR UNIQUE OR OVERSIZED CARS, A SPECIAL DESIGN IS REQUIRED.
3. "N" DENOTES DIFFERENCE IN ELEVATION BETWEEN REFERENCE LINE AND DRIVEWAY PLANE AT VARIOUS POINTS.
4. "L" VARYING LENGTH OF DRIVEWAY.

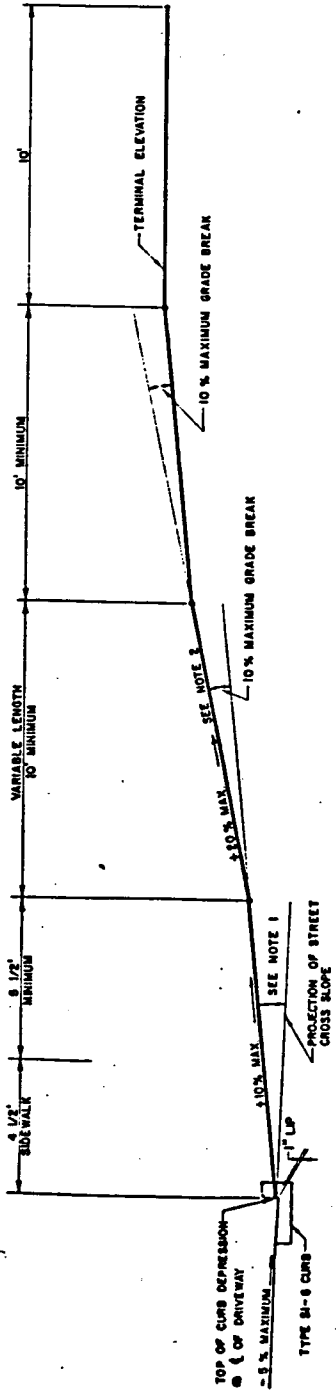

**DESCENDING DRIVEWAY**

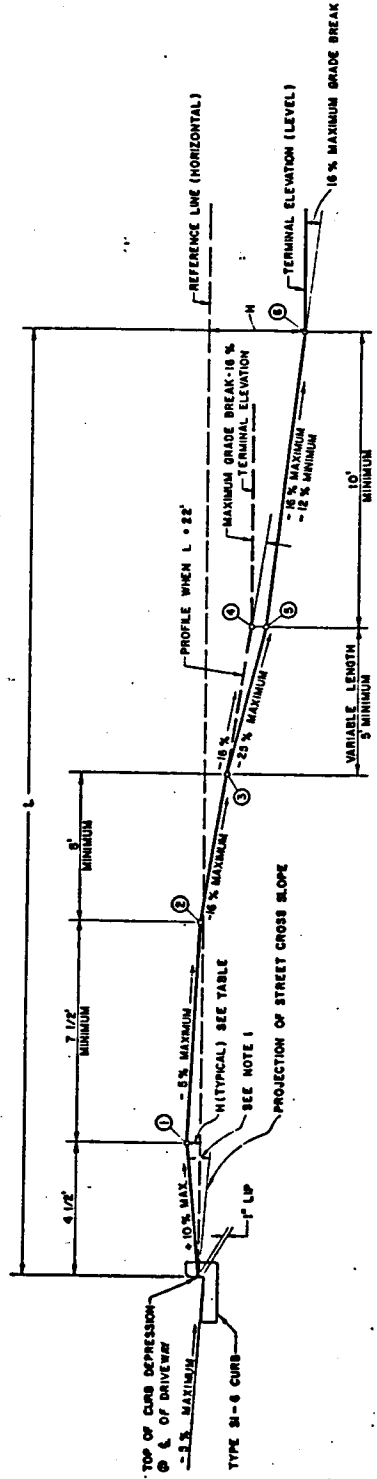

**TABLE OF OFFSETS "N" FROM REFERENCE LINE**

POINT	L+22	L+32	L+35	L+40	L+45
1	N+0.5	N+0.5	N+0.5	N+0.5	N+0.5
2	N+0.1	N+0.1	N+0.1	N+0.1	N+0.1
3	N+0.7	N+0.7	N+0.7	N+0.7	N+0.7
4	N+1.5	N+1.5	N+1.5	N+1.5	N+1.5
5	N+2.0	N+2.7	N+2.7	N+4.0	N+8.2
6	N+3.2	N+3.8	N+3.8	N+8.2	N+8.4



RIGHT SIDE OF ROAD

MEDIAN ISLAND

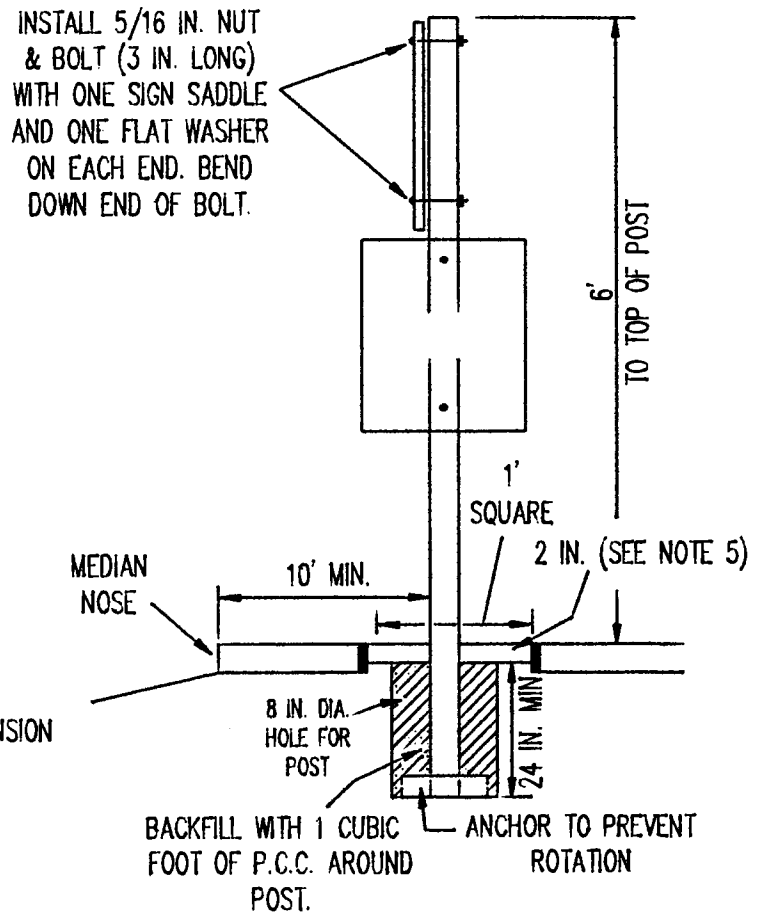
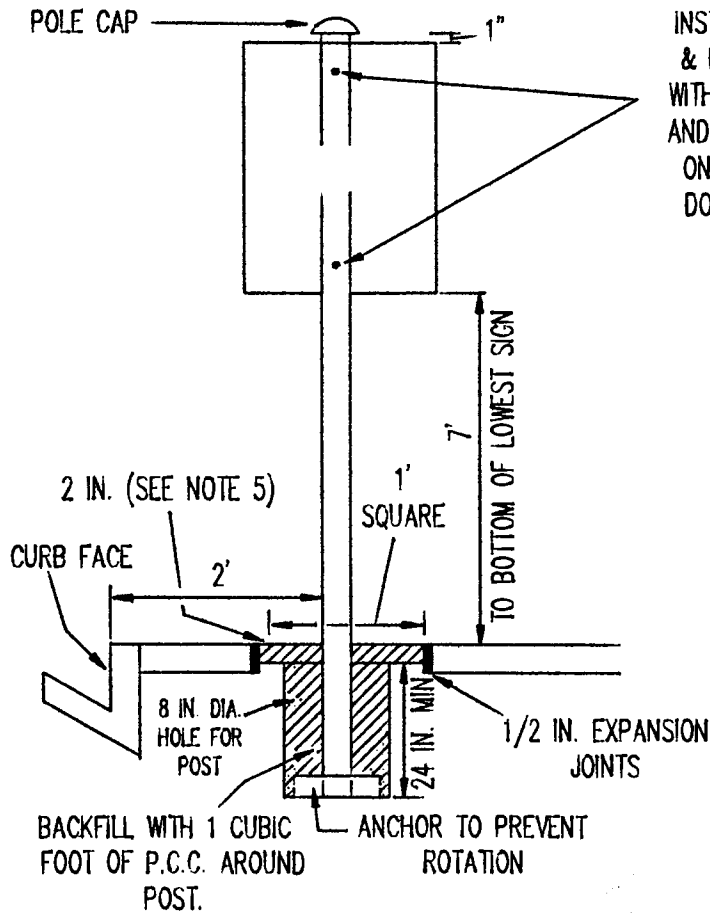

INSTALL 5/16 IN. NUT & BOLT (3 IN. LONG) WITH ONE SIGN SADDLE AND ONE FLAT WASHER ON EACH END. BEND DOWN END OF BOLT.

- NOTES:
1. ALL SIGNS SHALL BE REFLECTORIZED 0.080 GAUGE ALUMINUM AND CONFORM TO CALTRANS SPECIFICATIONS.
  2. SIGN POSTS SHALL BE 2-3/8 IN. O.D. GALVANIZED IRON PIPE. SIGNS 36 IN. OR LARGER & MEDIAN SIGNS SHALL HAVE 4 IN. X 4 IN. REDWOOD POSTS.
  3. SIGNS SHALL BE MOUNTED ON POSTS WITH SIGN SADDLES AND BOLTS DRILLED INTO POSTS. FOR SIGNS 36 IN. OR LARGER A GALVANIZED BACK BRACE IS REQUIRED.
  4. ALWAYS MOUNT WIDER SIGNS HIGHEST ON THE POST.
  5. FOR POSTS INSTALLED WITHIN EXISTING CONCRETE, SAWCUT AND REMOVE 1 FT. SQUARE OR CORE DRILL 8 IN. DIA. AND REPLACE WITH 2 IN. P.C.C. AS SHOWN IN DETAIL. P.C.C. BACKFILL SHALL ALWAYS BE 2 IN. BELOW ADJACENT FINISHED SURFACE.
  6. POSTS WITHIN SIDEWALK MUST MAINTAIN A 4' MIN. HORIZONTAL CLEARANCE FOR PEDESTRIANS. IF WALK IS 5' OR LESS WIDE NEXT TO CURB, SIGN POSTS SHALL BE INSTALLED 2 IN. BEHIND WALK BUT NO FURTHER THAN 6' FROM CURBFACE.
  7. FINAL LOCATION OF ALL SIGNS ARE SUBJECT TO APPROVAL OF THE CITY TRAFFIC ENGINEER.
  8. ALL STOP SIGNS AND WARNING SIGNS ARE 30 IN. X 30 IN. UNLESS OTHERWISE APPROVED. WARNING SIGNS ARE NORMALLY LOCATED 250' IN ADVANCE OF OBJECT.
  9. ALL "NO PARKING" SIGNS ARE 12 IN. X 18 IN. AND TYPICALLY SPACED AT 200' INTERVALS.
  10. ALL SIGNS SHALL BE IN CONFORMANCE WITH UNIFORM MANUAL OF TRAFFIC CONTROL DEVICES AND CALTRANS TRAFFIC MANUAL.
  11. LOCATE ALL UNDERGROUND UTILITIES PRIOR TO EXCAVATING POST HOLES.



APPROVED BY: *Richard R. Cullen*  
 DATE: 5/30/90  
 PUBLIC SERVICES DIRECTOR R.C.E. 23797

CITY OF MARTINEZ  
 STREET SIGNS

SCALE: NONE  
 STD. DRWG. NO. T-1  
 SHEET 1 OF 1

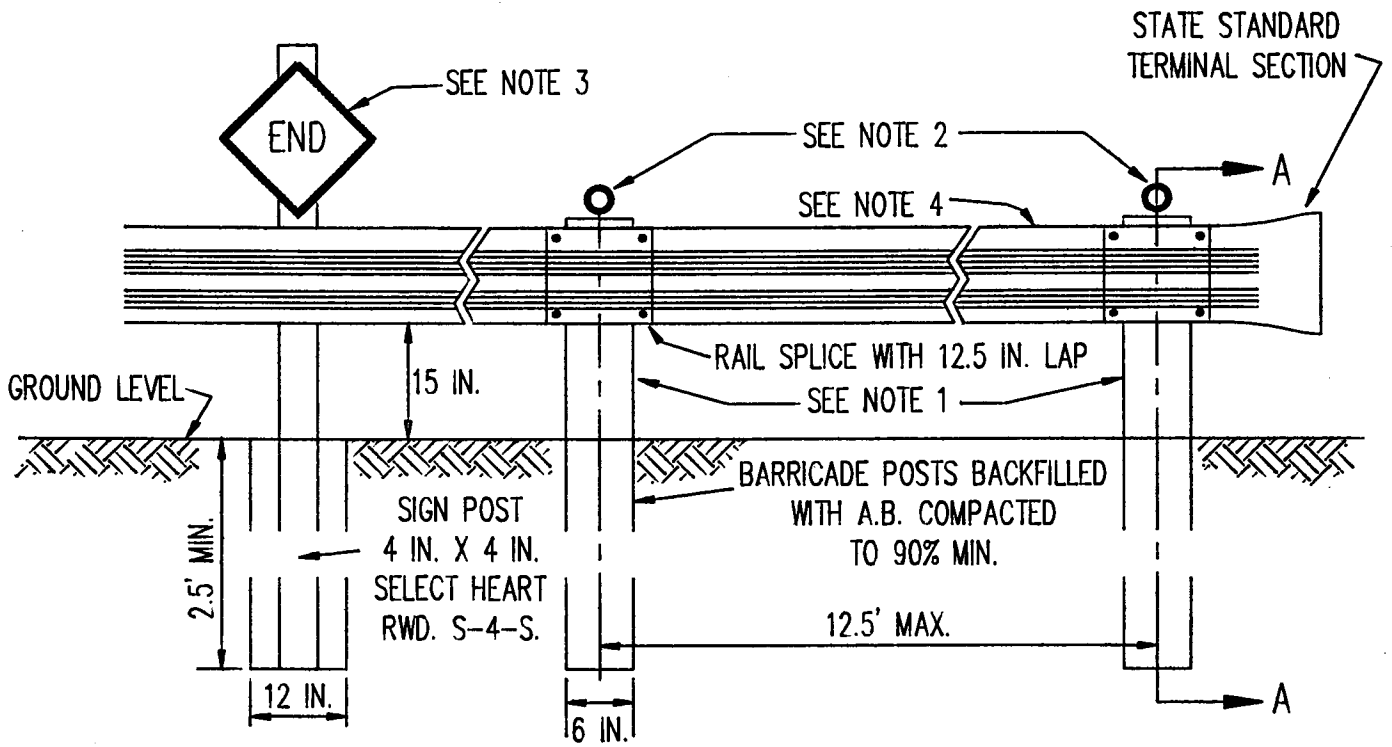

5/8 IN. GALVANIZED CARRIAGE BOLT WITH HEX NUT AND WASHER.

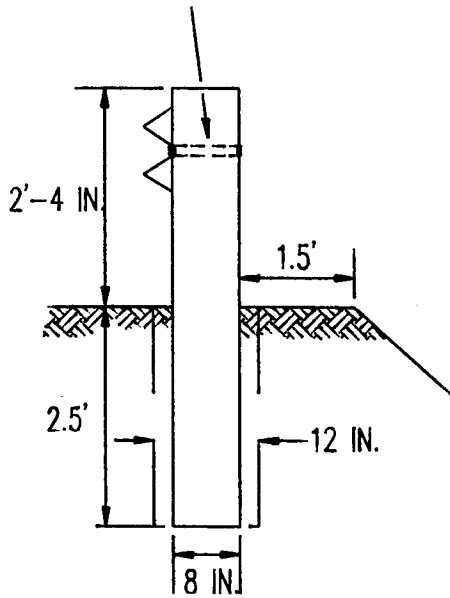

SECTION A-A

NOTES:

1. BARRICADE POSTS SHALL BE 6 IN. X 8 IN. S-4-S DENSE STRUCTURAL REDWOOD.
2. A 3 IN. CENTER MOUNT AMBER ACRYLIC PLASTIC REFLECTOR IN AN ALUMINUM BEZEL HOUSING SHALL BE INSTALLED ON EACH POST FACING TRAFFIC.
3. FOR DEAD-END STREETS AN .08 IN. THICK 24 IN. X 24 IN. W31R YELLOW DIAMOND "END" SIGN USING REFLECTING SHEETING SHALL BE MOUNTED WITH THE BOTTOM OF THE SIGN 4' ABOVE GROUND LEVEL AND LOCATED AS APPROVED BY THE CITY. USE 5/16 IN. GALVANIZED CARRIAGE BOLTS.
4. METAL GUARDRAIL, AASHO DESIG. M180, 12 GA. GALVANIZED STEEL.
5. A .08 IN. THICK 18 IN. X 18 IN. TYPE N SIGN WITH REFLECTIVE SHEETING SHALL BE MOUNTED AT 25' INTERVALS ALONG ENTIRE LENGTH OF BARRICADE WITH BOTTOM OF SIGN 4' ABOVE GROUND LEVEL. USE RED SIGNS FOR DEAD-END STREETS AND YELLOW SIGNS FOR OTHER LOCATIONS.



APPROVED BY:

DATE: 5/30/90

*Richard P. Cullen*  
PUBLIC SERVICES DIRECTOR R.C.E. 23797

CITY OF MARTINEZ

STREET BARRICADE

SCALE: NONE  
STD. DRWG.

NO.

T-2

SHEET 1 OF 1

NOTES:

1. ALL LOGS TO BE PRESSURE TREATED DOUGLAS FIR, 12 IN. DIA.
2. ALL POSTS TO BE PRESSURE TREATED ROUGH DOUGLAS FIR, #2 OR BETTER.
3. ALL TIES TO BE ROUGH DOUGLAS FIR, #2 OR BETTER.
4. PIPE STAKES TO BE SCHEDULE 40 GALVANIZED STEEL PIPES.
5. FASTEN 2 IN. X 8 IN. TIES TO ENDS OF LOGS AND FACES OF POSTS WITH GALVANIZED LAG SCREWS. INSTALL TWO (2) LAG SCREWS AT EACH END.
6. STAIN ALL EXPOSED SURFACES OF POSTS AND TIES WITH OLYMPIC #711 SEMI-TRANSPARENT STAIN.
7. LOCATE ALL UNDERGROUND UTILITIES PRIOR TO EXCAVATING POST HOLES.
8. BICYCLE ACCESS AND HORSE ACCESS SHALL BE CONSTRUCTED SEPERATELY OR IN COMBINATION AS APPROVED BY THE CITY.

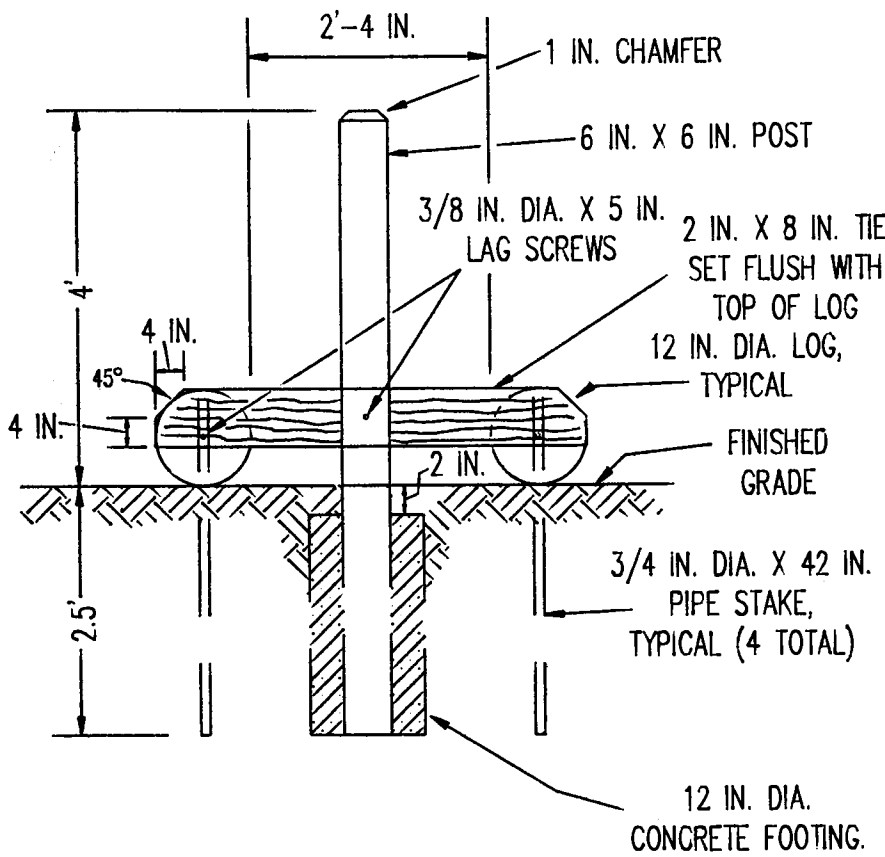

SIDE ELEVATION  
NO SCALE

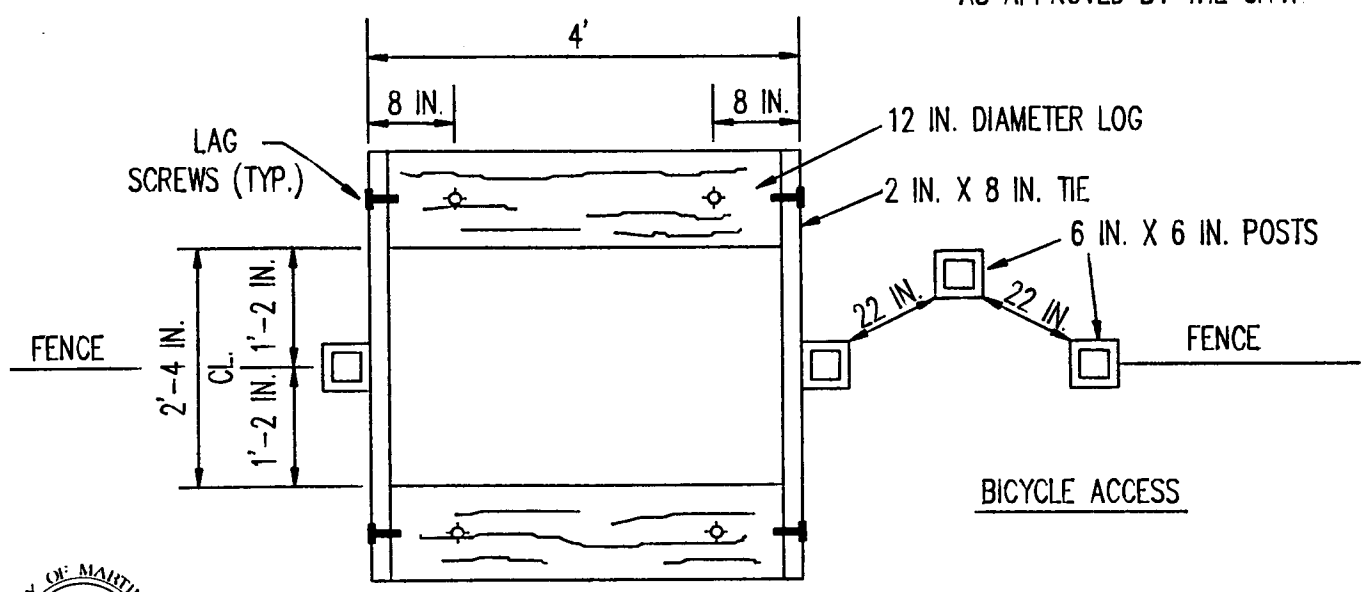

HORSE ACCESS

BICYCLE ACCESS

PLAN  
NO SCALE



MODIFICATION OF E.B.R.P.D. STD. DWG. R-7	APPROVED BY: <i>Richard R. Cullen</i> PUBLIC SERVICES DIRECTOR R.C.E. 23797	DATE: 5/30/90	CITY OF MARTINEZ	SCALE: NONE STD. DRWG. NO.
	MOTORCYCLE BARRIER			T-3 SHEET 1 OF 1



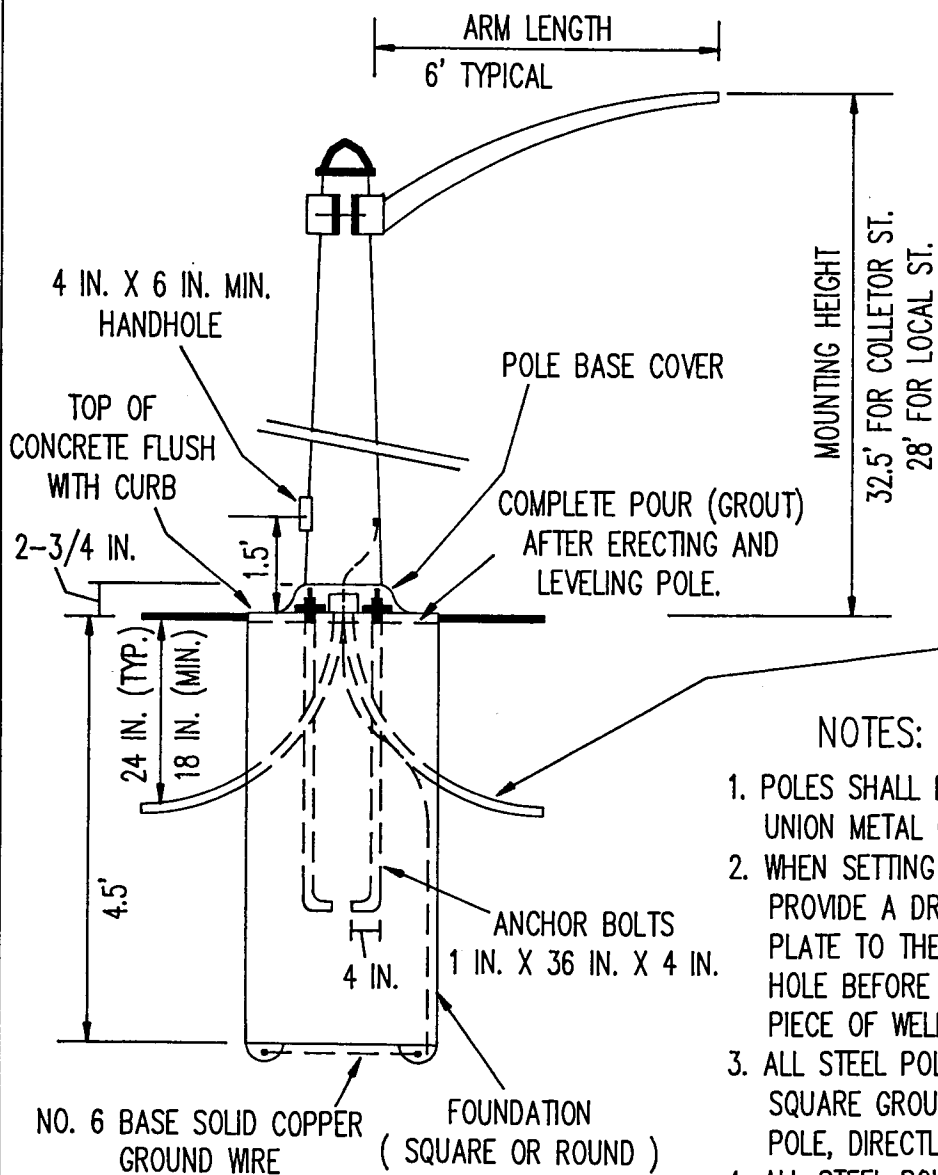

1.5 IN. MIN. DIA. 18 IN. RADIUS  
PLASTIC CONDUIT BEND, TYPE  
A.B.S., OR P.V.C. SCHEDULE 40

NOTES:

1. POLES SHALL BE GALVANIZED STEEL, AMERON, UNION METAL OR APPROVED EQUAL.
2. WHEN SETTING POLES WITH FLAT STEEL BASES, PROVIDE A DRAINAGE HOLE UNDER THE STEEL PLATE TO THE CENTER OF THE POLE. FORM HOLE BEFORE CONCRETE SETS USING A PIECE OF WELDING ROD OR EQUIVALENT.
3. ALL STEEL POLES TO HAVE 1/2 IN. 13 NC SQUARE GROUNDING NUT OR HOLDER IN THE POLE, DIRECTLY OPPOSITE THE HANDHOLE.
4. ALL STEEL POLES TO BE FURNISHED WITH POLE BASE COVERS, HANDHOLE AND HANDHOLE COVER.
5. ALL POLES SHALL BE IN ACCORDANCE WITH APPLICABLE REQUIREMENTS OF EE1-NEMA STANDARDS FOR STREET LIGHTING POLES, EE1 PUBLICATION NO. TDJ-135.
6. ANCHOR BOLTS TO BE COMPLETELY HOT-DIP GALVANIZED, PER ASTM SPEC. A153 AND BE FURNISHED WITH 6 IN. MINIMUM THREAD LENGTH.
7. A NO. 3-1/2 CALTRANS STD. SPLICE BOX SHALL BE FURNISHED WITH EACH STREET LIGHT AND AT MAXIMUM 200' INTERVALS.
8. ENTIRE SYSTEM SHALL ALSO MEET P.G. & E. STANDARDS. IN CASE OF CONFLICT, THE MORE STRICT STANDARD SHALL APPLY. THE APPLICABLE P.G. & E. RATE SCHEDULE IS LS-2C.

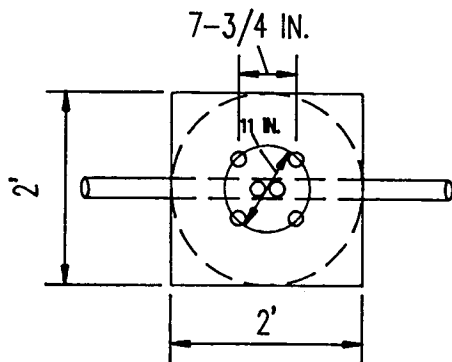

APPROVED BY:

DATE:

6/20/90

*Richard K. Cullen*  
PUBLIC SERVICES DIRECTOR R.C.E. 23797

CITY OF MARTINEZ

STREET  
LIGHTING POLES

SCALE: NONE  
STD. DRWG.

NO.

T-4

SHEET 1 OF 1

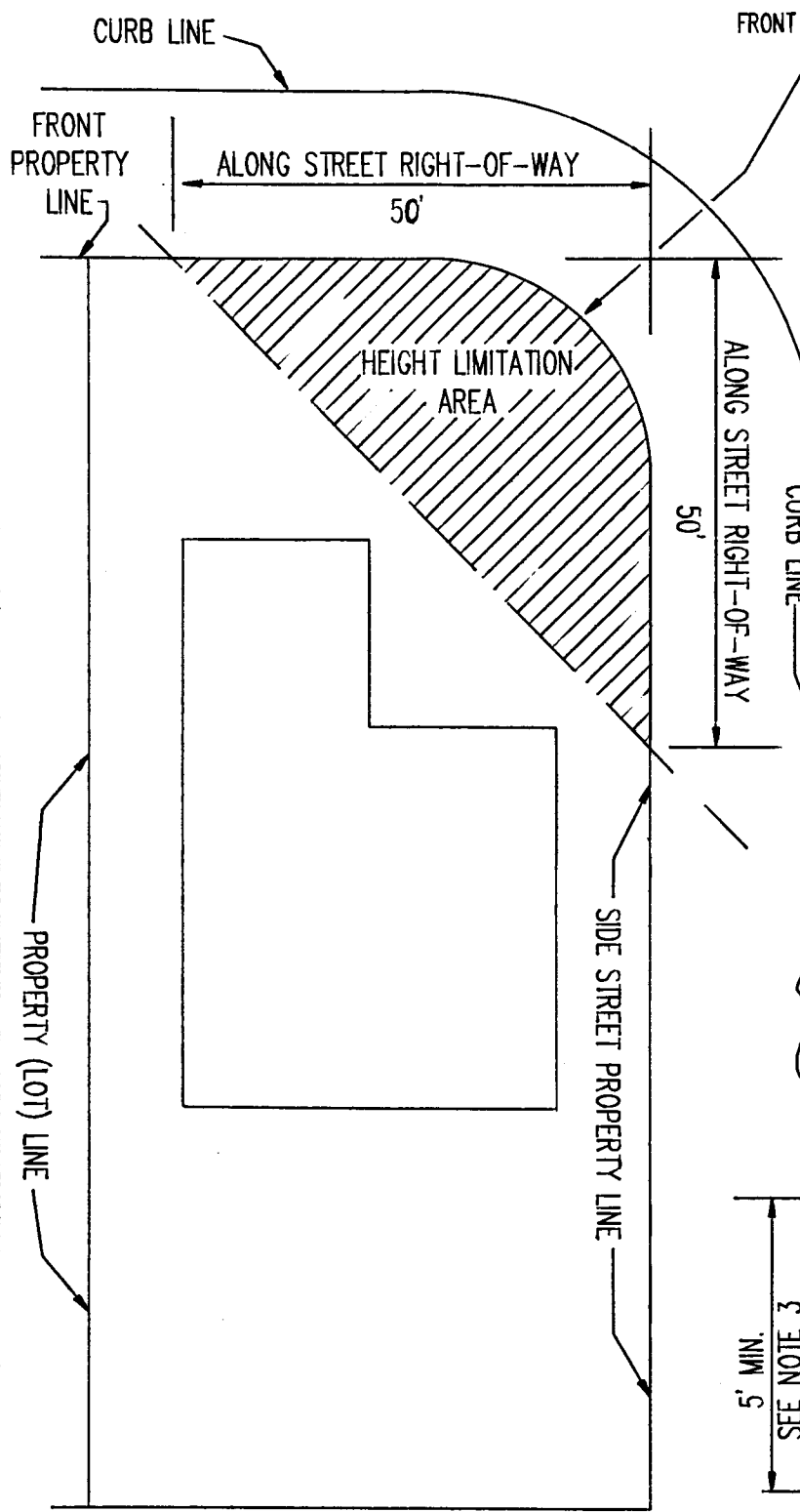

**NOTES:**

1. ALL FENCES, WALLS, HEDGES, AND OTHER OBSTRUCTIONS SHALL NOT EXCEED 3-1/2' ANYWHERE WITHIN 50' OF A STREET INTERSECTION.
2. IN ZONE "C" COMMERCIAL DISTRICTS, FENCES, WALLS, HEDGES AND OTHER OBSTRUCTIONS SHALL NOT EXCEED 3-1/2' ANYWHERE WITHIN 15' OF THE STREET INTERSECTION.
3. TREES WITHIN HEIGHT LIMITATION AREA SHALL HAVE FOILAGE REMOVED BELOW 5 FOOT HEIGHT.
4. CHECK WITH CITY FOR PROPER SETBACK REQUIREMENTS.
5. REF: ( ORD. 822 CS § 2 (PART) 1975: PRIOR CODE § 10.114.4) - MMC 22.34.090)

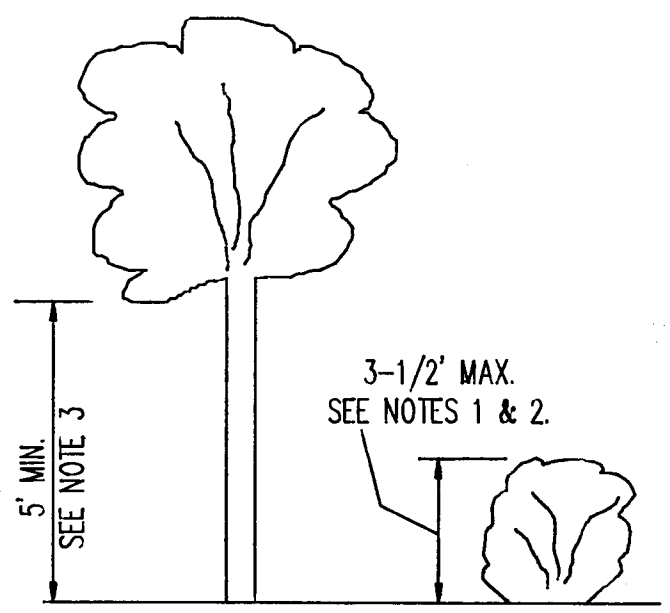

APPROVED BY: *Richard P. Cullen* DATE: 5/30/90  
 PUBLIC SERVICES DIRECTOR R.C.E. 23797

CITY OF MARTINEZ  
 INTERSECTION  
 SIGHT DISTANCE

SCALE: NONE
STD. DRWG. NO. T-5
SHEET 1 OF 1

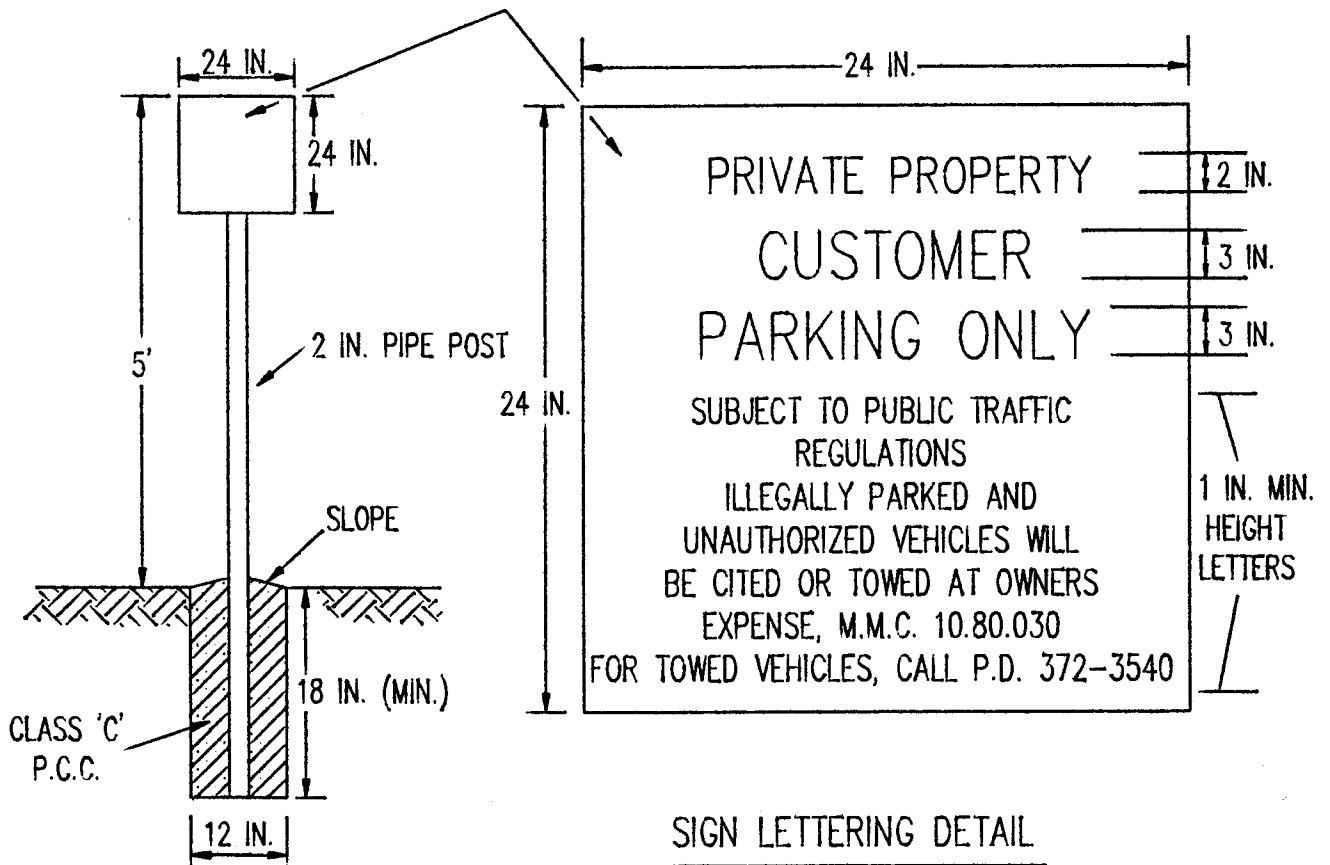

POLE DETAIL

SIGN LETTERING DETAIL

NOTES:

1. SIGN SHALL BE MADE ON FLAT ALUMINUM PLATE WITH A MINIMUM THICKNESS OF 0.080 IN., WITH BLACK LETTERS ON A WHITE BACKGROUND.
2. 3 IN. HIGH LETTER MESSAGE SHALL INDICATE LIMITS OF ENFORCEMENT SUCH AS: "NO PARKING AT ANYTIME," "PRIVATE PARKING," "CUSTOMER PARKING ONLY," "TENANT PARKING ONLY," ETC..
3. SIGN SHALL BE INSTALLED BY THE PROPERTY OWNER, AT EACH PARKING LOT ENTRANCE.
4. PROPERTY OWNER SHALL BE RESPONSIBLE FOR PROPER MAINTENANCE OF THE SIGN.
5. SIGN SHALL BE LOCATED SO AS NOT TO CONFLICT WITH PEDESTRIAN TRAFFIC.
6. REF: C.V.C. SEC. 21107.8



APPROVED BY:

DATE 5/30/90

*Richard P. Cullen*  
PUBLIC SERVICES DIRECTOR R.C.E. 23797

CITY OF MARTINEZ

PRIVATE PROPERTY  
PARKING SIGN

SCALE: NONE  
STD. DRWG.

NO.  
T-6

SHEET 1 OF 1

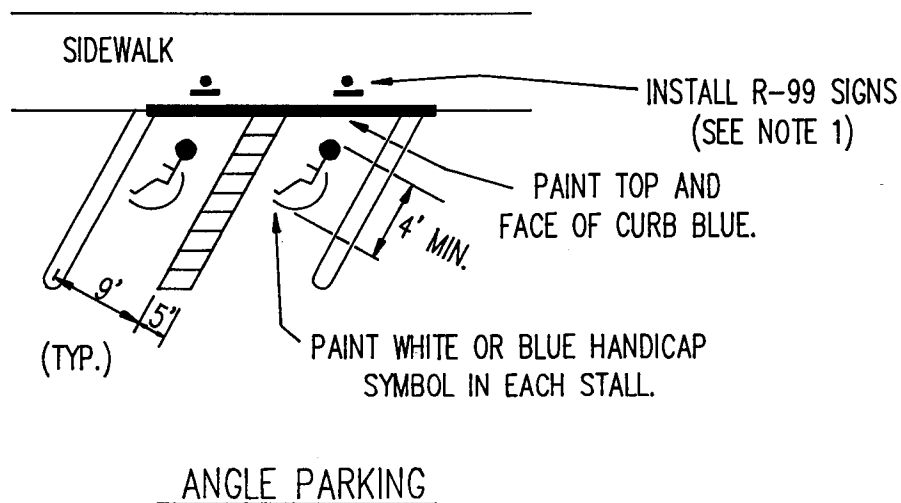
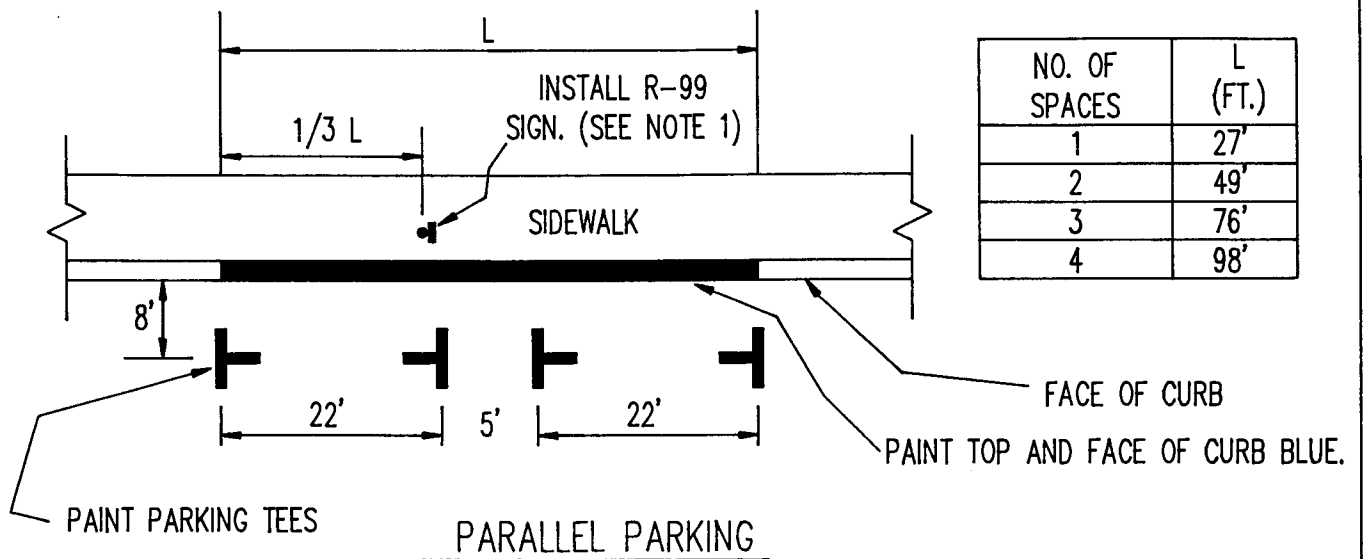

NOTES:

1. R99 SIGN SHALL CONFORM TO STATE OF CALIFORNIA STANDARD SPECIFICATIONS. ALSO USE R100B "UNAUTHORIZED VEHICLES.....WILL BE TOWED..." SIGN WHEN DIRECTED BY CITY.
2. SIGNS SHALL BE MOUNTED ON 2 IN. GALVANIZED POSTS. LOCATE 2' BEHIND CURB FACE. HEIGHT TO BOTTOM OF SIGN SHALL BE 7' WITHIN SIDEWALK AREAS AND 4' WITHIN LANDSCAPE AREAS OR WHEN SIGN IS MOUNTED ON A WALL.
3. ONE SIGN SHALL BE INSTALLED FOR EACH 2 PARALLEL SPACES AND ONE FOR EACH ANGLE SPACE.
4. HANDICAP PARKING SPACES SHALL BE LOCATED SO AS TO MINIMIZE THE NEED FOR HANDICAPPED PERSONS TO PASS BEHIND PARKED VEHICLES IN PROCEEDING FROM THEIR VEHICLE TO HANDICAP RAMPS.



APPROVED BY:

DATE: 5/30/90

*Richard R. Cullen*  
PUBLIC SERVICES DIRECTOR R.C.E. 23797

CITY OF MARTINEZ

HANDICAP PARKING

SCALE: NONE  
STD. DRWG. NO. T-7  
SHEET 1 of 1

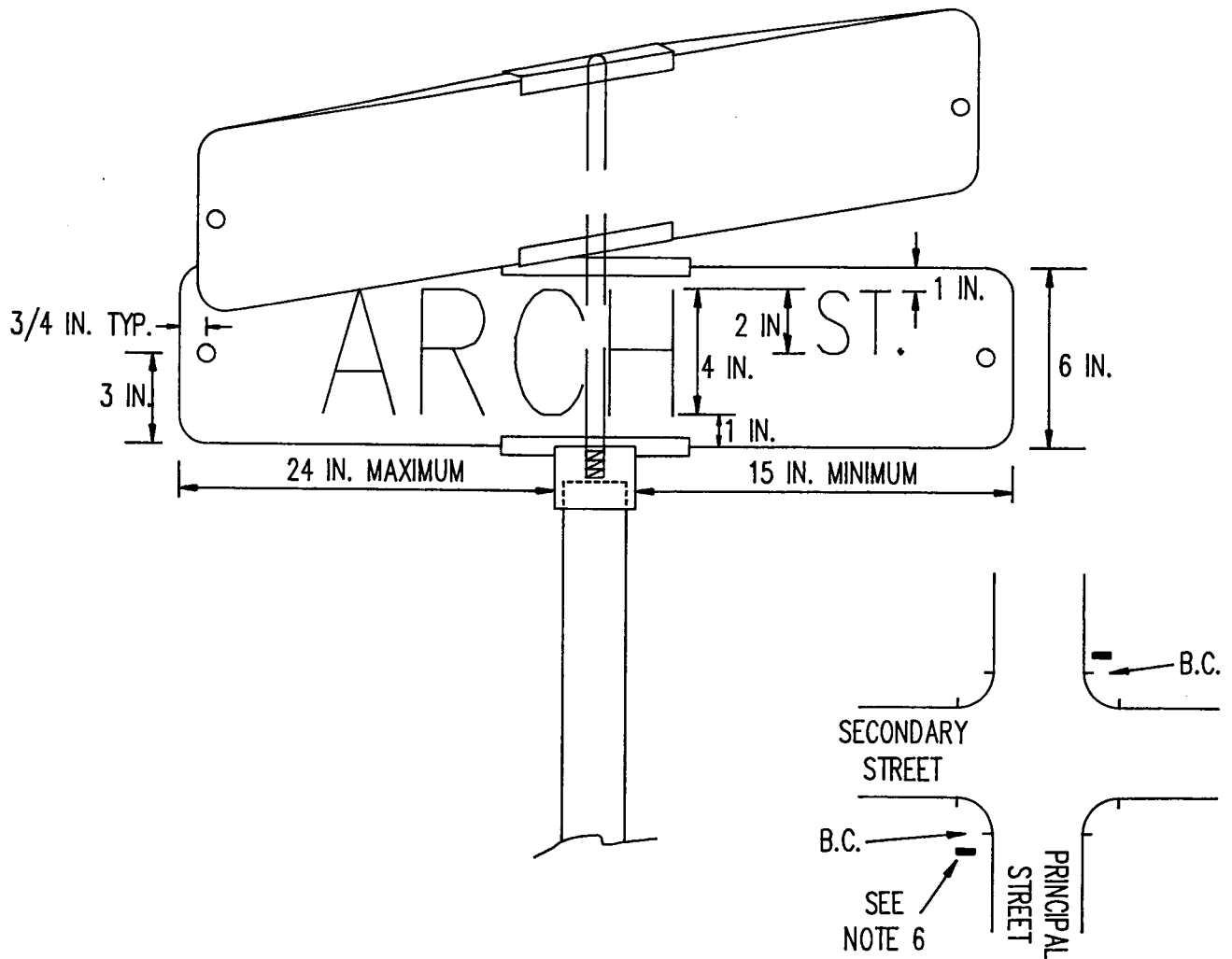

NOTES:

1. SIGN PLATES SHALL BE FLAT ALUMINUM, 0.080 GAUGE.
2. SIGNS SHALL BE 4 - PLATE ASSEMBLY.
3. SIGN PLATES SHALL HAVE ALL REFLECTIVE SHEETING; PROVIDE HAWKINS MIDNITE BLUE OR APPROVED EQUAL BACKGROUND AND SILVER LETTERS.
4. ASSEMBLY HARDWARE SHALL BE HOT-DIPPED GALVANIZED STEEL OR ALUMINUM WITH MOUNTING SCREW EXTENDING THROUGH SIGNS.
5. SIGN POST SHALL BE 2-3/8 IN. O.D. GALVANIZED IRON PIPE WITH LOWEST SIGN LOCATED 7' ABOVE GROUND.
6. ONE SIGN POST INSTALLED PER INTERSECTION PER CITY STANDARD NO. T-1 AND LOCATED AT B.C. OF PRINCIPAL STREET ON FAR SIDE OF INTERSECTION.
7. ABBREVIATE STREET SUFFIX; USE "PRIVATE" DESIGNATION ON PRIVATE STREETS WITH 1 IN. CAPITAL LETTERS UNDER STREET SUFFIX.

APPROVED BY: <i>Richard P. Cullen</i> PUBLIC SERVICES DIRECTOR R.C.E. 23797	DATE: 6/21/90	CITY OF MARTINEZ	SCALE: NONE
	STREET NAME SIGNS	STD. DRWG. NO. T-8	SHEET 1 OF 1

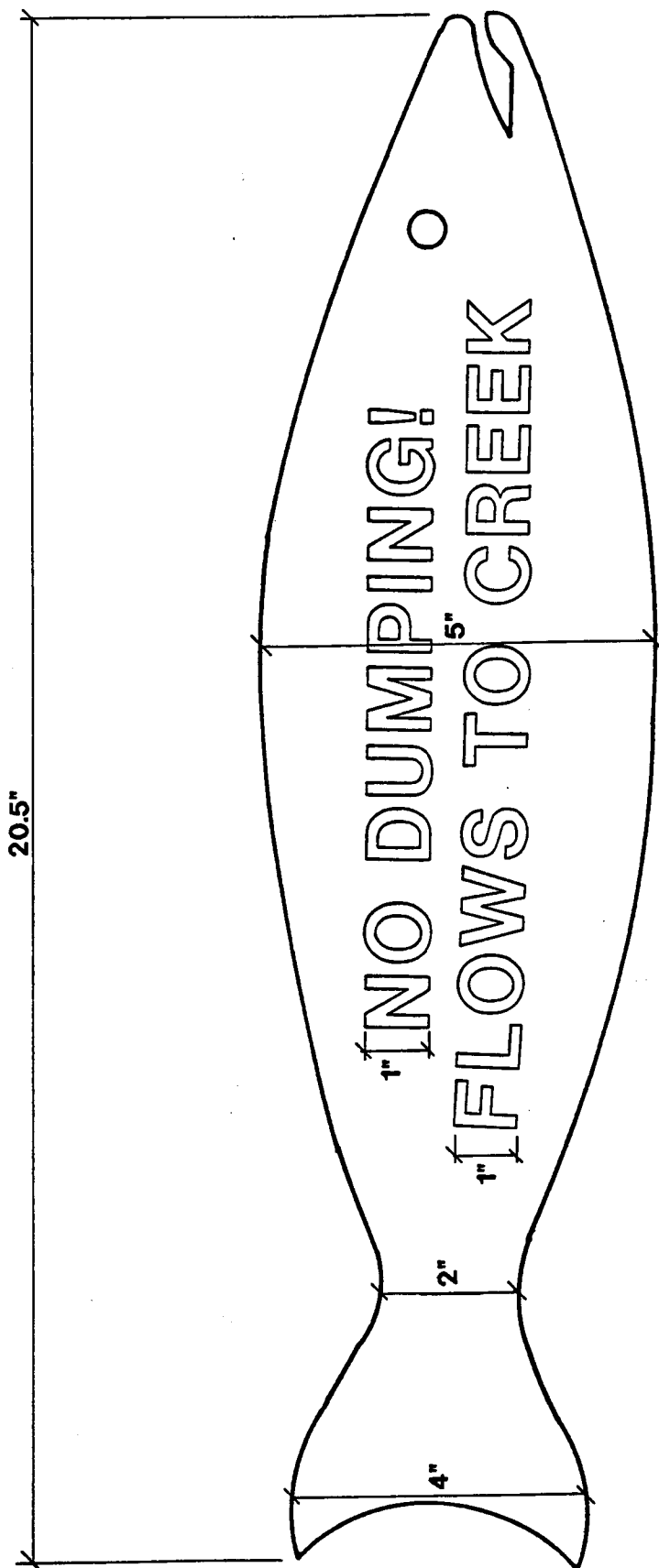

APPROVED BY: DATE:

*Karenth Eubank* 6/29/94  
 CITY ENGINEER, R.C.E. 13456

CITY OF MARTINEZ

Catch Basin  
 Stencil

SCALE: NONE  
 STD. DRWG.  
 NO.  
 SD-1  
 SHEET 1 OF 2

NOTE: Stencil kits will be provided by City upon receipt of a refundable deposit.

**SPECIFICATIONS**

FISH: LENGTH: 20 1/2 INCHES  
HEIGHT: 5 INCHES

LEGEND: 1 INCH LETTERING

MESSAGE: NO DUMPING!  
FLOWS TO CREEK

COLORS: FISH: AERVO, LIGHT BLUE, GROUND TRAFFIC COATING\*  
MESSAGE: AERVO, WHITE, GROUND TRAFFIC COATING\*  
\* = OR APPROVED EQUAL

**APPLICATION PROCEDURE:**

1. Brush area on top of curb to be stenciled with wire brush.
2. Sweep area with whisk broom.
3. Place fish stencil on top of curb (see note below for stencil orientation).
4. Mark curb along border of stencil with masking tape.
5. Shake paint can and apply light blue paint using long sweeping motion. Do not over apply paint.
6. Let paint dry to touch.
7. Align message stencil with masking tape. Blue paint should be visible under all letters.
8. Shake paint can and apply white paint using long sweeping motions. Do not over apply.

**STENCIL ORIENTATION:**

1. No sidewalks, message directed toward street.
2. Existing sidewalks, message directed toward sidewalk.

APPROVED BY: <i>Kenneth Eschbar</i> CITY ENGINEER, R.C.E. 13456	DATE: 6/29/94	CITY OF MARTINEZ	SCALE: NONE
		Catch Basin Stencil	STD. DRWG. NO. SD-1
		SHEET 2 OF 2	

WHEN INLET IS PRECAST, USE 50" DIAMETER PRECAST TRANSITION SLAB, SANTA ROSA CAST PRODUCTS CO. DWG. NO. 100-100-001, OR EQUIVALENT.

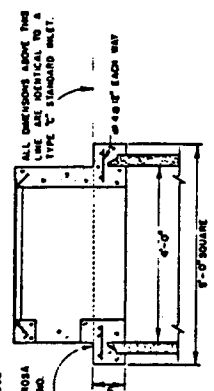

SECTION OF TYPE "C" OPENING ON PRECAST MANHOLE BARREL  
4'-0" x 1'-0"  
REFER TO STANDARD PLAN CC 3020

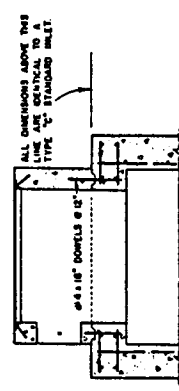

SECTION OF TYPE "C" OPENING ON MANHOLE BASE  
4'-0" x 1'-0"  
REFER TO STANDARD PLAN CC 3021

WHEN INLET IS PRECAST, USE 50" DIAMETER PRECAST TRANSITION SLAB, SANTA ROSA CAST PRODUCTS CO. DWG. NO. 100-100-001, OR EQUIVALENT.

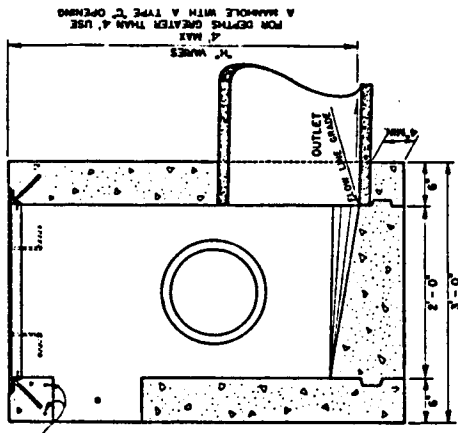

SECTION B-B  
1'-0" x 1'-0"

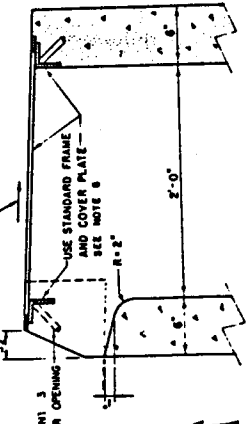

SECTION B-B CURB OPENING MODIFICATION  
3'-0" x 1'-0"

ADVANCED STEEL CONCRETE AND CURB SIDE FRAME (SEE STANDARD PLAN CC 3010) SEE NOTE 6

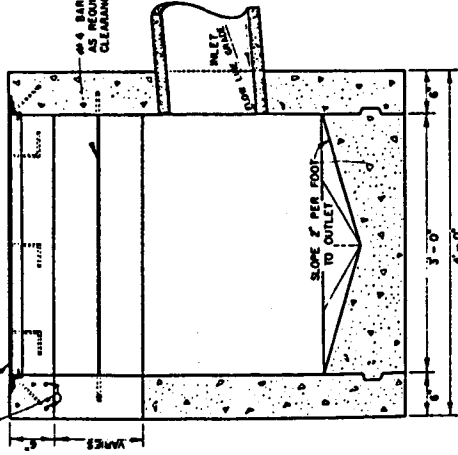

SECTION A-A  
1'-0" x 1'-0"

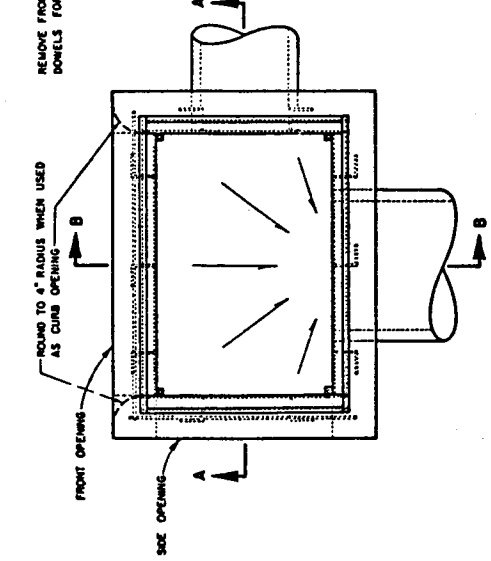

PLAN  
1'-0" x 1'-0"  
CONCRETE NOT SHOWN

NOTES:  
1. CONSTRUCTION DETAILS ARE OPTIONAL WHERE SHOWN. OTHER LOCATIONS ARE SUBJECT TO THE APPROVAL OF THE ENGINEER. SET DIMENSIONS - 2 1/4" x 2 1/4".  
2. ALL DIMENSIONS ARE TO FACE UNLESS OTHERWISE NOTED.  
3. CURB AND INLET PIPES SHALL NOT INTERSECT AND NOT THROUGH A CORNER. IF THE PIPE IS TOO LARGE ON THE SLOPE, MAKE IT TOO GREAT TO PERMIT THE OPENING TO BE MADE IN A SINGLE WALL. USE A MANHOLE BASE WITH A TYPE "C" INLET OPENING ON TOP OF THE CURB. THE LOCATION OF THE OPENING SHALL BE AS SHOWN ON PLANS OR AS OTHERWISE DETERMINED BY ENGINEER.  
4. ALL INLETS SHALL BE CONSTRUCTED WITH GRATE UNLESS THE INLET IS TO BE IN REINFORCED CONCRETE. THE GRATE SHALL BE CONFORMANT TO SANTA ROSA CAST PRODUCTS CO. DRAWING NO. BR001. OR EQUIVALENT, CAN BE SUBSTITUTED FOR CAST-IN-PLACE INLET.

CONTRA COSTA COUNTY PUBLIC WORKS DEPARTMENT MARTINEZ, CALIFORNIA		STANDARD PLAN	
TYPE "C" INLET		TYPE "C" INLET	
NO.	DATE	REVISION	DESCRIPTION
1	2-21-78		PRECAST INLET NOTES ADDED
2	4-28-78		REFERENCE NOTE #6 ADDED
3	9-8-84		CURB OPENING MODIFICATION ADDED
4	2-1-87		REFERENCE NOTES ADDED
5			
6			
7			
8			
9			
10			

*James J. Davis*  
PUBLIC WORKS DIRECTOR - R.E. CERT. NO. 7837



**NOTES**

- TYPE "D" INLET NOT PERMITTED WHEN STREET GRADE EXCEEDS 8% OF GRADE EXCEEDS 8%, USE TYPE "E" INLET
- PRECAST CONCRETE CURB INLET TO BE SANTA ROSA CAST PRODUCTS CO MODEL 4A, OR CHRISTY CONCRETE PRODUCTS MODEL U-37, OR EQUAL, AS APPROVED BY THE PUBLIC WORKS DEPARTMENT. SEE MANUFACTURER'S CATALOG FOR DETAILS OF INLET AND CIRCULAR COVER NOT SHOWN ON THIS PLAN. PROVIDE PCE HOLE TO ADJ. LIFTING COVER.
- CONCRETE MANHOLE SHALL BE CONSTRUCTED IN ACCORDANCE WITH THE PLAN AND SIDEWALK WHICH IS DETACHED, SHALL BE SET-OUT AT A TRUE SECTION 4 CURB AND SIDEWALK SHALL BE CONSTRUCTED MONOLITHICALLY 5' W/4" EXCEEDS 8", CONSTRUCT PRE-CAST INLET ON THIS PLAN REFERENCE MANHOLE BASE AS SHOWN IN DETAIL "D" ON THIS PLAN.
- STANDARD PLANS CC 3021 & CC 3022 FOR MANHOLE BASE DETAILS.
- A PIPE SHALL NOT ENTER THE INLET THROUGH A CORNER IF PIPE EXCEEDS MINIMUM DIAMETER ALLOWED. USE SECTION 8-A, OR THE SAKER SHALL BE CONSTRUCTED AS SHOWN IN DETAIL "D".
- CONSTRUCT TYPE III ON TYPE III MANHOLE BASE TO ACCOMMODATE THE PRE-CAST INLET. SEE DETAIL "D".
- BACK FOR WEEDHOLE PERMEABLE MATERIAL TO BE 10 OZ BURLAP MEASURING 1' x 3' WHEN LAD FLAT.

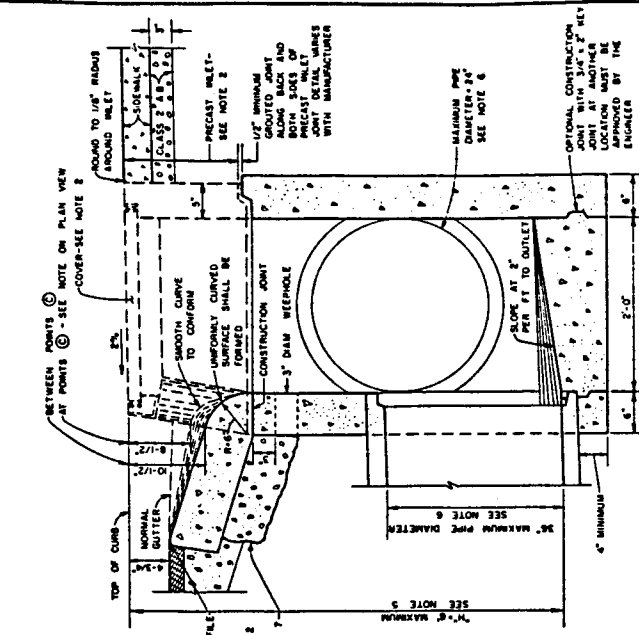
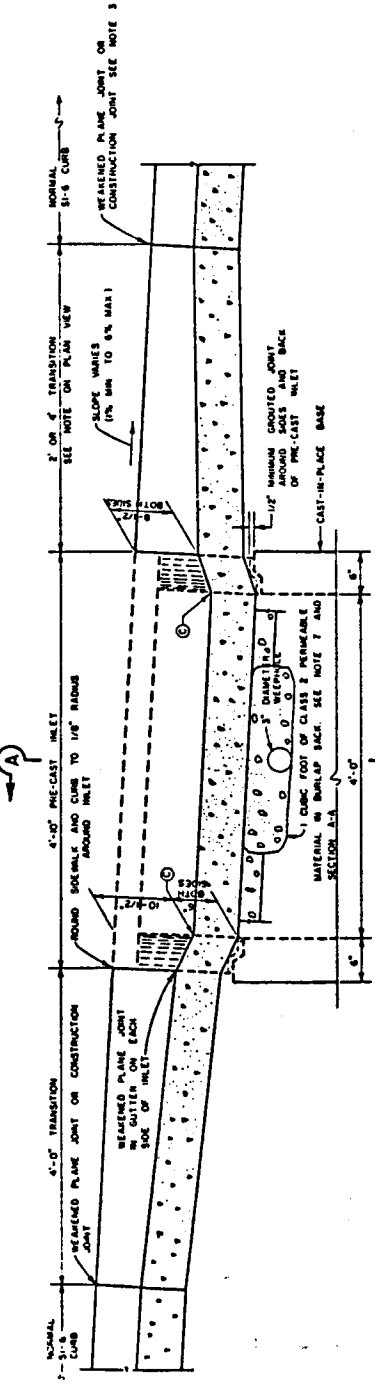

**SECTION A-A**

PRECAST INLET INDICATED BY BROKEN LINES  
 CAST-IN-PLACE CONSTRUCTION INDICATED BY SOLID LINES  
 CONCRETE BELOW CONSTRUCTION JOINT SHALL BE CLASS A.

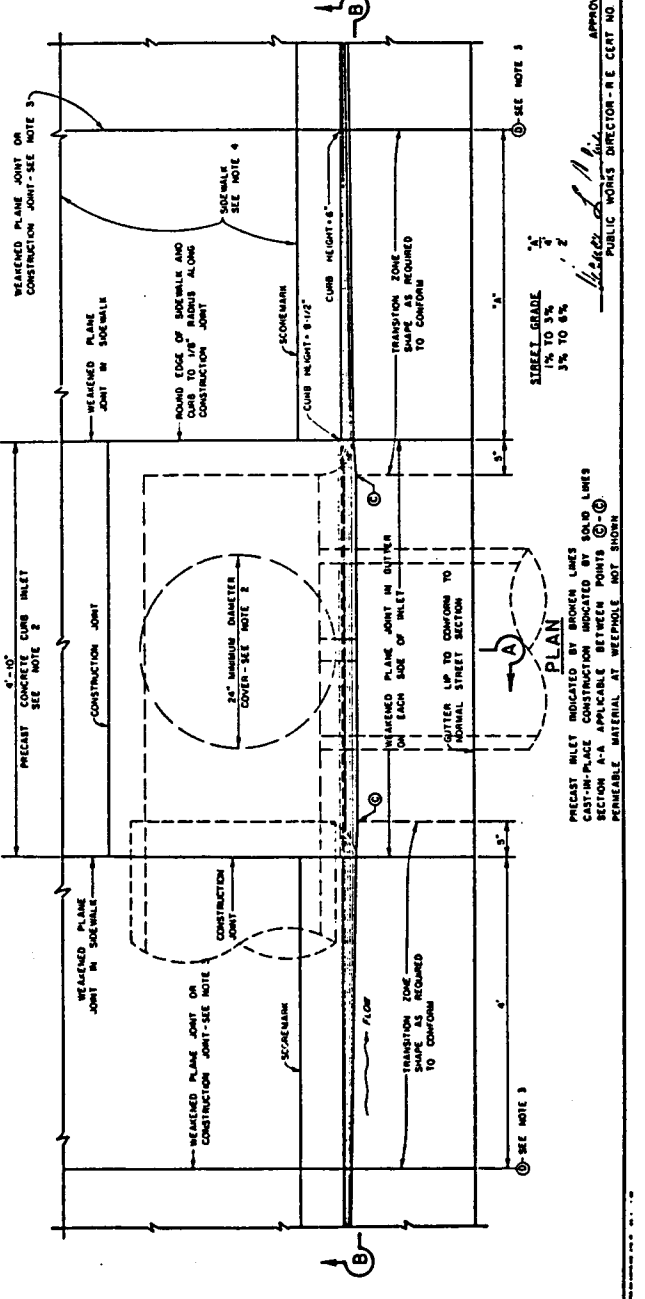
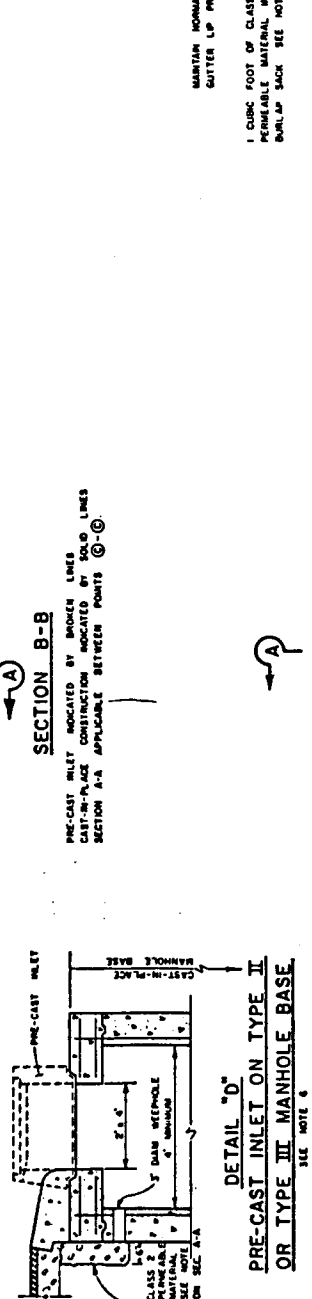

CONTRA COSTA COUNTY  
 PUBLIC WORKS DEPARTMENT  
 MARTINEZ, CALIFORNIA

NO.	DATE	DESCRIPTION	BY	CHKD.
1	10/15/76	DESIGN	J. B. ...	...
2	10/15/76	DESIGN	J. B. ...	...
3	10/15/76	DESIGN	J. B. ...	...

TYPE "D" INLET

APPROVED: *[Signature]*  
 PUBLIC WORKS DIRECTOR - RE CERT NO. 7957

DATE: 10/15/76

PRECAST INLET INDICATED BY BROKEN LINES  
 CAST-IN-PLACE CONSTRUCTION INDICATED BY SOLID LINES  
 SECTION A-A APPLICABLE BETWEEN POINTS (A)-(B)  
 PERMEABLE MATERIAL AT WEEDHOLE NOT SHOWN

CONTRA COSTA COUNTY  
 PUBLIC WORKS DEPARTMENT  
 MARTINEZ, CALIFORNIA



**NOTES**

- 1 THE PRECAST CONCRETE CURB INLET SHALL BE ORIENTED CONCRETE PRODUCTS MODEL U-31, OR SANTA ROSA CAST PRODUCTS CO MODEL 4A, OR EQUAL AS APPROVED BY THE PUBLIC WORKS DEPARTMENT SEE MANUFACTURER'S CATALOG FOR DETAILS OF INLET AND CURB. COVER NOT SHOWN ON THIS PLAN PROVIDE PRECAST CONCRETE CURB PRODUCTS AS APPROVED BY THE PUBLIC WORKS DEPARTMENT.
- 2 CURB AND SIDEWALK ARE EXTENDED, CONSTRUCTION JOINTS SHALL BE PROVIDED AT LOCATIONS AS SHOWN ON THE PLAN VIEW EXTENDED CURB AND SIDEWALK WHICH IS DEFORMED, SHALL BE SPLIT AT A TRUE SECTION.
- 3 CURB AND SIDEWALK SHALL BE CONSTRUCTED MONOLITHICALLY.
- 4 IF "X" EXCEEDS 6", CONSTRUCT PRECAST INLET ON A TYPE II OR TYPE III MANHOLE. IF "X" EXCEEDS 12", CONSTRUCT INLET ON STANDARD PLAN FOR MANHOLE BASE DETAILS. REFERENCE: STANDARD PLANS CC 3031 & 3032.
- 5 A PIPE SHALL NOT ENTER THE INLET THROUGH A CORNER. IF PIPE EXCEEDS MAXIMUM DIAMETER ALLOWED, (SEE SECTION A-A), OR THE SHAPE ANGLE PREVENTS THE PIPE OPENING FROM BEING MADE IN A SINGLE WALL, CONSTRUCT A TYPE II OR TYPE III MANHOLE BASE TO ACCOMMODATE THE PRECAST INLET. SEE DETAIL "D" ON STANDARD PLAN CC 3031.
- 6 CONSTRUCTION OF GALLERY TO INSIDE FACE OF BASE, AND FALL IN BACK FOR WEEPHOLE PERMEABLE MATERIAL TO BE 9" OR BURLAP MEASURING 18" x 36" WHEN Laid FLAT.

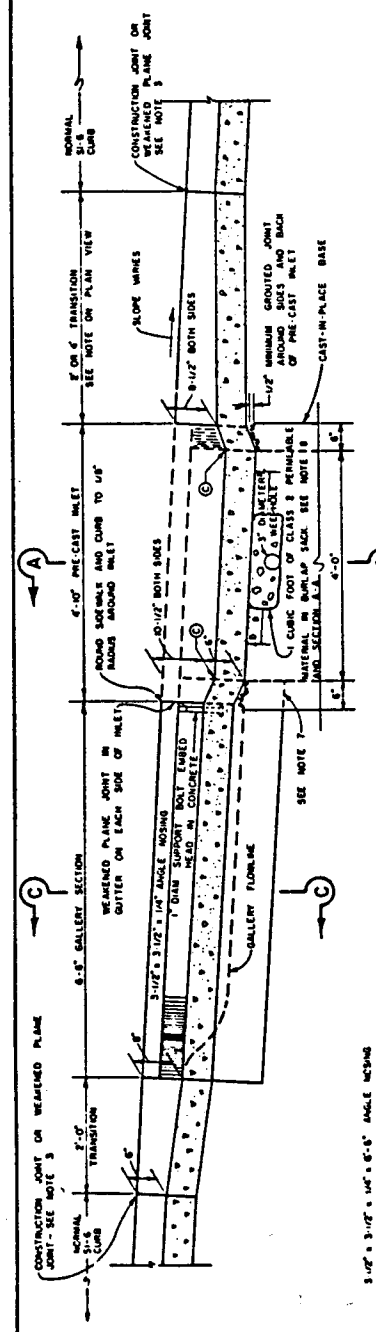

**SECTION B-B**

PRECAST INLET INDICATED BY BROKEN LINES  
 CAST-IN-PLACE CONSTRUCTION INDICATED BY SOLID LINES  
 SECTION A-A APPLICABLE BETWEEN POINTS A-A



**SECTION C-C**

DIMENSIONS FROM 5\"/>
 SOFTWALL AND GALLERY SECTION TO BE CONSTRUCTED MONOLITHICALLY.  
 CONCRETE REQUIREMENTS:  
 BELOW CONSTRUCTION JOINTS - CLASS A  
 ABOVE CONSTRUCTION JOINTS - CLASS B

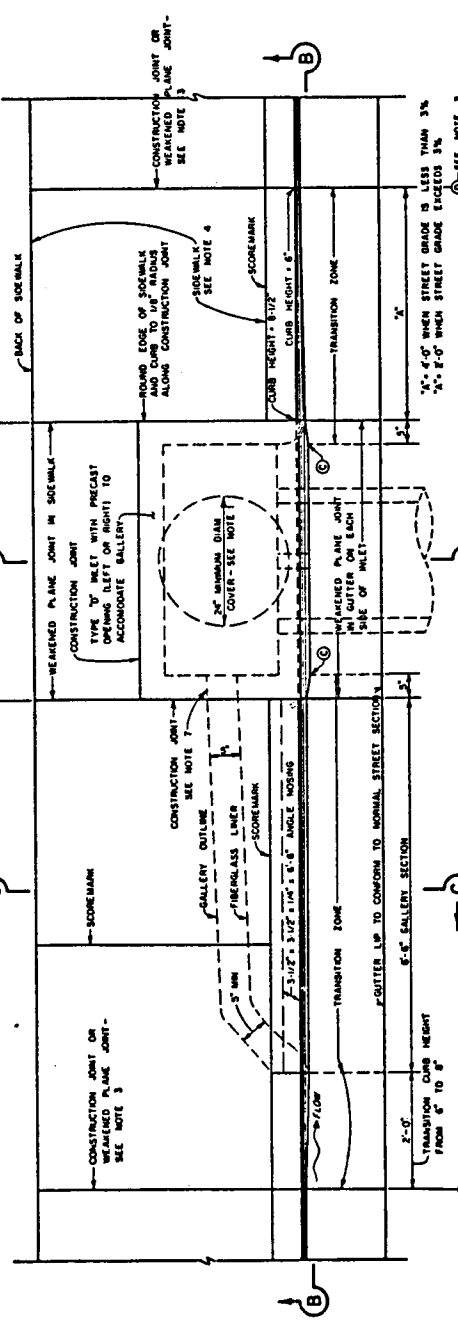

**PLAN**

PRECAST INLET INDICATED BY BROKEN LINES  
 CAST-IN-PLACE CONSTRUCTION INDICATED BY SOLID LINES  
 SECTION A-A APPLICABLE BETWEEN POINTS A-A  
 PERMEABLE MATERIAL AT WEEPHOLE NOT SHOWN

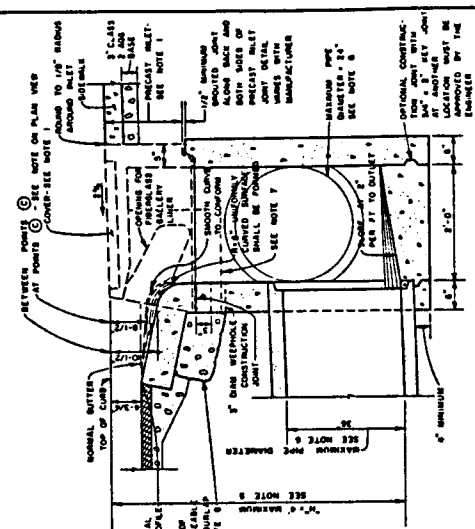

**SECTION A-A**

PRECAST INLET INDICATED BY BROKEN LINES  
 CAST-IN-PLACE CONSTRUCTION INDICATED BY SOLID LINES  
 CONCRETE BELOW CONSTRUCTION JOINT SHALL BE CLASS A

CONTRA COSTA COUNTY  
 PUBLIC WORKS DEPARTMENT  
 MATTHEW CALABRESA

**TYPE "E" INLET**

REV	DATE	DESCRIPTION	BY	CHK
1	11-1-74	ADDED POH HOLE	CLG	ALN
2	11-1-74	REVISIONS TO INLET	CLG	ALN
3	11-1-74	REVISIONS TO INLET	CLG	ALN

FILE NO. CC 3017 SHEET 1 OF 1

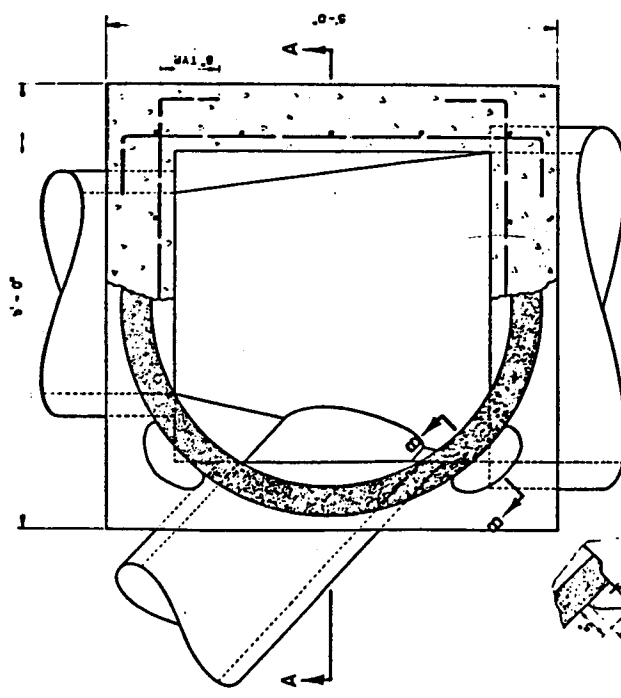

SECTION B-B

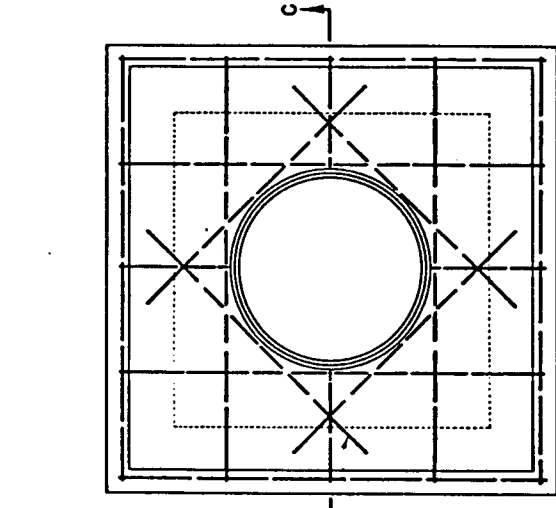

PLAN

PRECAST MANHOLE SECTION WHERE THERE IS NOT SUFFICIENT CLEARANCE BETWEEN THE TOP OF THE MANHOLE BASE AND FINISH GRADE FOR PRECAST SECTION, USE TOP SLAB.

SECTION A-A

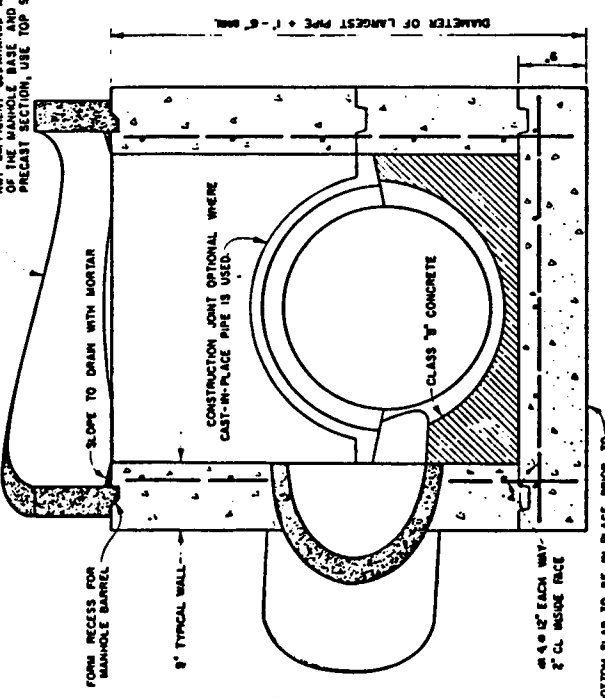

SECTION A-A

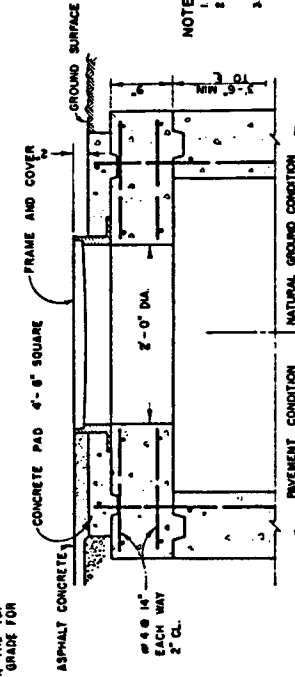

SECTION C-C

TOP SLAB

USE TOP SLAB:  
 1. WHERE THERE IS NOT SUFFICIENT CLEARANCE BETWEEN THE TOP OF THE MANHOLE BASE AND FINISH GRADE FOR PRECAST SECTION, USE TOP SLAB.  
 2. WHERE THERE IS SUFFICIENT CLEARANCE BETWEEN THE TOP OF THE MANHOLE BASE AND FINISH GRADE FOR PRECAST SECTION, USE TOP SLAB.  
 3. WHERE THERE IS SUFFICIENT CLEARANCE BETWEEN THE TOP OF THE MANHOLE BASE AND FINISH GRADE FOR PRECAST SECTION, USE TOP SLAB.  
 4. WHERE THERE IS SUFFICIENT CLEARANCE BETWEEN THE TOP OF THE MANHOLE BASE AND FINISH GRADE FOR PRECAST SECTION, USE TOP SLAB.

NOTES:

1. ALL REINFORCED CONCRETE SHALL BE CLASS "A".
2. CONSTRUCTION JOINTS ARE OPTIONAL WHERE SHOWN. OTHER LOCATIONS ARE SUBJECT TO THE APPROVAL OF THE ENGINEER.
3. ALL DIMENSIONS ARE IN FEET AND INCHES UNLESS OTHERWISE NOTED. DIMENSIONS SHALL NOT INTERCEPT A MANHOLE BASE THROUGH A CORNER IF THE SKEW ANGLE IS TOO SHARP TO PERMIT THE OPENING TO BE MADE IN A SINGLE WALL. USE A TYPE "B" MANHOLE BASE (SEE SHEET CC 3021) FOR USE WITH 48" DIAMETER MANHOLE BARS. TYPE "B" MANHOLE BASES ARE FOR USE WITH PIPES TO 30" IN DIAMETER AND WHERE THERE IS SUFFICIENT COVER TO USE A MINIMUM LENGTH MANHOLE BARREL. OCCURRING IN THE TOP SLAB AND COVER. TYPE "A" MANHOLE BASES ARE FOR USE WITH PIPES TO 30" IN DIAMETER. MANHOLE BASES FOR PIPES LARGER THAN 30" IN DIAMETER SHALL REQUIRE A SPECIAL DESIGN.
4. DETAILS OF PRECAST MANHOLE. SEE STANDARD PLAN CC 3000 FOR DETAILS OF MANHOLE FRAME AND COVER. SEE STANDARD PLAN CC 3001.

CONTRA COSTA COUNTY PUBLIC WORKS DEPARTMENT SUNNYVALE, CALIFORNIA	
STANDARD PLAN	
TYPE "B" II	
MANHOLE BASE	
NO.	DATE
1	12-14-72
2	ADD DATE 8
3	12-14-72
4	ADD DATE 8
5	12-14-72
6	ADD DATE 8
7	12-14-72
8	ADD DATE 8
9	12-14-72
10	ADD DATE 8
11	12-14-72
12	ADD DATE 8
13	12-14-72
14	ADD DATE 8
15	12-14-72
16	ADD DATE 8
17	12-14-72
18	ADD DATE 8
19	12-14-72
20	ADD DATE 8
21	12-14-72
22	ADD DATE 8
23	12-14-72
24	ADD DATE 8
25	12-14-72
26	ADD DATE 8
27	12-14-72
28	ADD DATE 8
29	12-14-72
30	ADD DATE 8
31	12-14-72
32	ADD DATE 8
33	12-14-72
34	ADD DATE 8
35	12-14-72
36	ADD DATE 8
37	12-14-72
38	ADD DATE 8
39	12-14-72
40	ADD DATE 8
41	12-14-72
42	ADD DATE 8
43	12-14-72
44	ADD DATE 8
45	12-14-72
46	ADD DATE 8
47	12-14-72
48	ADD DATE 8
49	12-14-72
50	ADD DATE 8
51	12-14-72
52	ADD DATE 8
53	12-14-72
54	ADD DATE 8
55	12-14-72
56	ADD DATE 8
57	12-14-72
58	ADD DATE 8
59	12-14-72
60	ADD DATE 8
61	12-14-72
62	ADD DATE 8
63	12-14-72
64	ADD DATE 8
65	12-14-72
66	ADD DATE 8
67	12-14-72
68	ADD DATE 8
69	12-14-72
70	ADD DATE 8
71	12-14-72
72	ADD DATE 8
73	12-14-72
74	ADD DATE 8
75	12-14-72
76	ADD DATE 8
77	12-14-72
78	ADD DATE 8
79	12-14-72
80	ADD DATE 8
81	12-14-72
82	ADD DATE 8
83	12-14-72
84	ADD DATE 8
85	12-14-72
86	ADD DATE 8
87	12-14-72
88	ADD DATE 8
89	12-14-72
90	ADD DATE 8
91	12-14-72
92	ADD DATE 8
93	12-14-72
94	ADD DATE 8
95	12-14-72
96	ADD DATE 8
97	12-14-72
98	ADD DATE 8
99	12-14-72
100	ADD DATE 8

PUBLIC WORKS DIRECTOR - R. E. CERT. NO. 5709 APPROVED March 26, 1965



GROUT HOLES (OPTIONAL)  
4-EQUALLY SPACED

MANHOLE FRAME

ASTM GRID PATTERN

BLIND PICK HOLE

STORM  
SEWER

EDGE PRY-HOLE

SET SCREWS FOR  
EXTENSION RING  
3-REQ'D EQUAL SPACING

1/32" MACHINED SURFACES

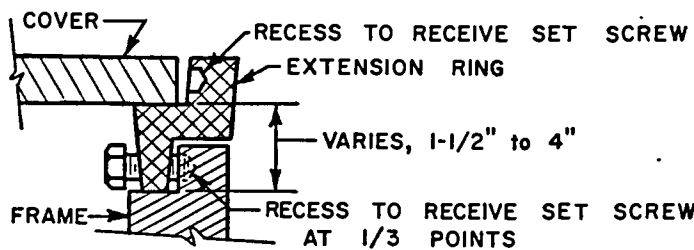
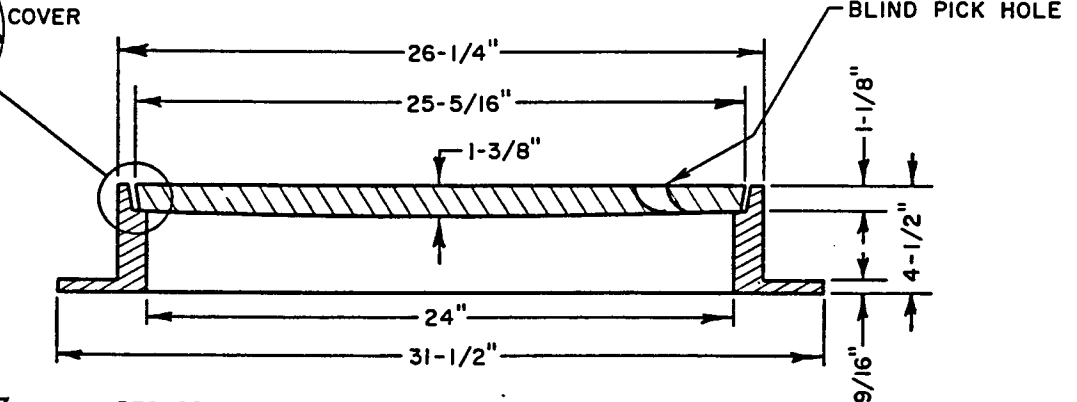
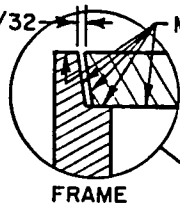

TYPICAL CAST IRON  
EXTENSION RING (NOT TO SCALE)

**NOTES**

I. MANHOLE FRAME AND COVER SHALL BE PHOENIX IRON WORKS(OAKLAND) MODEL P-1090 OR PINKERTON FOUNDRY(LODI) MODEL A-640 OR APPROVED EQUAL.

CONTRA COSTA COUNTY  
PUBLIC WORKS DEPARTMENT  
MARTINEZ CALIFORNIA

**MANHOLE FRAME AND COVER**

APPROVED: *Vernon L. Clive*  
PUBLIC WORKS DIRECTOR — R.E. CERT. NO. 7957

Scale: 1/8" = 1" Date: December 1976

Drawn by: FERNANDEZ ✓ File No.:

Checked by: TONELLI **CC 3024**

APPROVED *[Signature]* *[Signature]*  
 PUBLIC WORKS DIRECTOR RE CERT No 66370

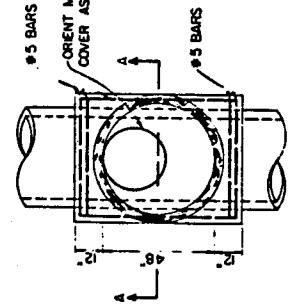

PLAN  
 TYPICAL MANHOLE BASE  
 30" thru 48" DIA.

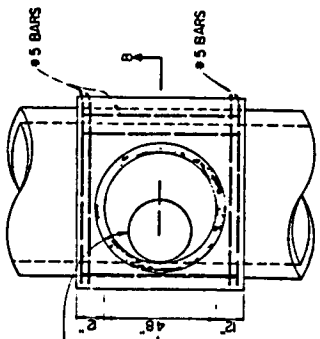

PLAN  
 TYPICAL MANHOLE BASE  
 54" thru 120" DIA.

DIMENSION TABLE										
DIA	A	B	C	D	E	F	G	H	J	
30"	46"	30"	9"	3"	56"	13"	3"	56"	30"	
36"	53"	36"	9 1/2"	3 1/2"	56"	10"	3 1/2"	56"	36"	
42"	60"	42"	10"	4"	60"	9"	4"	60"	42"	
48"	68"	48"	11"	5"	66"	9"	5"	60"	48"	
54"	75"	54"	11 1/2"	5 1/2"	75"	10 1/2"	5 1/2"	69"	48"	
60"	82"	60"	12"	6"	82"	11"	6"	70"	48"	
66"	89"	66"	12 1/2"	6 1/2"	89"	11 1/2"	6 1/2"	71"	48"	
72"	96"	72"	13"	7"	96"	12"	7"	72"	48"	
84"	110"	84"	14"	8"	110"	13"	8"	74"	48"	
96"	124"	96"	15"	9"	124"	14"	9"	76"	46"	
120"	154"	120"	18"	12"	154"	17"	12"	82"	48"	

USE OF AN 'X' > 64" REQUIRES A SPECIAL DESIGN

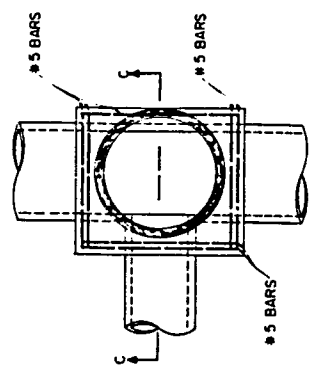

PLAN  
 TYPICAL LATERAL CONNECTION

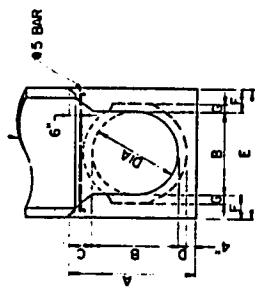

Section A-A

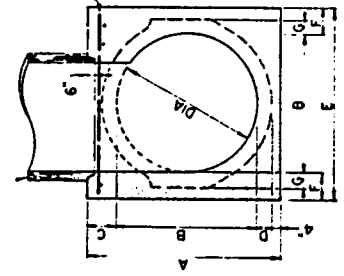

Section B-B

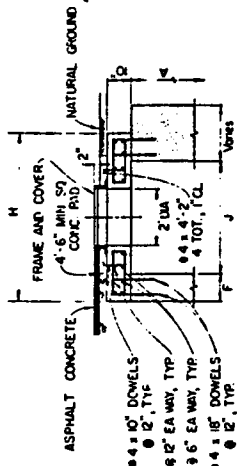

TOP SLAB  
 Section

- USE TOP SLAB:
- 1 WHERE THERE IS NOT SUFFICIENT CLEARANCE BETWEEN THE TOP OF THE MANHOLE BASE AND FINISH GRADE FOR A TYPE C CAST MANHOLE SECTION
  - 2 DIMENSION 'A' MAY BE INCREASED BEYOND THAT SPECIFIED IN ORDER TO CONFORM TO FINISH GRADE. USE OF A LARGER DIMENSION 'A' SHALL BE INDICATED ON THE DIMENSION TABLE IN ACCORDANCE WITH THE DIMENSION TABLE
  - 3 WHEN PLACING A TYPE 'A' OR A TYPE 'C' INLET ON A TYPE 'B' MANHOLE BASE THE OPENING IN THE TOP SLAB SHALL CONFORM TO THE INSIDE DIMENSION OF THE INLET BEING PLACED.

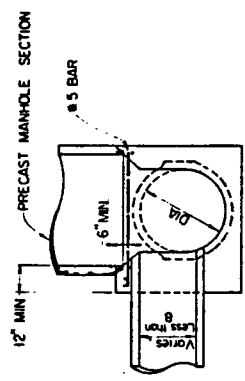

Section C-C

- NOTES
- 1 ALL CONCRETE SHALL BE CLASS A.
  - 2 CLEARANCE SHALL BE 2" FOR ALL STEEL, UNLESS OTHERWISE NOTED.
  - 3 THE TYPE III MANHOLE BASE, CC 3023, SHALL BE USED ONLY ON STRAIGHT RUNS OF CIPP OF THE SAME DIAMETER.
  - 4 FOR DETAILS OF PRECAST MANHOLE, SEE STANDARD PLAN CC 3020.
  - 5 FOR DETAILS OF MANHOLE FRAME AND COVER, SEE STANDARD PLAN CC 3024.

CONTRA COSTA COUNTY PUBLIC WORKS DEPARTMENT	
TYPE IV MANHOLE BASES	
CC 3025	

3-52

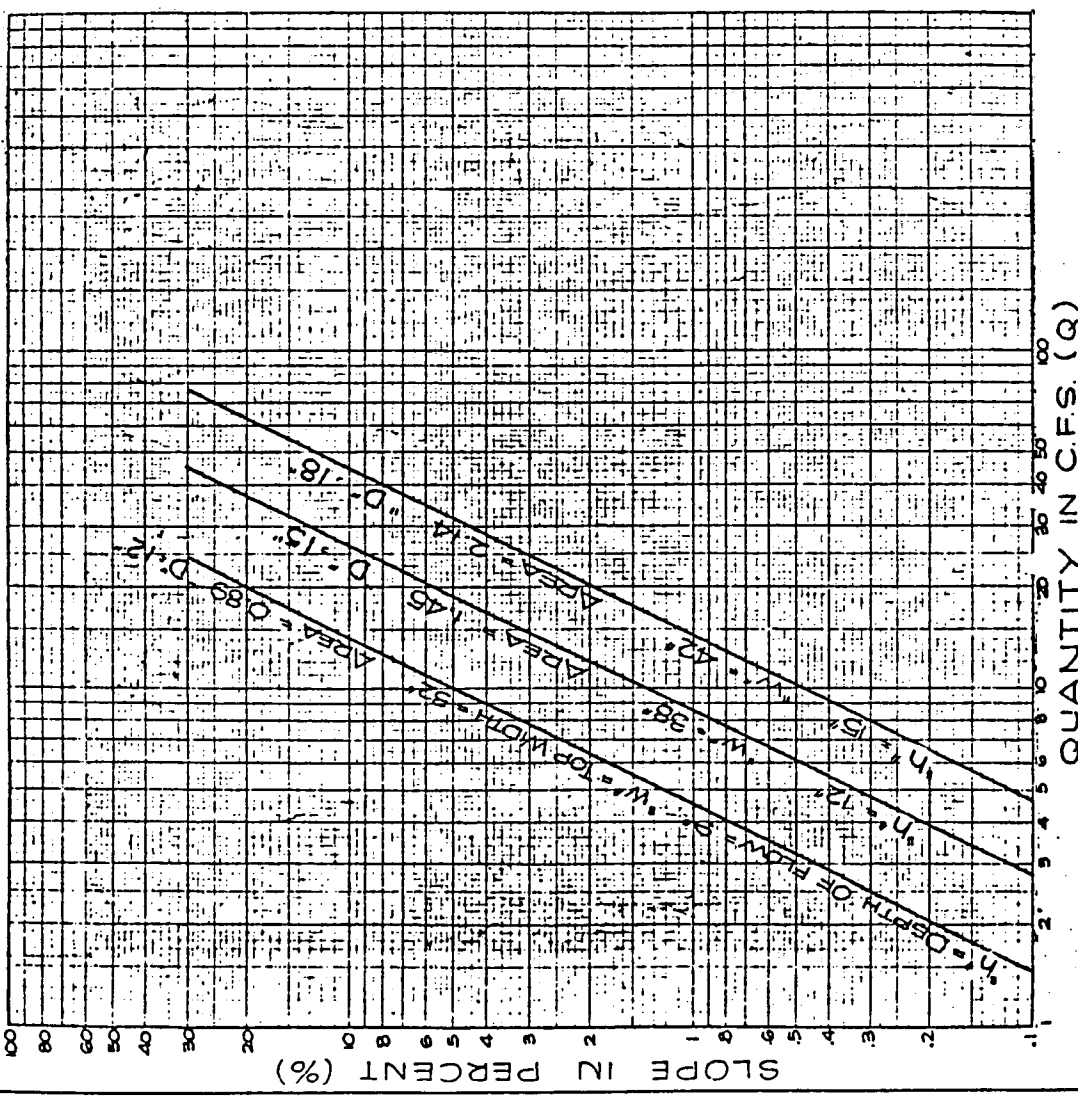

$0.5h^2 + 3h$

SEE:

- B-61 FOR CUTOFF WALL DETAILS
- B-62 FOR INLET STRUCTURE DETAILS
- B-63 FOR DITCH JUNCTION DETAILS
- B-65 FOR SUPERELEVATION WALL DETAILS

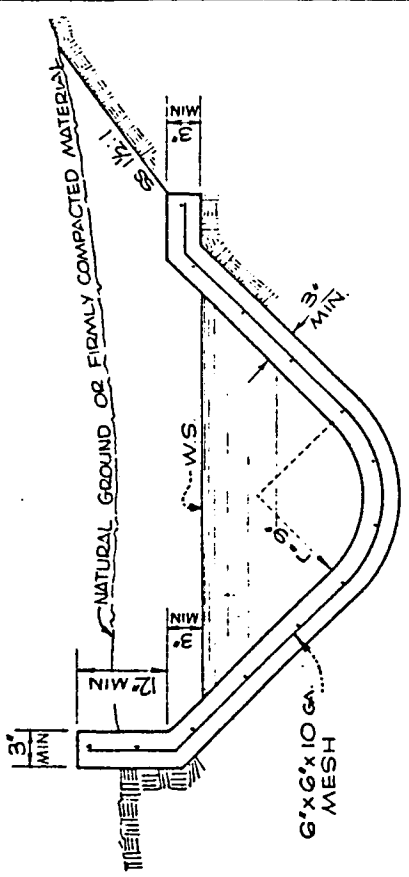

**SUPERELEVATED SECTION**  
USE ON OUTSIDE OF CURVES

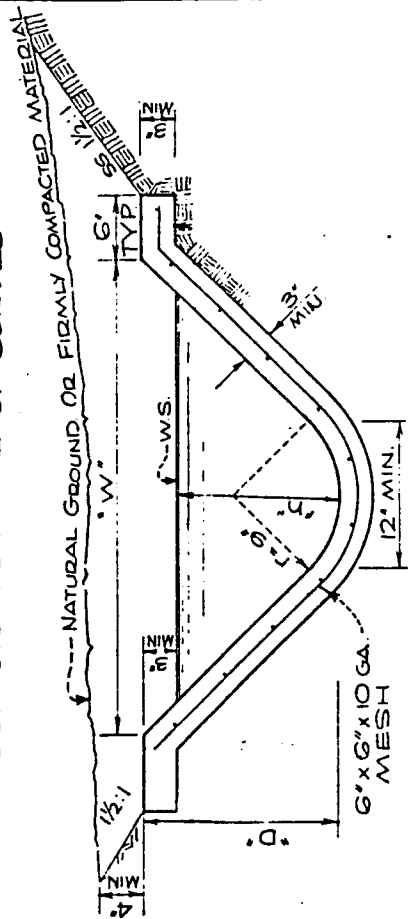

**NORMAL SECTION**

REVISIONS	DATE	DESCRIPTION

CONTRACT NO. 5-63  
DRAWN BY: H.C. DATE: 2-6-63  
CHECKED BY: H.P.B. DATE: 2-6-63  
APPROVED BY: [Signature] DATE: 2-6-63  
SCALE: NONE

CONTRA COSTA COUNTY  
FLOOD CONTROL and  
WATER CONSERVATION DISTRICT

DESIGN  
FOR CONCRETE LINED  
INTERCEPTER DITCH  
BY SECTION

7376 NO. B-58



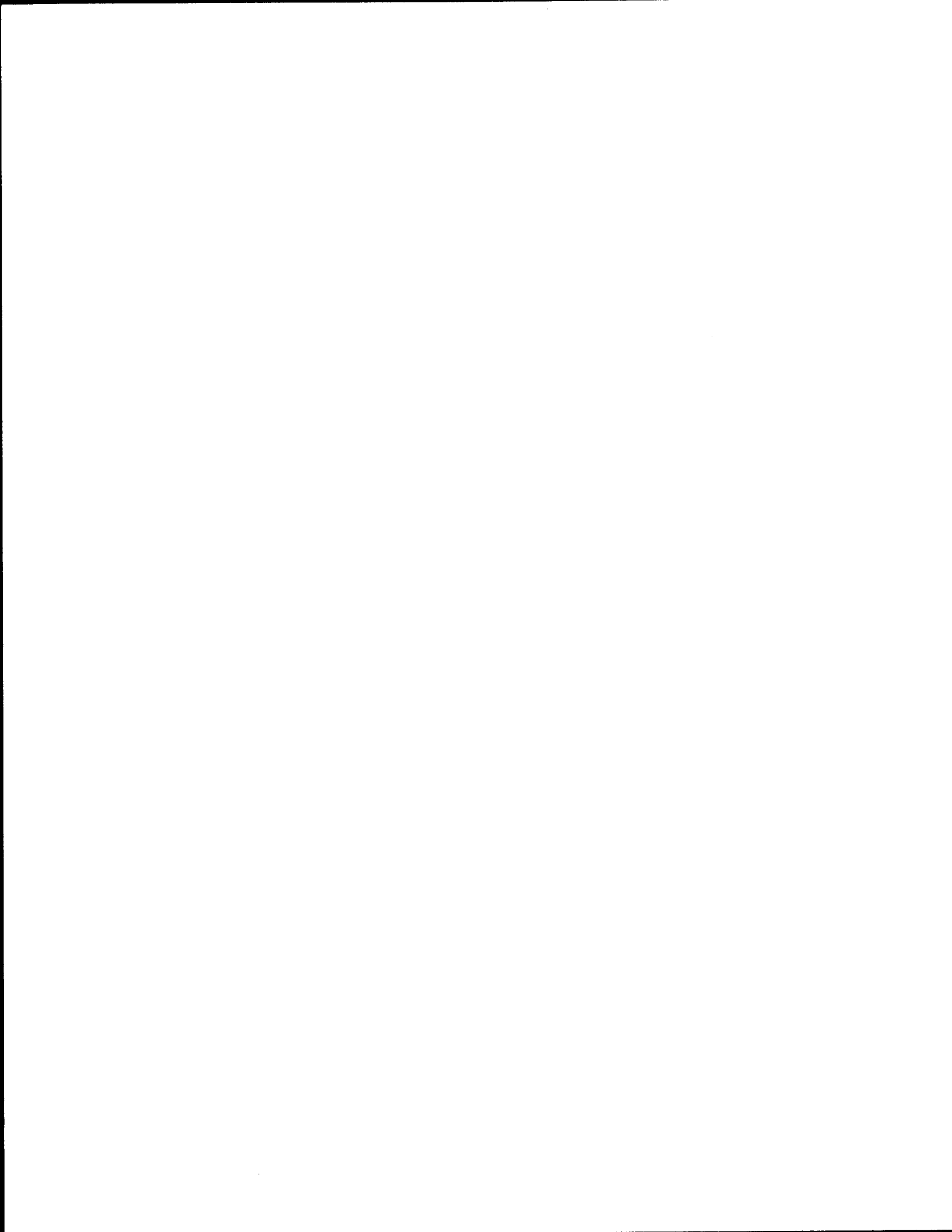

PREVAILING WIND DIRECTION →

TWIST EACH TIE AS SHOWN

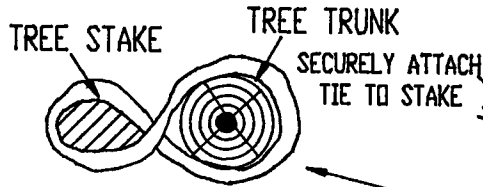

TREE TIE DETAIL  
NO SCALE

3/4" MIN. WIDE FLEXIBLE CORDED TIRE  
RUBBER OR HEAVY DUTY TIE RIBBON  
INSTALLED BELOW BASE OF CROWN.

TREATED LODGEPOLE STAKE,  
2" DIAM. X 10' LONG

HEADER AS REQUIRED

4" PERFORATED DRAIN PIPE  
WITH 3/4" WASHED DRAIN  
ROCK (2 PER TREE).

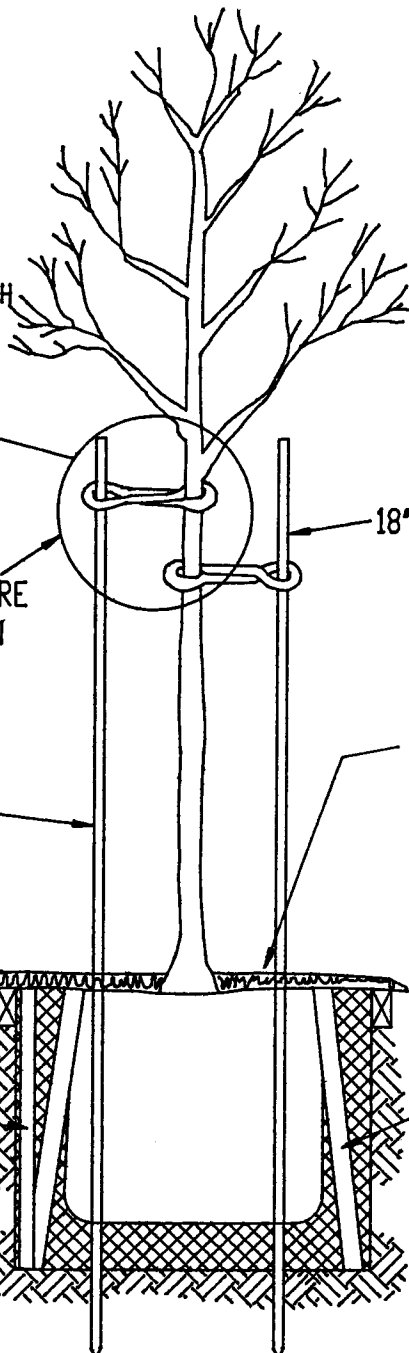

18" FROM TRUNK

2" LAYER MULCH

CONE SHAPED PLASTIC DEEP  
ROOT SHIELD REQUIRED IN  
AREAS ADJACENT TO SIDEWALK  
AND CURB.

EXCAVATE ENTIRE  
TREE WELL AREA

HOLES DUG FOR PLANTING OF TREES SHALL BE A MINIMUM OF  
24" LARGER IN DIAMETER THAN THE DIAMETER OF THE ROOT  
SYSTEM. THE BOTTOM OF THE PLANTING HOLE SHALL BE EITHER  
UNDISTURBED SOIL OR 3" OF WELL COMPACTED BACKFILL TO  
REDUCE SETTLING.



APPROVED BY: \_\_\_\_\_ DATE: \_\_\_\_\_

PUBLIC SERVICES DIRECTOR R.C.E. 23797

CITY OF MARTINEZ

TREE PLANTING  
DETAIL

SCALE: NONE  
STD. DRWG.  
NO.  
L-1

SHEET 1 OF 2

## NOTES:

1. TREES SHALL BE PLANTED IN THE CENTER OF THE TREE WELL. PLANT MATERIALS SHALL MEET OR EXCEED STANDARDS OF THE AMERICAN NURSERYMEN ASSOCIATION. ALL EXCAVATED PLANTING HOLES SHALL HAVE VERTICAL SIDES AND FLAT BOTTOMS.
2. IT IS DESIRABLE TO BACKFILL TREES WITH SAME SOIL THAT WAS EXCAVATED. IF THE NATIVE SOIL IS EXTREMELY POOR FOR PLANT GROWTH, AS DETERMINED BY THE CITY PARKS MAINTENANCE SUPERINTENDANT, TOPSOIL SHALL BE SUBSTITUTED AND/OR SOIL AMENDMENTS ADDED TO THE BACKFILL.
3. PRIOR TO PLANTING, ALL ROOT SYSTEMS OF BARE ROOT TREES SHALL BE PROTECTED AGAINST DRYING OUT. ALL DAMAGED ROOTS SHALL BE PRUNED BY CLEANLY CUTTING.
4. TREE FERTILIZER TABLETS SHALL BE ADDED TO THE BACKFILL AS RECOMMENDED BY THE TABLET MANUFACTURER.
5. ROOT DEFLECTORS SHALL BE USED WHENEVER A TREE IS PLANTED ADJACENT TO SIDEWALK, DRIVEWAY OR CURB, TO PREVENT AND REDUCE SURFACE DAMAGE. ROOT SHIELDS ARE USUALLY PLASTIC, CONE SHAPED TO HELP DEFLECT TREE ROOTS DOWNWARD AND PREVENT GIRDLING AND SHALL BE APPROVED BY THE CITY.
6. ROOT BARRIERS SUCH AS A VERTICAL OBSTRUCTION OR A HERBICIDE IMPREGNATED BIO BARRIER FABRIC MAY BE USED WITH OR IN LIEU OF ROOT SHIELDS UPON APPROVAL BY THE CITY.  
A CHEMICALLY IMPREGNATED BARRIER RETARDS ROOT GROWTH (CELL DIVISION) UPON CONTACT. THE CHEMICALS USED ARE NOT ABSORBED BY THE TREE AND AS A RESULT THE IMPREGNATED BARRIER IS NON-TOXIC TO FLORA AND FAUNA.
7. THE BARRIER FABRIC SHALL BE WRAPPED AROUND EXPOSED UTILITY PIPES TO DEFLECT ROOT GROWTH.
8. TREES SHALL BE PLANTED NO DEEPER THAN PREVIOUSLY GROWN WITH SLIGHT ALLOWNACE FOR SETTLING. GRADES OF PLANTING AREAS AFTER SETTLEMENT SHOULD BE ONE INCH BELOW ADJACENT PAVEMENT, SIDEWALK OR TOPS OF CURBS, OTHERWISE IT SHOULD BE ONE INCH ABOVE ADJACENT GROUND.
9. ALL NEWLY PLANTED TREES SHALL BE PRUNED AS NEEDED PRIOR TO PLANTING. ALL POTENTIAL DOUBLE LEADERS, BROKEN BRANCHES, CROWDED BRANCHES AND LOW BRANCHES SHALL BE REMOVED BELOW THE CROWN. ALL PRUNING ON NEWLY PLANTED TREES SHALL BE PERFORMED ACCORDING TO THE NATIONAL ARBORIST ASSOCIATIONS' TREE PRUNING STANDARDS.



APPROVED BY:                      DATE:

\_\_\_\_\_  
PUBLIC SERVICES DIRECTOR R.C.E. 23797

CITY OF MARTINEZ

TREE PLANTING  
DETAIL

SCALE: NONE  
STD. DRWG.

NO.  
L-1

SHEET 2 OF 2

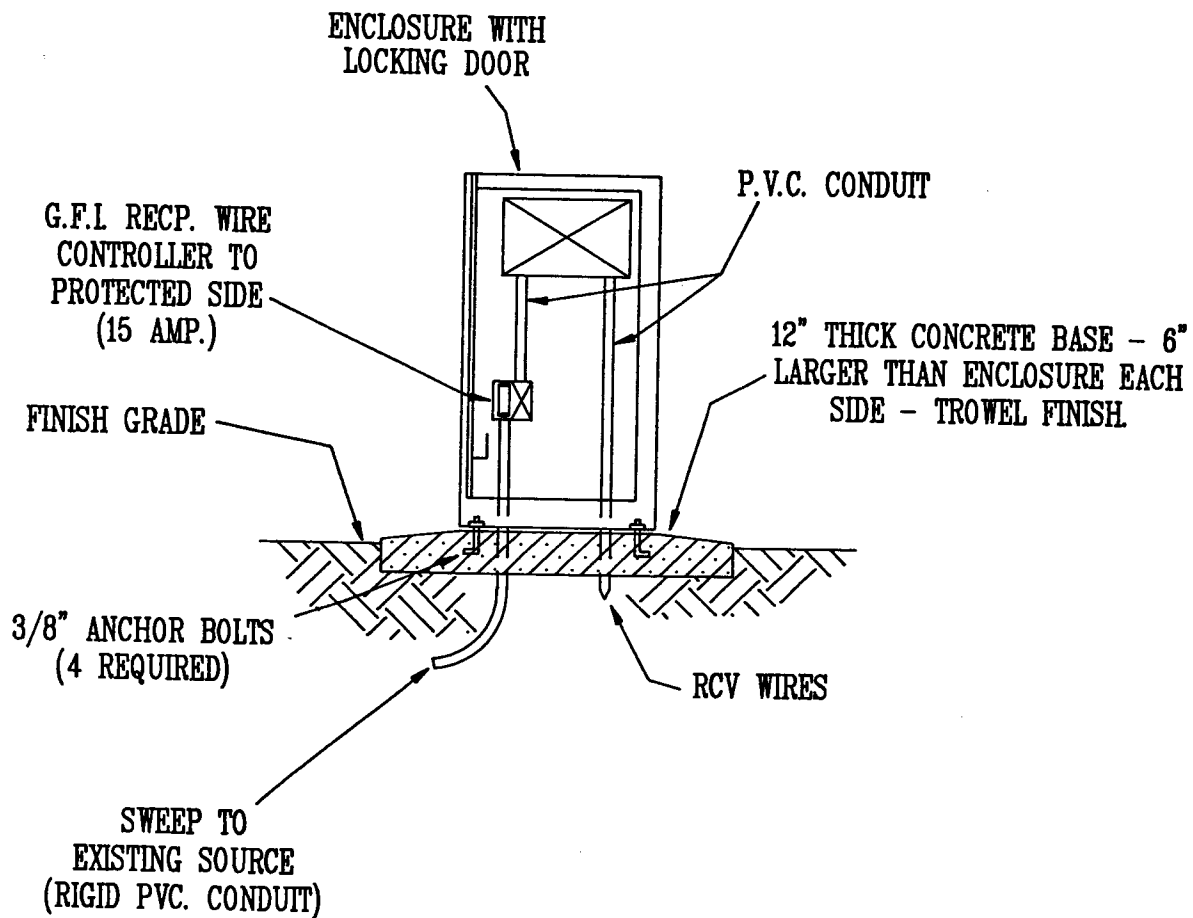

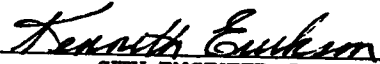
	APPROVED BY:	DATE: 12/22/93	CITY OF MARTINEZ	SCALE: NONE
	 CITY ENGINEER, R.C.E. 13456		MEDIAN CONTROLLER ENCLOSURE	STD. DRWG. NO. 1-1
				SHEET 1 OF 1

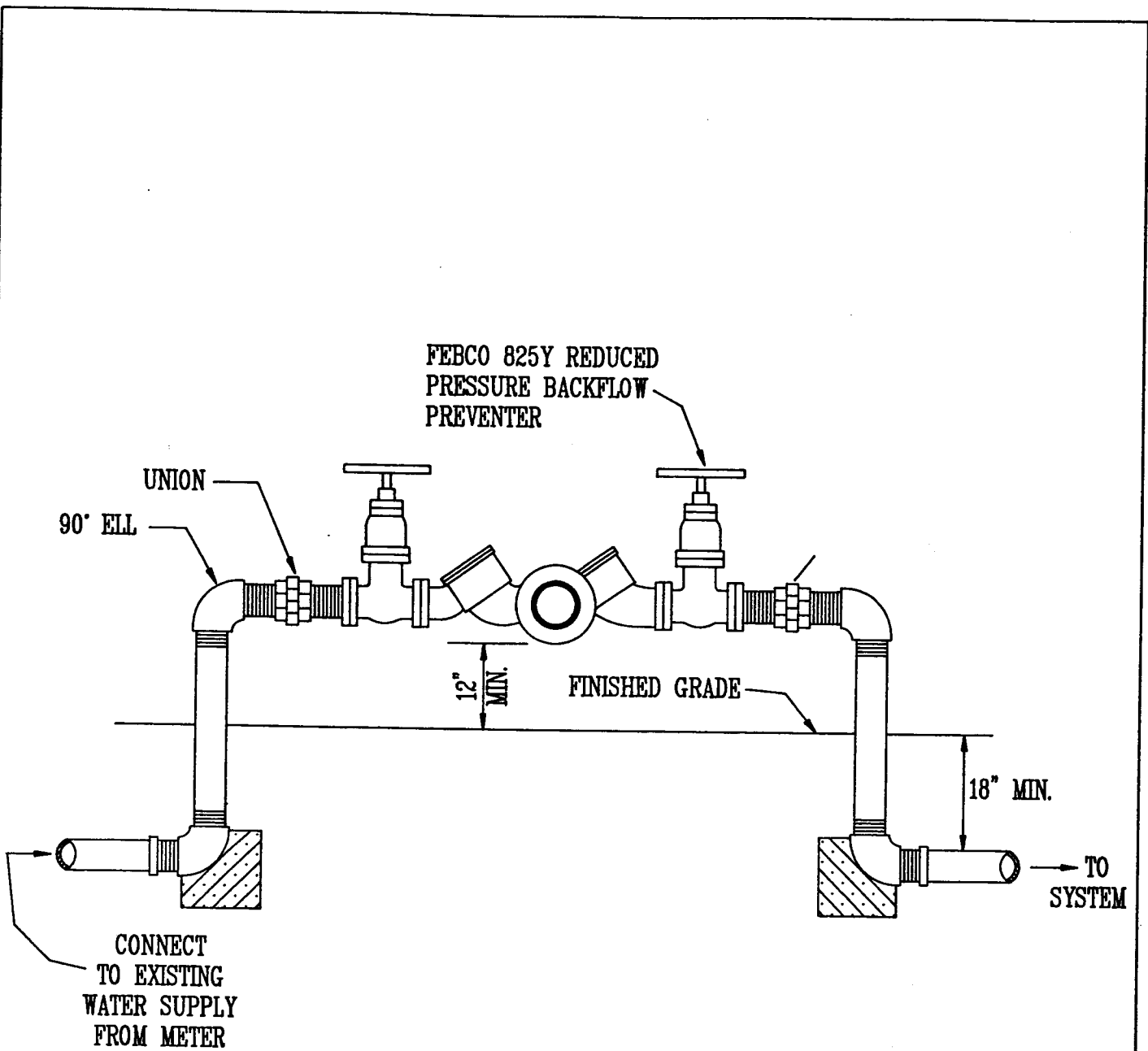

NOTES:

1. SEE STANDARD DRAWING W - 19.
2. THERE SHALL BE NO SECONDARY CONNECTIONS BETWEEN THE METER AND THIS BACKFLOW PREVENTOR DEVICE.
3. ABOVE GROUND ALL BRASS.

	APPROVED BY:	DATE: 12/22/93	CITY OF MARTINEZ	SCALE: NONE
	 CITY ENGINEER, R.C.E. 13456		REDUCED PRESSURE BACKFLOW	STD. DRWG. NO. 1-2
				SHEET 1 OF 1

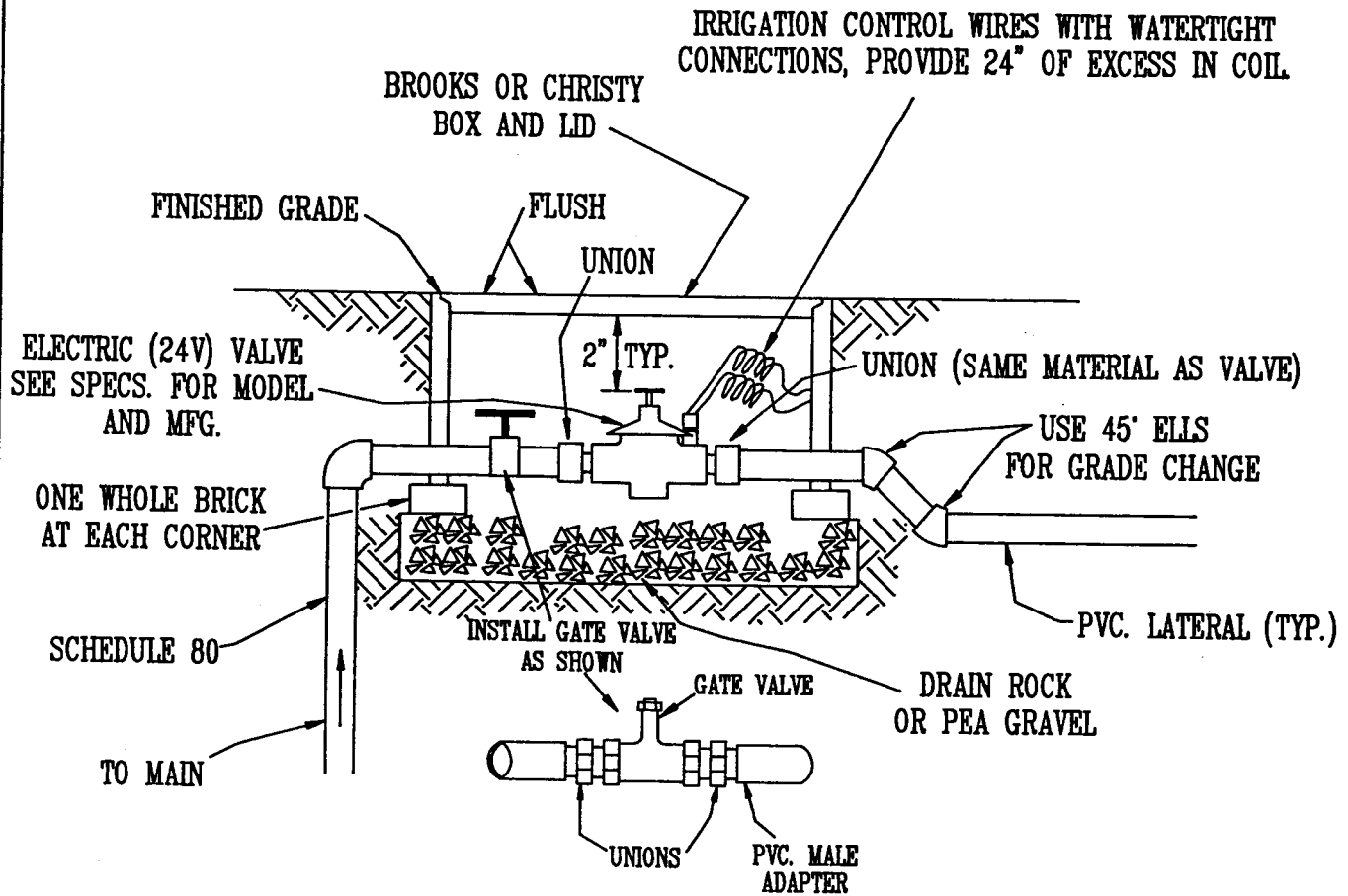

NOTES:

1. ONE VALVE PER BOX, NO DEBRIS OR SOIL INSIDE BOX. FINISH GRADE INSIDE AND OUTSIDE BOX AS SHOWN.
2. VALVE SHALL BE RAINBIRD EFA SERIES OR APPROVED EQUAL. ALL VALVES TO BE EQUIPPED WITH FLOW CONTROL AND WING NUT PET COCK (MANUAL BLEED).
3. ALL THREADED PVC. PIPE AND FITTINGS TO BE SCHEDULE 40 UNDERGROUND, WITH SCHEDULE 80 MATERIAL USED INSIDE BOX.
4. BOX SHALL NOT REST UPON OR TOUCH VALVE OR LATERAL AT ANY POINT.

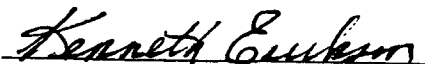
	APPROVED BY:	DATE: 12/22/93	CITY OF MARTINEZ	SCALE: NONE	
	 CITY ENGINEER, R.C.E. 13456			REMOTE CONTROL VALVE	STD. DRWG. NO. 1-3
				SHEET 1 OF 1	

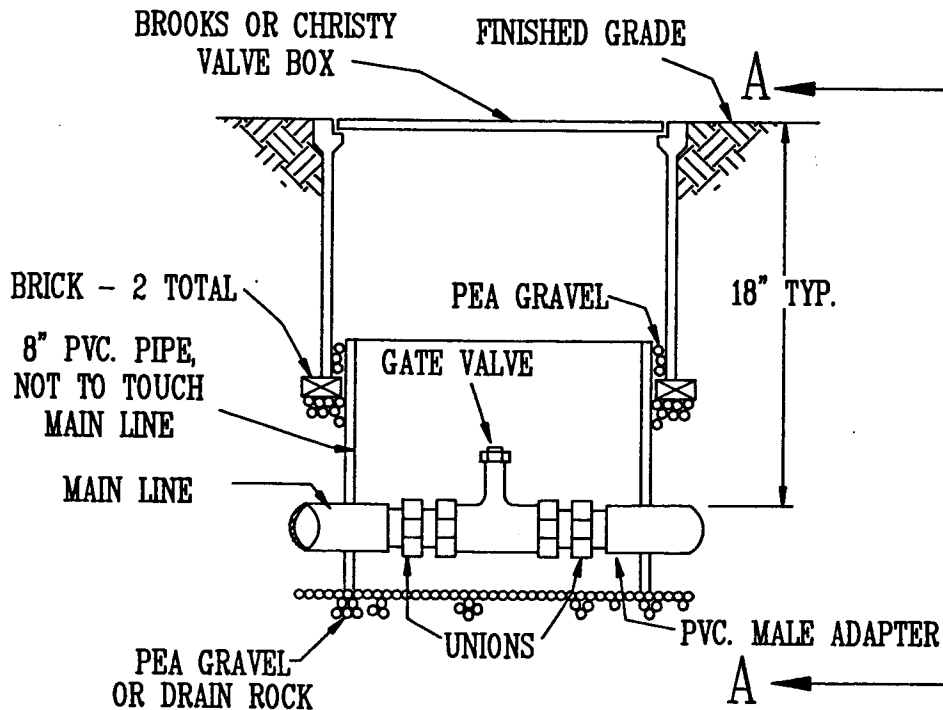
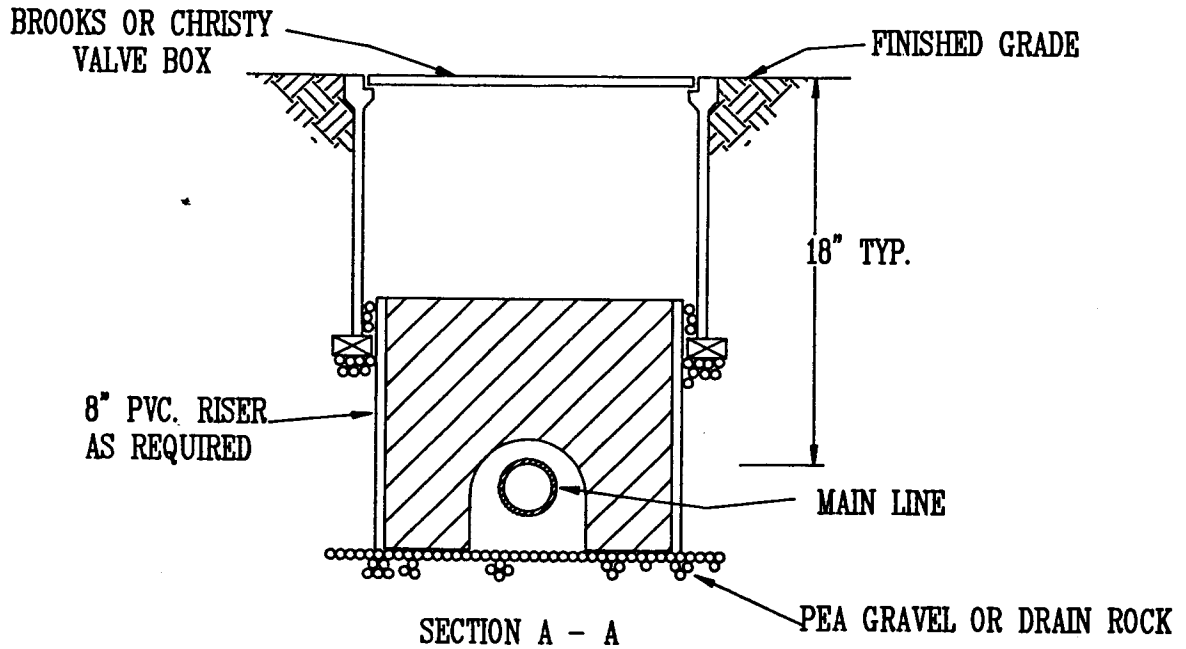

NOTES:

1. INSTALL VALVE ON MAIN LINE BEFORE EACH GROUP OF VALVES TO FACILITATE EASE OF MAINTENANCE TO VALVES.
2. INSTALL PVC. UNIONS ON BOTH SIDES OF GATE VALVE.

	APPROVED BY: <i>Kenneth Erickson</i> CITY ENGINEER, R.C.E. 13456	DATE: 12/22/93	CITY OF MARTINEZ	SCALE: NONE
	GATE VALVE			STD. DRWG. NO. <b>1-4</b>
				SHEET 1 OF 1

WATER FILTER:  
 J - M 25 OZ. HOUSING  
 WITH STAINLESS STEEL FILTER  
 CARTRIDGE SS - 150 MESH  
 OR APPROVED EQUAL.

PVC. LATERAL FROM  
 SOLENOID CONTROL VALVE

MALE ADAPTER  
 PVC. TYP. S X T

PRESSURE REGULATOR  
 SET TO 50 P.S.I  
 DISCHARGE

PVC. NIPPLES  
 AND ELBOWS

INSTALL ONE FULL  
 BRICK AT EACH CORNER

PRESSURE GAUGES

LATERAL PVC. TO  
 EMITTER PIPING

PROVIDE 4" LAYER OF  
 3/4" DRAIN ROCK OR PEA  
 GRAVEL IN BOTTOM OF BOX

CONCRETE BOX WITH BOLT DOWN  
 12" X 22" LID; LID TO BE  
 MARKED "IRRIGATION" OR BLANK.

NOTES:

1. ALL THREADED PVC. PIPE AND FITTINGS TO BE SCHEDULE 40 UNDERGROUND, WITH SCHEDULE 80 MATERIAL USED INSIDE BOX.
2. IN ADDITION TO ILLUSTRATED ASSEMBLY PROVIDE SOLENOID CONTROL VALVE ASSEMBLY.
3. CONSTRUCT ALL EQUIPMENT WITH MINIMUM 2" CLEARANCE TO SIDES, BOTTOM, AND LID.

	APPROVED BY:      DATE: 12/22/93	CITY OF MARTINEZ	SCALE: NONE
	<i>Kenneth Eubank</i>	DRIP SYSTEM FILTER ASSEMBLY	STD. DRWG. NO. <b>1-5</b>
	CITY ENGINEER, R.C.E. 13456		SHEET 1 OF 1



**QUICK COUPLING VALVE  
( RAINBIRD #44 WITH LOCKING  
VINYL CAP )**

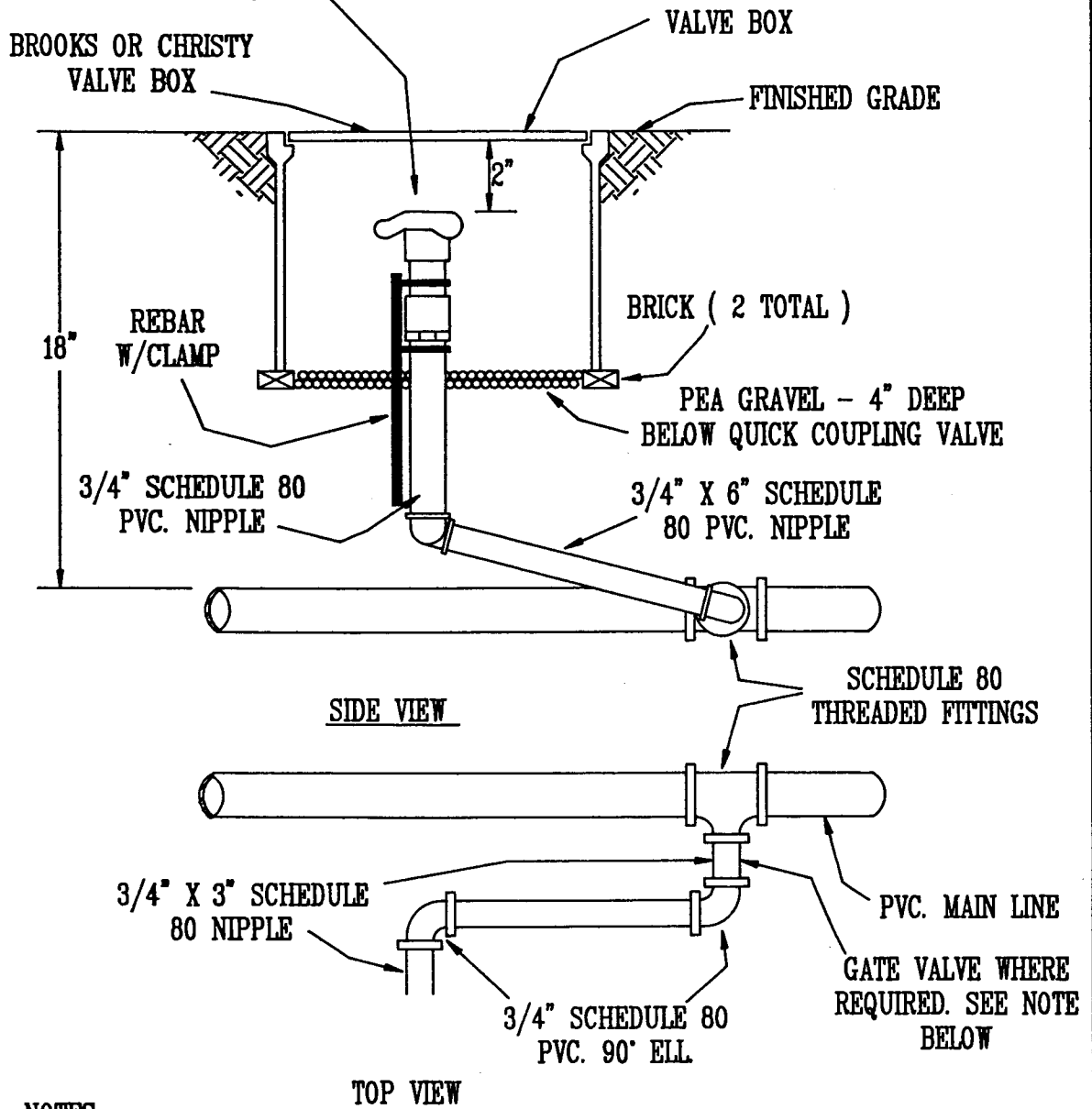

**NOTES:**

1. VALVE BOX SHALL HAVE A LOCK BOLT.
2. INSTALL REBAR 18" LONG WITH 2 CLAMPS AS SHOWN.
3. GATE VALVE TO BE INSTALLED PER GATE VALVE STANDARD DRAWING WHEN QUICK COUPLER IS LOCATED IN A BALLFIELD AREA OR AS DETERMINED BY THE CITY.
4. ALL FITTINGS & NIPPLES TO BE THREADED.

APPROVED BY:  CITY ENGINEER, R.C.E. 13456	DATE: 12/22/93	CITY OF MARTINEZ	SCALE: NONE STD. DRWG.
		QUICK COUPLING VALVE	NO. <b>1-6</b> SHEET 1 OF 1

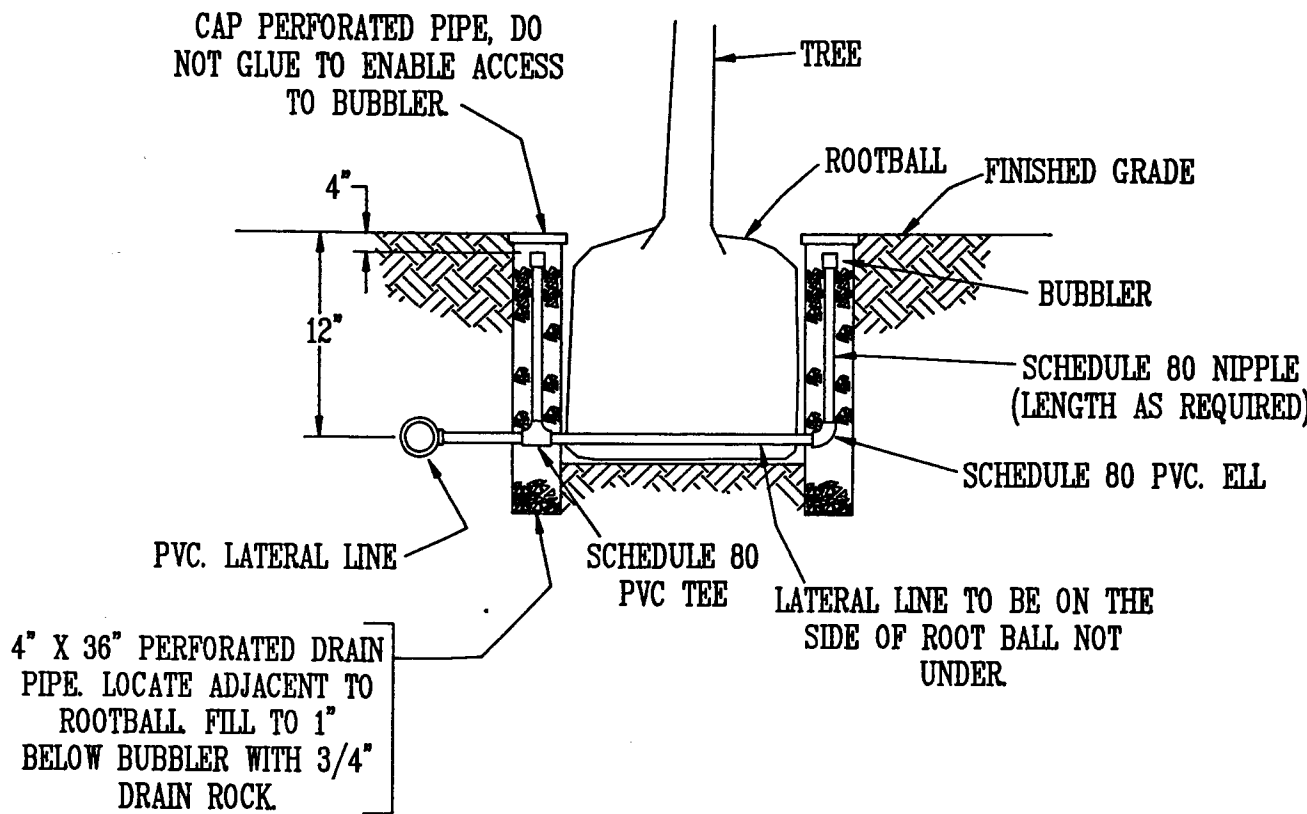

- NOTES:
1. BUBBLERS FOR TREES IN LAWN. TWO BUBBLERS PER TREE TO BE PLACED ON OPPOSITE SIDES OF ROOTBALL.
  2. SEE STANDARD DRAWING L - 1 FOR PLUMBING DETAIL.

APPROVED BY: <i>Kenneth Cochran</i> CITY ENGINEER, R.C.E. 13456	DATE: 12/22/93	CITY OF MARTINEZ	SCALE: NONE
		BUBBLER AT LAWN TREES & STREET TREES	STD. DRWG. NO. <b>1-7</b>
			SHEET 1 OF 1

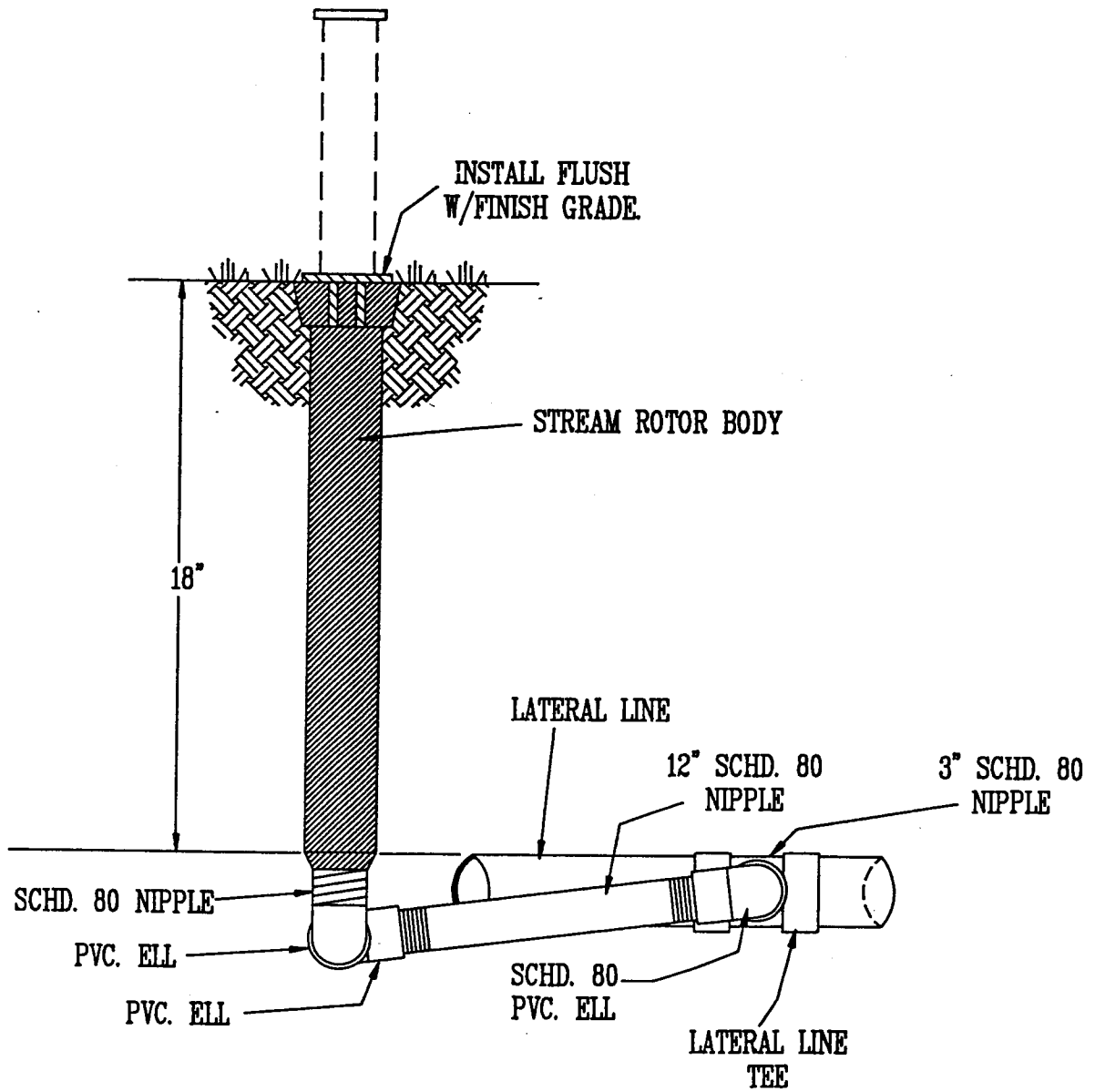

APPROVED BY: <i>Kenneth E. Eichen</i> CITY ENGINEER, R.C.E. 13456	DATE: 12/22/93	CITY OF MARTINEZ	SCALE: NONE
	STREAM ROTOR POP - UP	STD. DRWG. NO. <b>1-8</b>	SHEET 1 OF 1

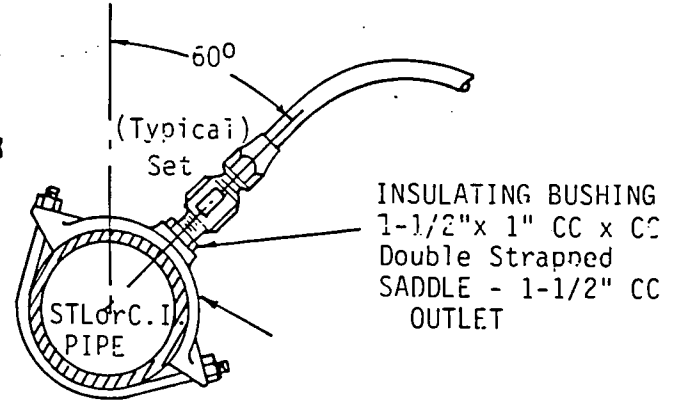
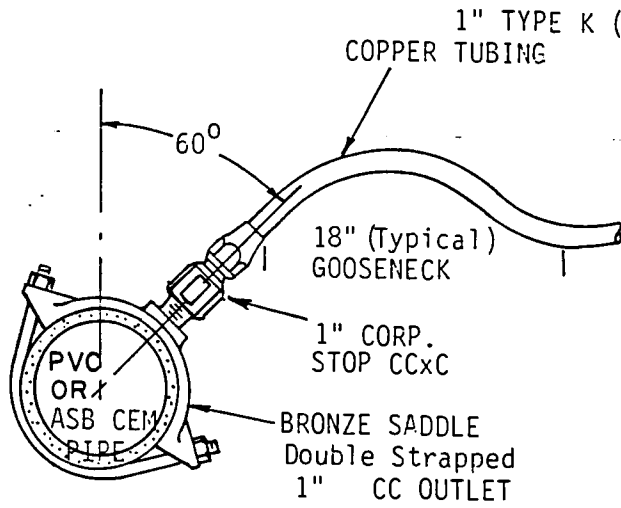

1" SERVICE WITH SADDLE

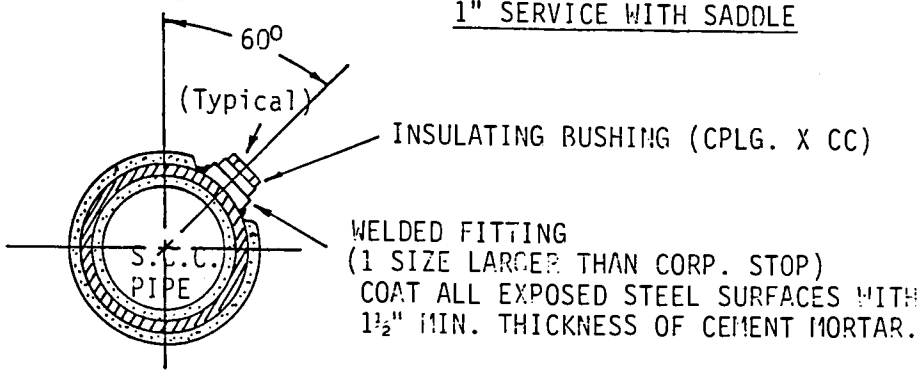

1"- 2" SERVICE TO STEEL MAIN

SERVICE LINES
ALL SERVICE LINES SHALL BE 1", 2", 4", etc. DIAMETER PIPING WITH INTERMEDIATE SIZES NOT PERMITTED.
5/8" - 1" Meters use 1" copper
1 1/2" - 2" Meters use 2" copper
4" Meters use 4" ductile iron
5" Meters and above use pipe conforming to Water Specs.

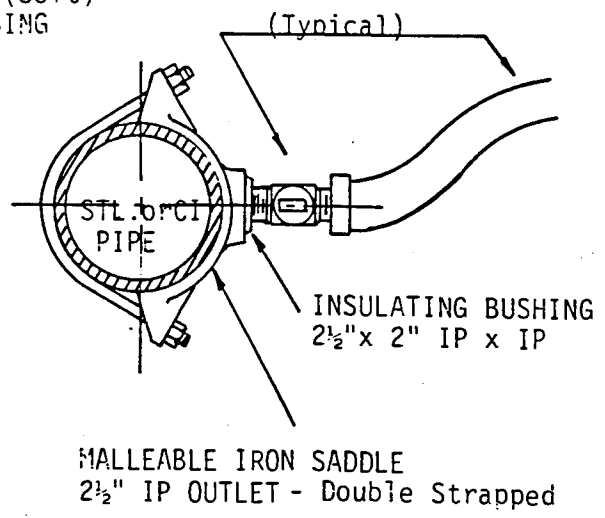
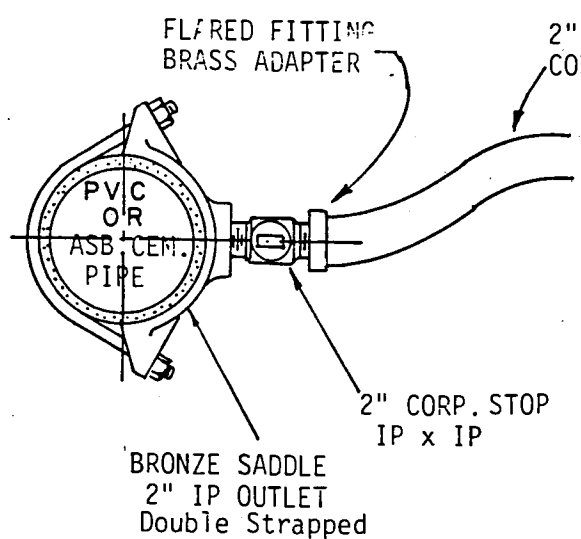

2" SERVICE

ENCASE ALL MALLEABLE IRON OR STEEL WITH POLYETHYLENE.

	REV.	APP.	DATE	DESCRIPTION	<p>CITY OF MARTINEZ PUBLIC WORKS DEPARTMENT</p> <p>STANDARD DETAIL</p> <p>SERVICE CONNECTIONS</p>	<p>SCALE: STD. DRWG. NO. <b>W-1</b></p> <p>SHEET <u>1</u> OF <u>1</u></p>
	DRAWN BY: <i>A. Rocha</i>		CHECKED BY:			
	APPROVED BY: <i>R.P. Cullen</i>		DATE: <i>23797 12/22/88</i>			
	CITY ENGINEER, R.C.E.		DATE:			

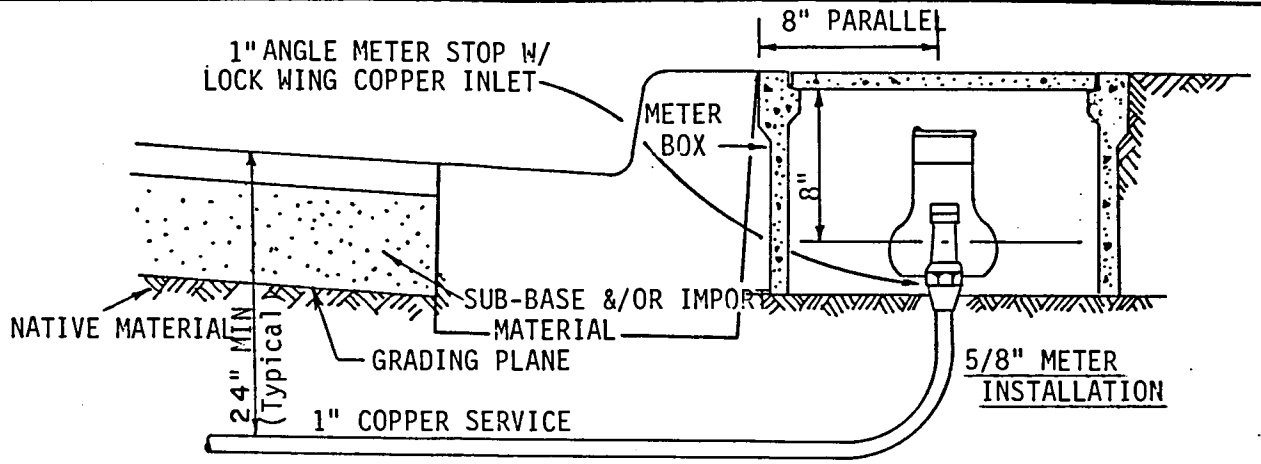

**METER BOX LOCATION**

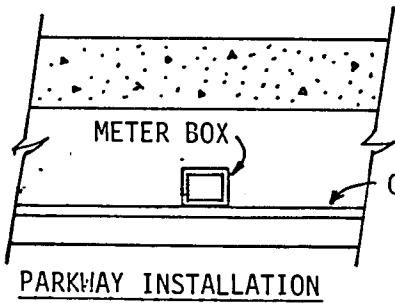

1" ANGLE METER STOP W/ LOCK WING COPPER INLET

Curbface (Typical)

PARKWAY INSTALLATION

1" COPPER SERVICE

1" METER INSTALLATION

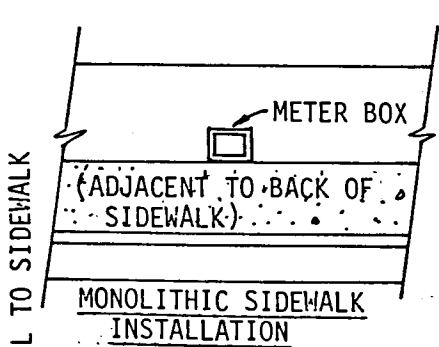

PARALLEL TO SIDEWALK

Set box on 6" (min.) crushed rock for drainage. (Typical)

COMMERCIAL SIDEWALK INSTALLATION

2" ANGLE METER STOP WITH LOCK WING - INSIDE IP INLET

2" BRASS PIPE

2" BRASS STREET ELL

FLARED COUPLING - INSIDE I.P. BRASS ADAPTER.

2" COPPER SERVICE

2" METER INSTALLATION

NOTE: ONLY FLARED COUPLINGS SHALL BE USED ON ALL SIZES OF COPPER SERVICE LINES.

- NOTE: - CURB STOP SHALL BE MUELLER H10257 WITH MUELLER H15530 QUARTER BEND COUPLING.
- ANGLE STOP SHALL BE MUELLER H14275.
- UNLESS OTHERWISE APPROVED BY ENGINEER.
- METER BOXES SHALL BE PARALLEL TO SIDEWALK.

5/8" METER CHRISTY BOX NO. B9	8" PAR.	8" DEEP
1" " " " " B16	8" " "	8" " "
1-1/2" " " " " B30	9" " "	9" " "
2" " " " " B36	12" " "	9" " "

ALL LIDS EXCEPT B-9, WITH READING LIDS



REV.	APP.	DATE	DESCRIPTION
DRAWN BY: <i>A. 2004</i>		CHECKED BY:	
APPROVED BY: <i>R.P. Cullen</i>		DATE: <i>12/22/88</i>	
CITY ENGINEER, R.C.E.		DATE	

CITY OF MARTINEZ  
PUBLIC WORKS DEPARTMENT

STANDARD DETAIL  
5/8" TO 2"  
METER INSTALLATIONS

SCALE:  
STD. DRWG.  
NO.  
**W-2**  
SHEET 1 OF 1

OK 12.14.83 RRC

PLAN

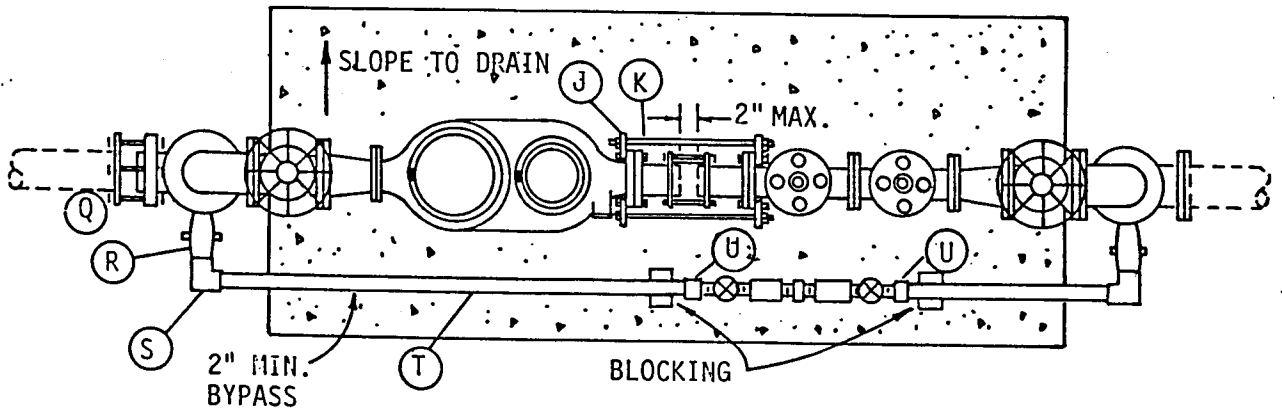

PROFILE

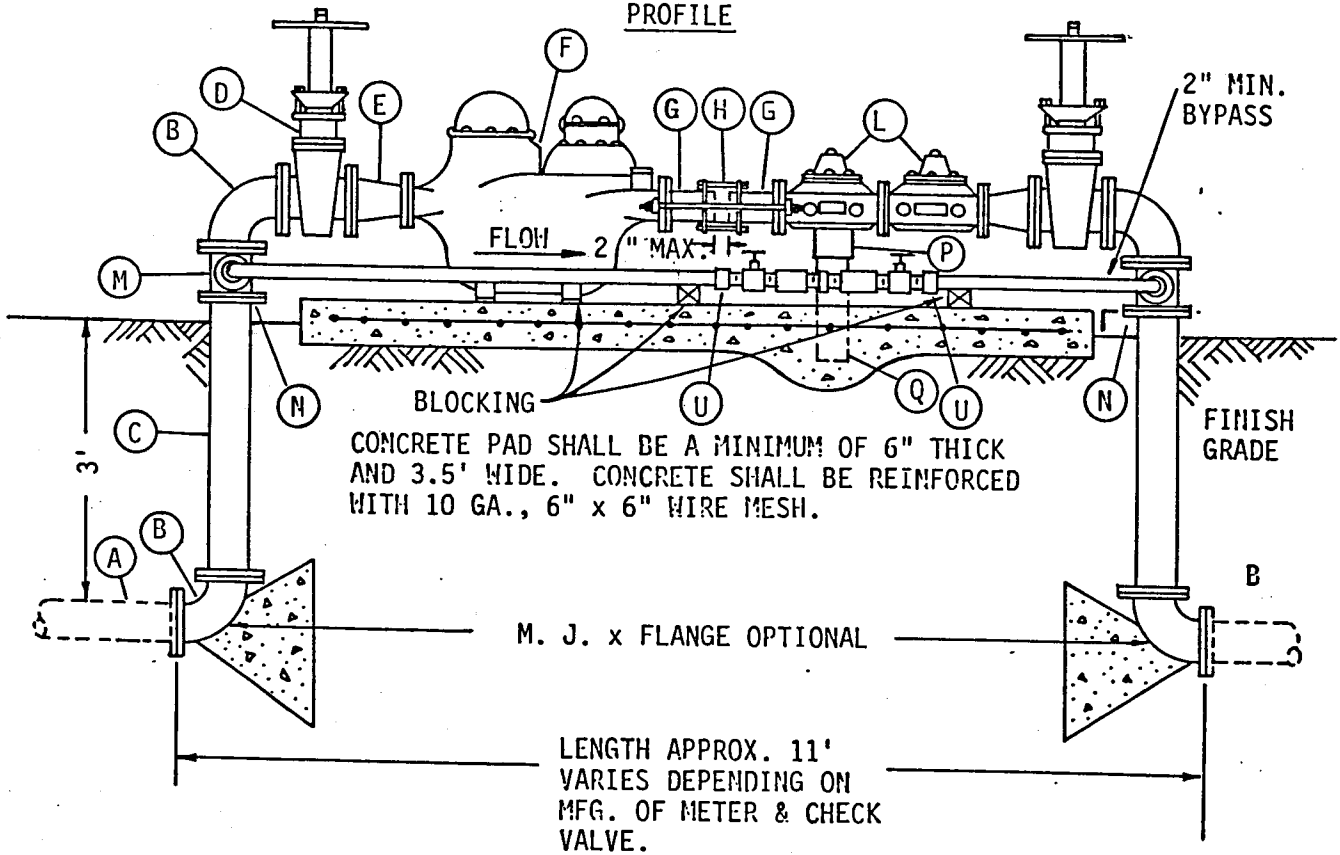

OK 12.14.83 RRC

	REV.	APP.	DATE	DESCRIPTION	CITY OF MARTINEZ PUBLIC WORKS DEPARTMENT  <b>3" COMPOUND METER</b>  ASSEMBLY ABOVE GROUND	SCALE:
	DRAWN BY: A. POCHA			CHECKED BY:		STD. DRWG. NO.
	APPROVED BY:					<b>W-3</b>
	J. J. Cullen 23797 12/22/80 CITY ENGINEER, R.C.E.			DATE:		

LIST OF MATERIAL

ITEM	QTY.	DESCRIPTION
		SERVICE
A	1	4" DUCTILE IRON
B	4	4" ELL 90° FLG.
C	2	4" C.I., PIPE F.B.E.
D	1	4" GATE VALVE FLG.
E	1	4" x 3" REDUCER FLG.
F	1	3" COMPOUND METER
G	2	3" C.I. PIPE F.O.E. (6" LONG)
H	1	3" FLEX CPLG. C.I.
J	4	DUK LUG
K	2	5/8" Ø TIE ROD S./S. (21" LONG) CUT TO FIT
M	2	4" x 4" x 4" FLANGED TEE WITH FLANGED REDUCER
N	2	2 1/2" x 2" NYLON BUSHING
P	1	4" CPLG. S.S. GALV.
Q	1	4" GALV. PIPE T.O.E. (18" LONG)
R	2	2" CORP COCK I.P. - (MIN.)
S	2	2" ELL 90° K x I.P. FE. - SL. (MIN.)
T	12'	2" COPPER TUBING (MIN.)
	7	4" FLG. HARDWARE SET
	2	3" FLG. HARDWARE SET
U	4	2" MIN. METER FLANGE
DOUBLE CHECK VALVE ASS'Y		
D	1	4" GATE VALVE FLG.
E	1	4" x 3" REDUCER FLG.
L	2	3" CHECK VALVE FLG (APPROVED STYLE)
	1	4" FLG. HARDWARE SET
	3	3" FLG. HARDWARE SET

NOTES:

- ASS'Y SHALL HAVE AN ENCLOSURE THAT IS MINIMUM 5' HIGH x 4' WIDE x 13' LONG AND 18" MIN. INSIDE CLEARANCE; WITH A REMOVEABLE TOP AND A 3' WIDE LOCKABLE GATE. DETAILS TO BE APPROVED BY CITY.
- USE INSULATION KIT BETWEEN ALL DISSIMILAR METALS.

OK PRC 12.19.83

	REV.	APP.	DATE	DESCRIPTION	CITY OF MARTINEZ PUBLIC WORKS DEPARTMENT  3" COMPOUND METER  ASSEMBLY ABOVE GROUND	SCALE:
	DRAWN BY: <i>A. Rocha</i>			CHECKED BY:		STD. DRWG. NO. <b>W-3</b>
	APPROVED BY: <i>R.P. Cullen</i>			DATE: <i>12/22/88</i>		
	CITY ENGINEER, R.C.E.			DATE:		

PLAN

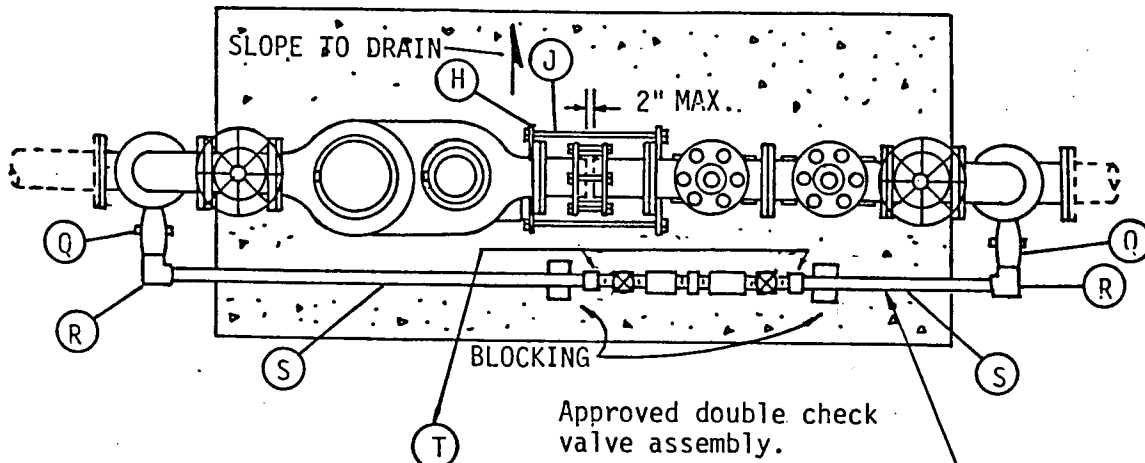

PROFILE

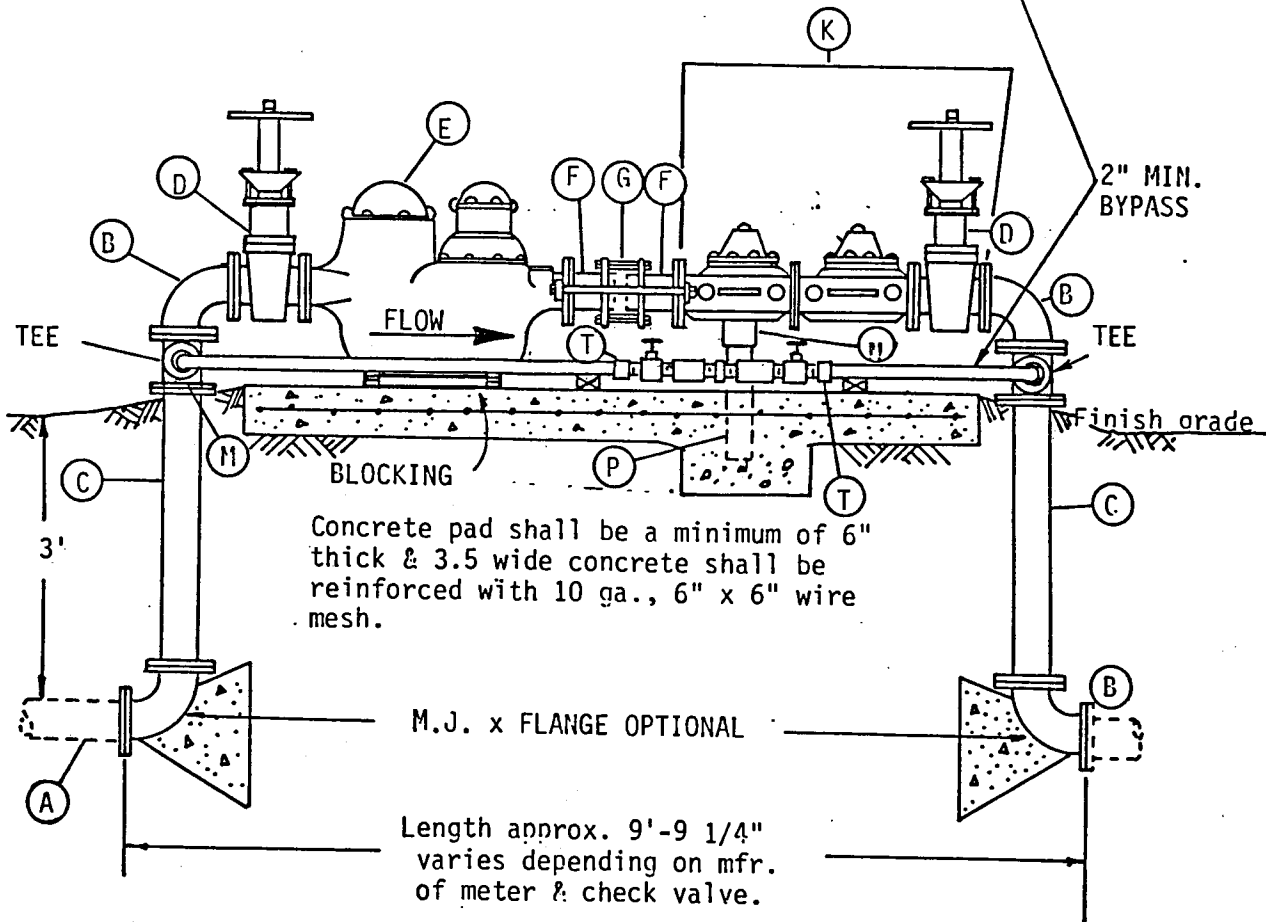

OK 12.19.83 RRC

	REV. APP. DATE DESCRIPTION DRAWN BY: <i>A. Rocca</i> CHECKED BY: APPROVED BY: <i>R.P. Cullen</i> 23797 12/22/82 CITY ENGINEER, R.G.E. DATE:	CITY OF MARTINEZ PUBLIC WORKS DEPARTMENT 4" COMPOUND METER & BACKFLOW PREVENTION DEVICE ABOVE GROUND	SCALE: STD. DRWG. NO. <b>W-4</b> SHEET 1 OF 2



LIST OF MATERIAL

Item	Qty	Description
A	1	DUCTILE IRON
B	4	4" ELL 90°
C	2	4" C.I. PIPE F.B.E.
D	1	4" GATE VALVE FLG.
E	1	4" COMPOUND METER
F	2	4" C.I. PIPE F.O.E. (6" LONG)
G	1	4" FLEX. CPLG. C.I.
H	4	DUC LUG
J	2	5/8" Ø TIE ROD S.S. (21" LONG) CUT TO FIT.
L	2	4" x 4" x 4" FLANGED TEE WITH FLANGED RED.
M	2	4" x 4" x 2½" TEE
N	1	4" CPLG. S.S. GALV.
P	1	4" TREADED PIPE GALVANIZED
Q	2	2" CORP. COCK I.P. (LOCKABLE) (MIN.)
R	2	2" ELL 90° K x I.P. FE.-SL. (MIN.)
S	12'	2" COPPER TUBING (MIN.)
T	8	4" FLG. HARDWARE SET
	4	2" BRASS METER FLANGES (MIN.)
		DOUBLE CHECK VALVE ASS'Y
D	1	4" GATE VALVE FLG.
K	1	4" CHECK VALVE ASSEMBLY APPROVED

NOTES:

1. ASS'Y SHALL HAVE AN ENCLOSURE THAT IS MINIMUM 5' HIGH x 4' WIDE x 13' LONG AND 18" MINIMUM INSIDE CLEARANCES WITH A REMOVABLE TOP AND A 3' WIDE LOCKABLE GATE. DETAILS TO BE APPROVED BY CITY.
2. USE INSULATION KIT BETWEEN ALL DISSIMILAR METALS.

C-2 12.14.83  
RRC

	REV.	APP.	DATE	DESCRIPTION	CITY OF MARTINEZ PUBLIC WORKS DEPARTMENT 4" COMPOUND METER ASSEMBLY ABOVE GROUND	SCALE:	
	DRAWN BY: <i>A. Fong</i>			CHECKED BY:			STD. DRWG. NO.
	APPROVED BY: <i>R.K. Cullen</i>			DATE: <i>12/22/88</i>			<b>W-4</b>
	CITY ENGINEER, R.C.E.						SHEET 2 OF 2

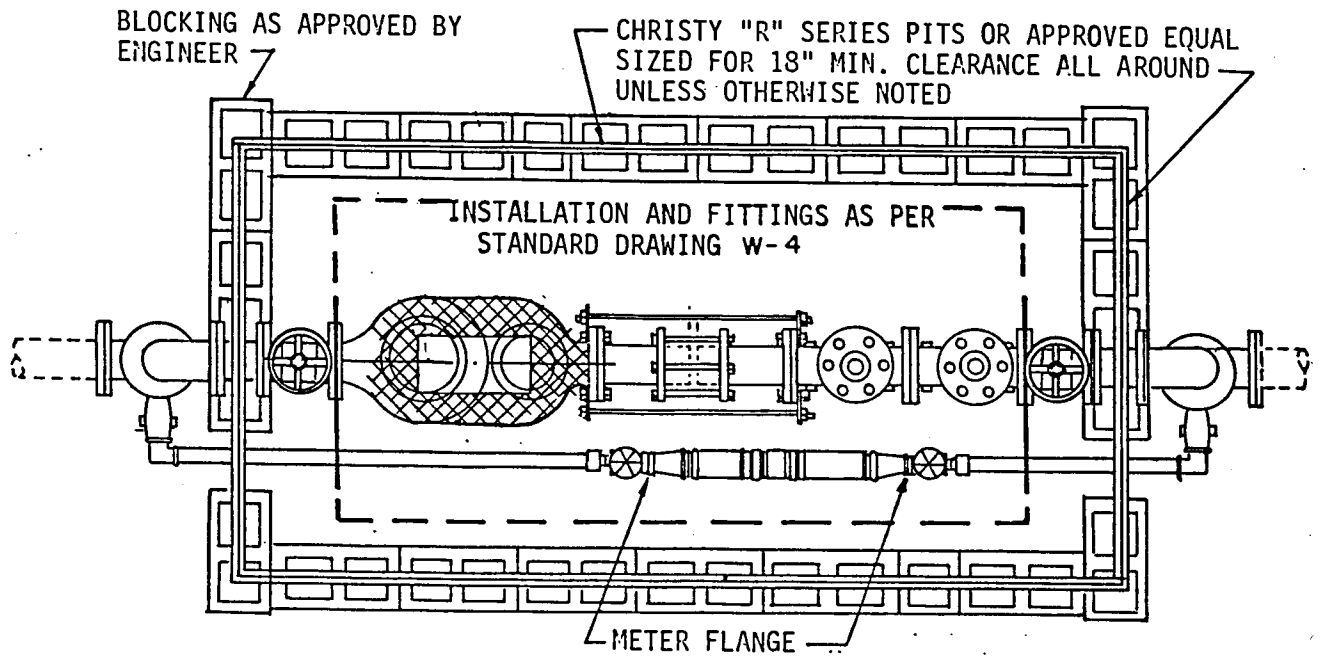

PLAN

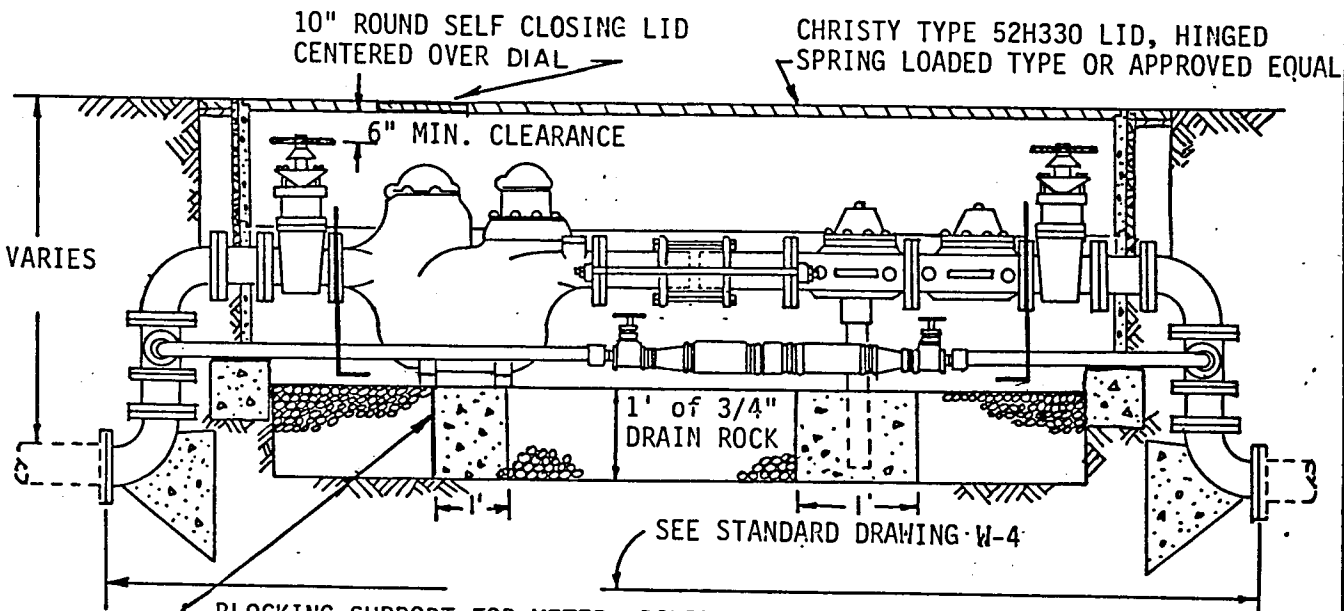

PROFILE

OK RRC  
12.14.83

	REV.	APP.	DATE	DESCRIPTION	<b>CITY OF MARTINEZ</b> <b>PUBLIC WORKS DEPARTMENT</b>	<b>SCALE:</b> <b>STD. DRWG.</b> <b>NO.</b> <b>W-5</b>
	DRAWN BY: <i>A. Rocha</i>			CHECKED BY:		
	APPROVED BY: <i>R.P. Cullen</i>			DATE: <i>12/22/83</i>		
	CITY ENGINEER, R.C.E.					

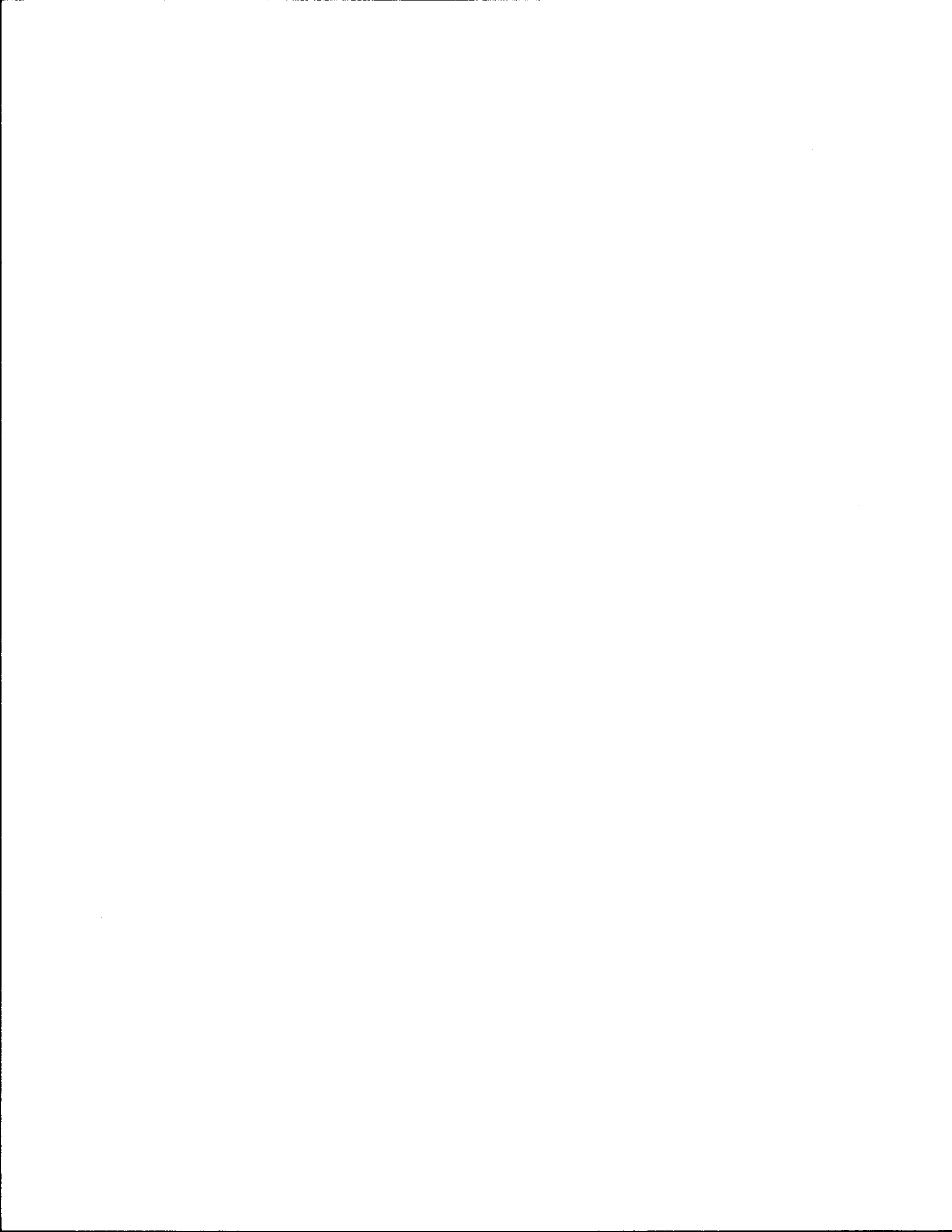

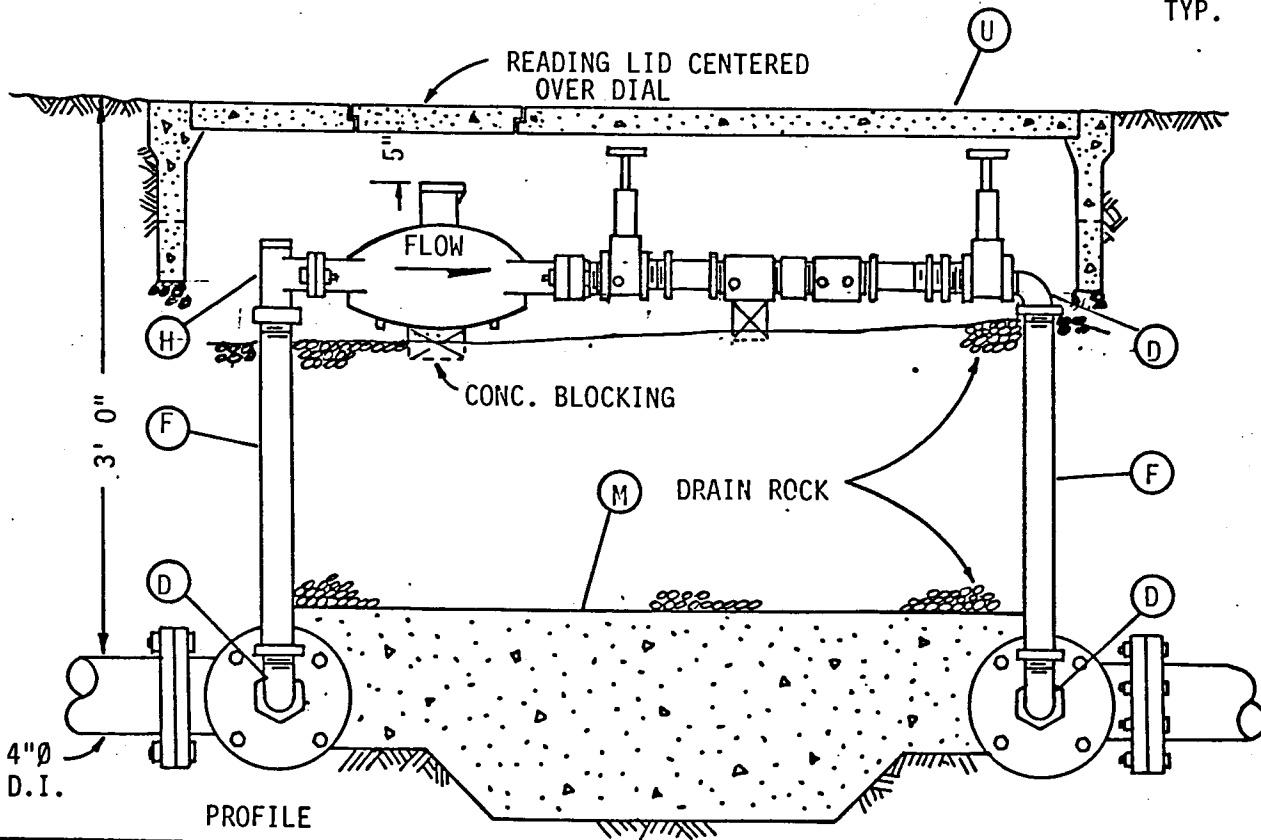
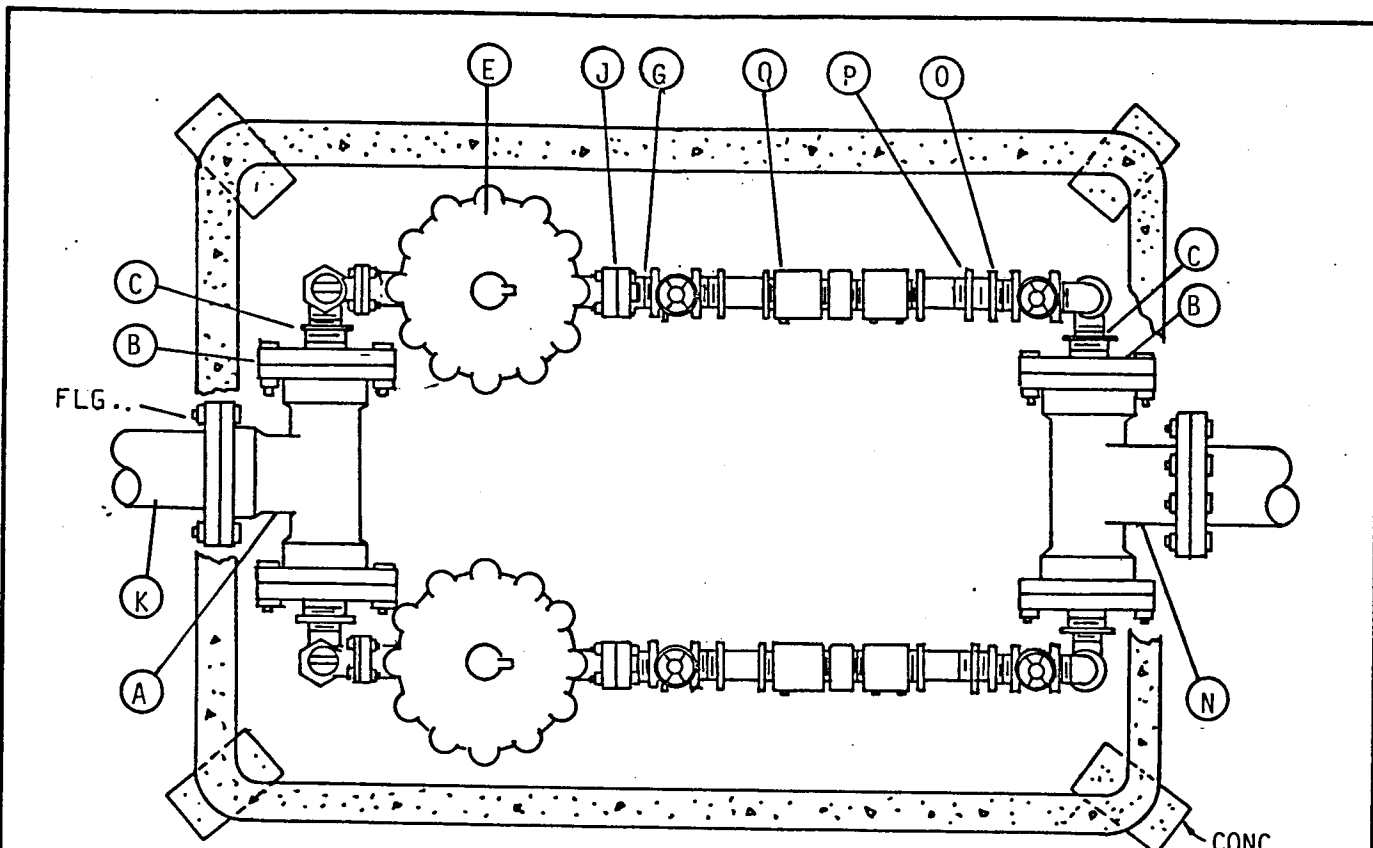

OK 12-14-83  
RRC

	REV. APP. DATE DESCRIPTION DRAWN BY: <i>A. P. Cullen</i> CHECKED BY: APPROVED BY: <i>R. P. Cullen 23797 12/22/83</i> CITY ENGINEER, R.C.E. DATE:	CITY OF MARTINEZ PUBLIC WORKS DEPARTMENT 1 1/2" & DUAL 2" METER INSTALLATION SERVICE	SCALE: STD. DRWG. NO. <b>W-6</b> SHEET 1 OF 2
--	---	---	---

**LIST OF MATERIAL**

ITEM	QTY.	DESCRIPTION
<b>DUAL 2" METER INSTALLATION SERVICE</b>		
A	1	4" TEE M.J.
B	4	4" FLANGED, TAPPED 2-1/2" I.P.
C	4	2-1/2" x 2" NYLON BUSHING
D	6	2" ELL STREET, S.S. BRASS
E	2	2" METER
F	4	2" x 18" NIPPLE, S.S. BRASS
G	2	2" x 6" NIPPLE, S.S. BRASS
H	2	2" ANGLE STOP, I.P. x FLG., BRASS
J	2	2" OVAL FLG., TAPPED 2" I.P.
K	-	4" D.I. PIPE
L	2	NO. 65 METER BOX & COVER
M	-	THRUST BLOCK
N	1	4" TEE M.J. x FLG.
<b>DUAL 1 1/2" METER INSTALLATION SERVICE</b>		
U	1	METER BOX & COVER*
DUAL 1 1/2" METER INSTALLATION SERVICE (-S) (Same as above except substitute the following)		
H'	2	2" BRASS WHEEL VALVES @ BRASS 2" x 1 1/2" BUSHINGS, NIPPLES & FLANGES.
E'	2	1 1/2" METER
G'	2	1 1/2" x 6" NIPPLE, S.S. BRASS
J'	2	1 1/2" OVAL FLANGE
D'	2	2" x 1 1/2" REDUCING STREET ELL
<b>CHECK VALVE (SIZE AS APPROXIMATE)</b>		
Q	2	DOUBLE CHECK VALVE ASSEMBLY
O	4	BRASS METER FLANGE
P	2	BRASS NIPPLES

\* METER BOX AND COVER SHALL BE CHRISTY PRODUCTS OR EQUAL. SIZED FOR MINIMUM 3 INCHES FOR 3 INCH MINIMUM CLEARANCE ALL AROUND, UNLESS NOTED.

OK 12.14.83  
RRC

	REV.	APP.	DATE	DESCRIPTION	CITY OF MARTINEZ PUBLIC WORKS DEPARTMENT  DUAL 1-1/2" & 2" METER INSTALLATION SERVICE	SCALE:
	DRAWN BY: A. Pocha		CHECKED BY:			STD. DRWG. NO.
	APPROVED BY:		DATE:			<b>W-6</b>
	CITY ENGINEER, R.C.E.					SHEET 2 OF 2

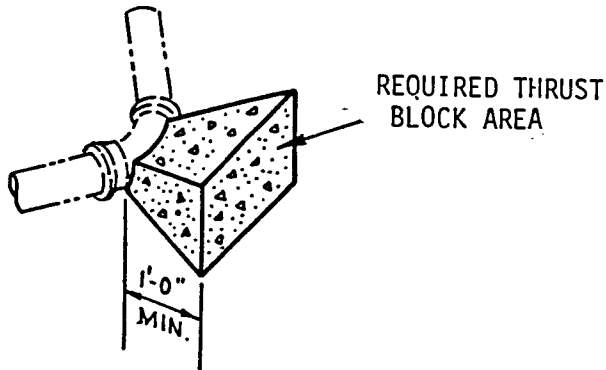

TYPICAL THRUST BLOCK - ELL

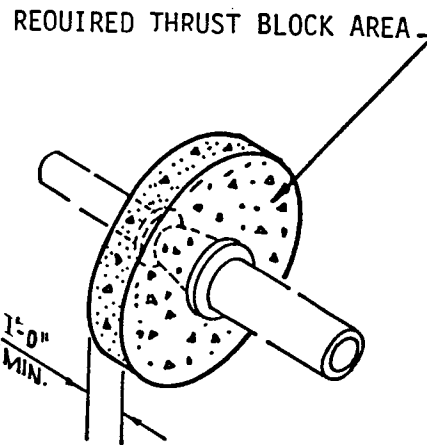

TYPICAL THRUST BLOCK - REDUCER  
AS REQUIRED BY ENGINEER

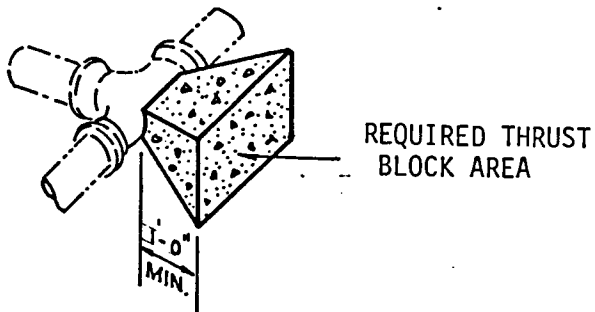

TYPICAL THRUST BLOCK - TEE

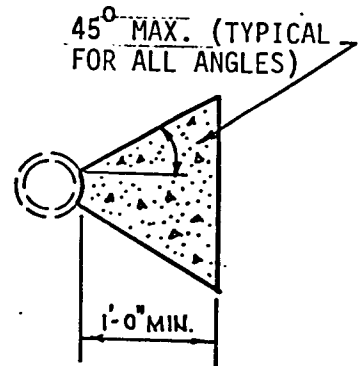

TYPICAL SECTION  
THRU THRUST BLOCK

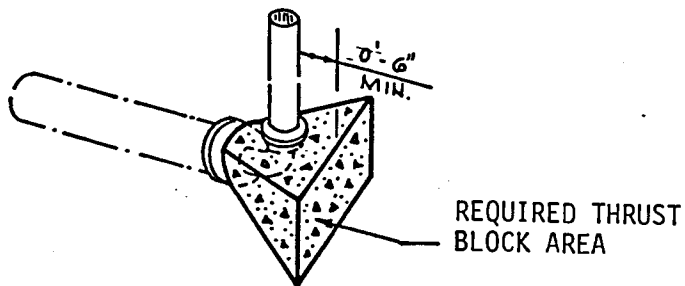

TYPICAL THRUST BLOCK - PERMANENT BLOW-OFF

NOTE: WRAP ALL FITTING PRIOR TO INSTALLING THRUST BLOCK.

*OK 12.14.83 RRC*

	REV.	APP.	DATE	DESCRIPTION	CITY OF MARTINEZ PUBLIC WORKS DEPARTMENT	SCALE:	
	DRAWN BY: A. ROCHA					CHECKED BY:	STD. DRWG. NO.
	APPROVED BY: <i>J.P. Cullen</i>				23797	<b>BLOCKING DETAIL</b>	<b>W-7</b>
	CITY ENGINEER, R.C.E.				DATE: 12/23/88		

RR 12.24.83

TYPICAL THRUST BLOCKS

FITTING	PIPE SIZE (IN)	SOIL TYPE	BEARING AREA (SQ.FT.)	D (FT.)	CONCRETE VOLUME (CU.FT.)	FITTING	PIPE SIZE (IN)	SOIL TYPE	BEARING AREA (SQ.FT.)	D (FT.)	CONCRETE VOLUME (CU.FT.)
22-1/2° ELBOW	6	CLAY OR SAND	10	1.0	6	45° ELBOW	6	CLAY OR SAND	10	1.0	6
	8	CLAY OR SAND	11	1.0	6		8	CLAY OR SAND	11	1.0	6
	10	CLAY OR SAND	11	1.0	7		10	CLAY	14	1.2	11
	12	CLAY OR SAND	12	1.0	9		10	SAND	12	1.0	8
	14	CLAY OR SAND	13	1.0	10		12	CLAY	18	1.5	18
	16	CLAY	16	1.2	14		12	SAND	13	1.0	9
90° ELBOW	16	SAND	14	1.0	11	TEE	14	CLAY	24	1.6	29
	6	CLAY OR SAND	10	1.0	6		14	SAND	14	1.0	11
	8	CLAY	14	1.2	9		16	CLAY	32	2.2	47
	8	SAND	11	1.0	6		16	SAND	17	1.2	16
	10	CLAY	23	1.7	24		6	CLAY OR SAND	10	1.0	6
	10	SAND	14	1.0	10		8	CLAY OR SAND	10	1.0	6
	12	CLAY	33	2.2	46		10	CLAY	17	2.0	19
	12	SAND	16	1.0	12		10	SAND	9	1.2	6
	14	CLAY	45	2.7	77		12	CLAY	23	2.4	32
	14	SAND	24	1.4	25		12	SAND	12	1.4	10
C.I. PLUG	16	CLAY	57	3.1	113	REDUCER	14	CLAY	32	2.6	51
	16	SAND	29	1.5	36		14	SAND	16	1.7	17
	6	CLAY OR SAND	6	1.0	3		16	CLAY	40	3.2	75
	8	CLAY OR SAND	10	1.0	7		16	SAND	21	2.0	27
	10	CLAY	16	1.6	13		16 x 14	CLAY	9		9
	10	SAND	8	1.0	4		16 x 14	SAND	5		5
	12	CLAY	23	2.0	26		16 x 12	CLAY	17		17
	12	SAND	12	1.2	8		16 x 12	SAND	9		9
	14	CLAY	31	2.2	36		14 x 12	CLAY	9		9
	14	SAND	16	1.4	12		14 x 12	SAND	5		5
16	CLAY	40	2.6	57	14 x 8	SAND	11		11		
16	SAND	20	1.6	17	12 x 8	CLAY	13		13		
						12 x 8	SAND	7		7	



REV. APP. DATE DESCRIPTION  
 DRAWN BY: A. ROCHA CHECKED BY:  
 APPROVED BY: *R. J. Cullen* 23797 12/22/88  
 CITY ENGINEER, R.C.E. DATE:

CITY OF MARTINEZ  
 PUBLIC WORKS DEPARTMENT  
 BLOCKING DETAIL

SCALE:  
 STD. DRWG.  
 NO.  
**W-7**  
 SHEET 2 OF 6

KRC  
12.21.84

WAFFER BUTTERFLY VALVE (SHOWN)  
OR FLANGED BUTTERFLY VALVE

FLANGE & R.T. ADAPTERS

FLANGES

WATER MAIN  
12" Ø

VALVE SUPPORTS —  
STEEL PLATES 1/2" THICK

FOR VALVE BOX INSTALLATION  
SEE STANDARD DRAWING NO. W-9

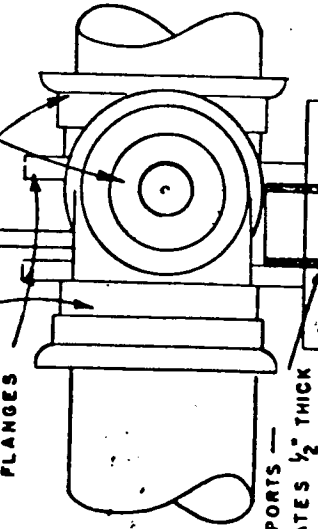

Ø 4 AT 6" —  
EACH WAY

2'0"

ELEVATION

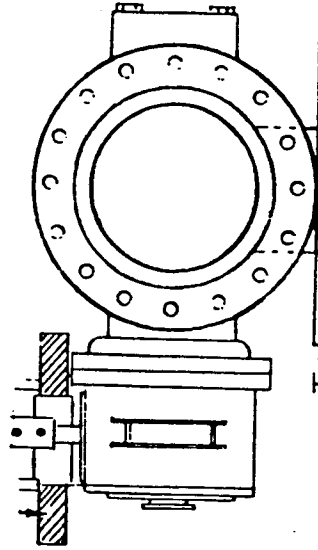

12" MIN

2'0"

CONCRETE PEDESTAL

SECTION

BUTTERFLY VALVES



REV.	APP.	DATE	DESCRIPTION
DRAWN BY: A. ROCHA			CHECKED BY:
APPROVED BY:			
P.R. Cullen 23797			12/22/84
CITY ENGINEER, R.C.E.			DATE:

CITY OF MARTINEZ  
PUBLIC WORKS DEPARTMENT

BLOCKING DETAIL

SCALE:  
STD. DRWG.  
NO.

W-7

SHEET 3 OF 2



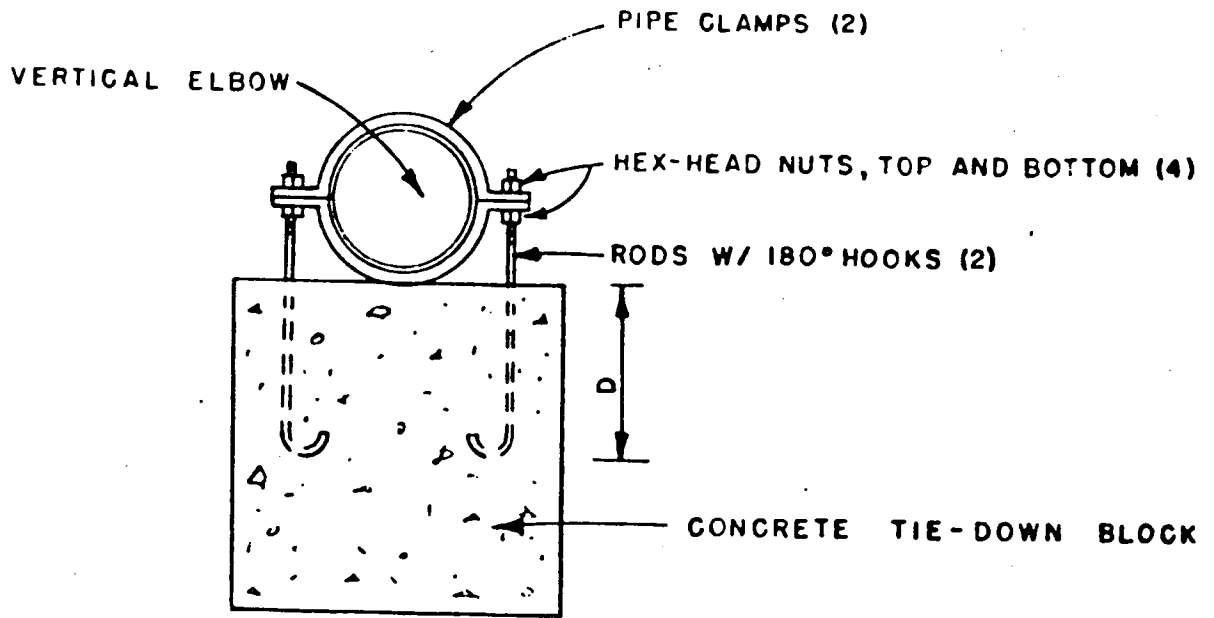

SECTION

TIE - DOWN BLOCKS

PIPE DIAM.	22- 1/2° ELBOWS			45° ELBOWS		
	RODS	"D"	BLOCK SIZE	RODS	"D"	BLOCK SIZE
4"	3/8"	6"	7 CU. FT.	3/8"	8"	14 CU. FT.
6"	3/8"	8"	15	3/8"	10"	29
8"	3/8"	10"	26	1/2"	14"	50
10"	1/2"	12"	42	5/8"	16"	82
12"	1/2"	14"	60	3/4"	18"	117
14"	5/8"	16"	80	7/8"	21"	159
16"	3/4"	18"	104 CU. FT.	1"	24"	206 CU. FT.

CONCRETE TIE-DOWN BLOCKS  
FOR VERTICAL ELBOWS

RRC  
12.24.83

	REV.	APP.	DATE	DESCRIPTION	CITY OF MARTINEZ PUBLIC WORKS DEPARTMENT  BLOCKING DETAIL	SCALE:	
	DRAWN BY: A. ROCHA					CHECKED BY:	STD. DRWG. NO.
	APPROVED BY: <i>R.P. Cullen</i>					23797 12/22/83	W-7
	CITY ENGINEER, R.C.E.					DATE:	SHEET 4 OF 5

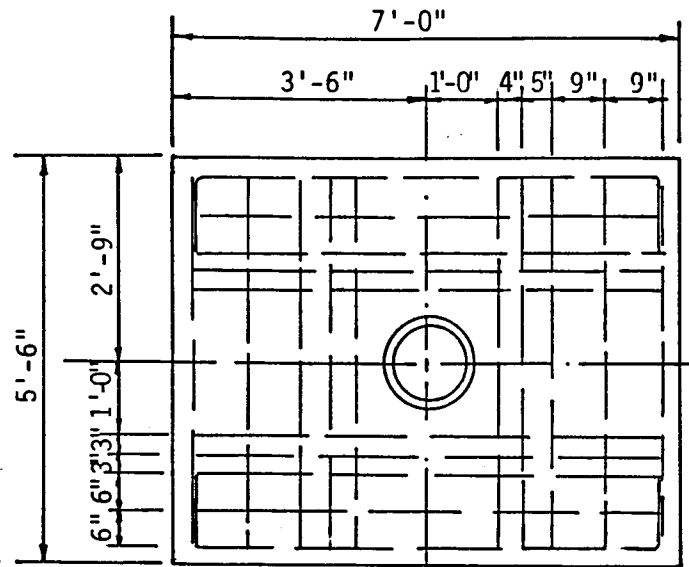

MAT 5

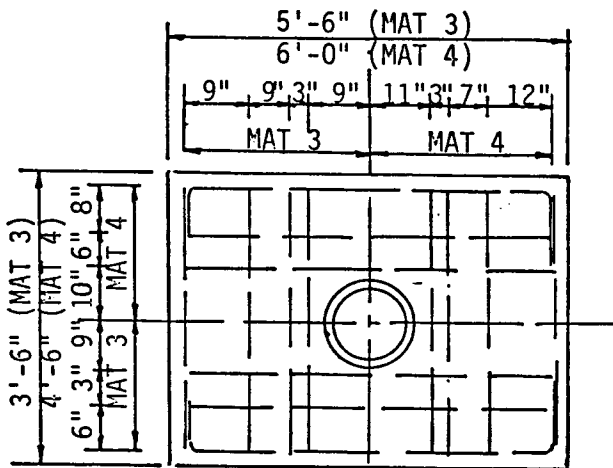

MATS 3 & 4

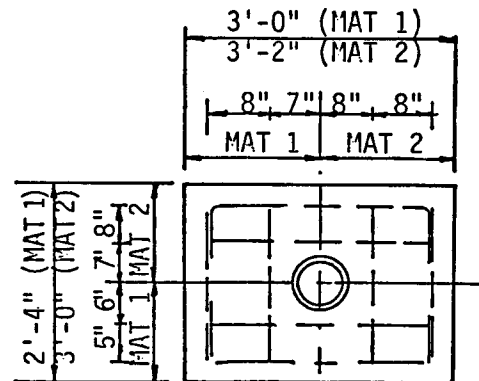

MATS 1 & 2

CONCRETE ANCHORS

PIPE SIZE	TIE ROD SIZE	DIMENSIONS			ANCHOR & MAT	STEEL IN MAT	CONCRETE IN MAT
		a	b	c			
4"	1/2"	4'-6"	1'-0"	6"	1	12 LBS.	1/4 CU. YDS.
6"	1/2"	5'-0"	1'-0"	6"	2	14 LBS.	3/8 CU. YDS.
8"	5/8"	6'-0"	1'-0"	6"	3	36 LBS.	3/4 CU. YDS.
10"-12"	7/8"	7'-9"	1'-0"	1'-3"	4	68 LBS.	1 CU. YDS.
14"-16"	1"	10'-0"	1'-3"	1'-6"	5	120 LBS.	1-3/4 CU. YDS.



REV. APP. DATE DESCRIPTION  
 DRAWN BY A. ROCHA CHECKED BY:  
 APPROVED BY: *R.R. Cullen* 23797 12/22/88  
 CITY ENGINEER, R.C.E. DATE:

CITY OF MARTINEZ  
 PUBLIC WORKS DEPARTMENT  
**BLOCKING DETAIL**

SCALE:  
 STD. DRWG.  
 NO.  
**W-7**  
 SHEET 5 OF 6

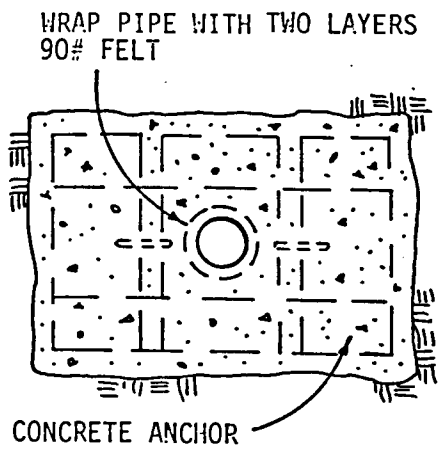
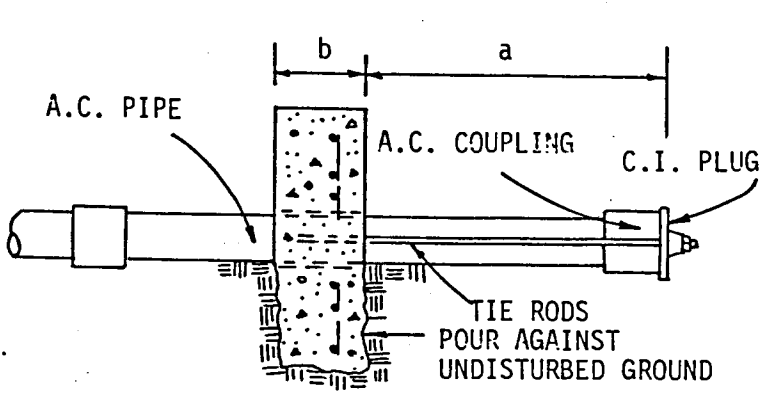
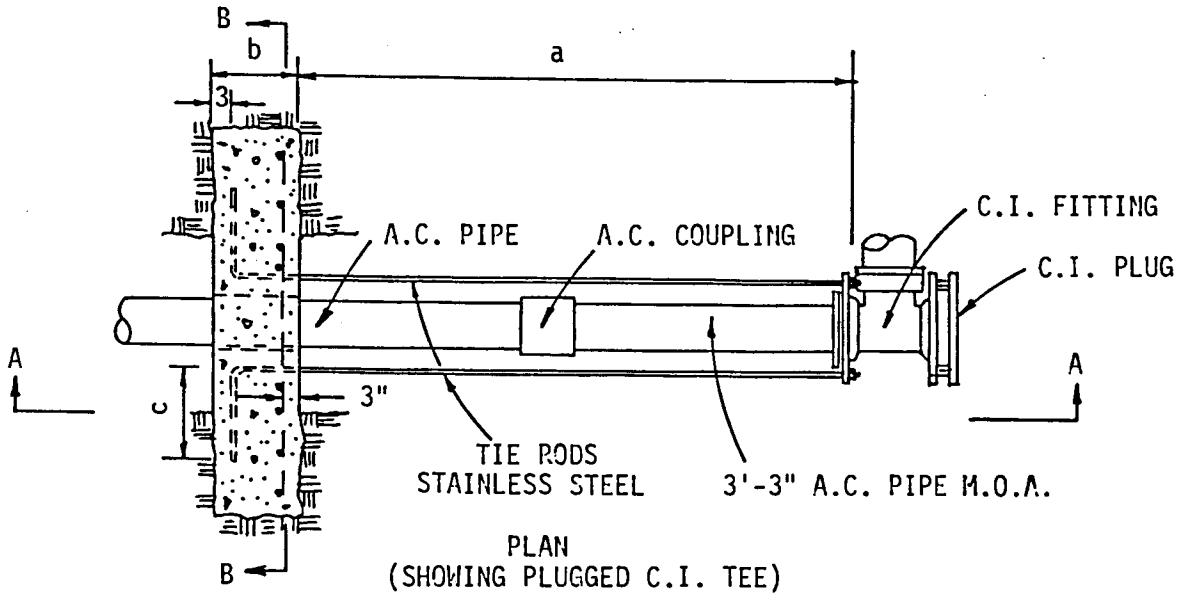

ANCHOR INSTALLATIONS FOR A.C. PIPE

NOTE: FOR DIMENSIONS a, b, AND c SEE SHEET 5 OF 6 STANDARD DRAWING W-7.

			CITY OF MARTINEZ PUBLIC WORKS DEPARTMENT		SCALE:	
	REV.	APP.	DATE	DESCRIPTION	STD. DRWG. NO.	
	DRAWN BY: A. ROCHA [CHECKED BY: ]				BLOCKING DETAIL	W-7
	APPROVED BY: <i>R.P. Cullen</i> 23797 12/22/88					SHEET 6 OF 6
CITY ENGINEER, R.C.E.				DATE:		

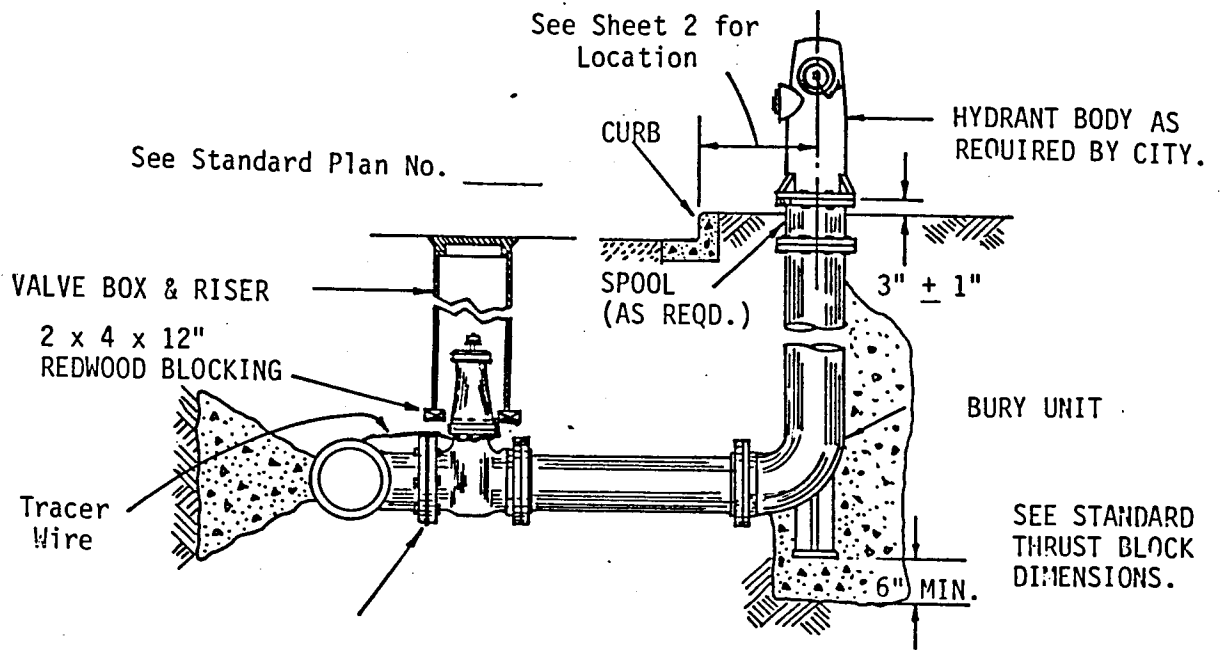

ELEVATION

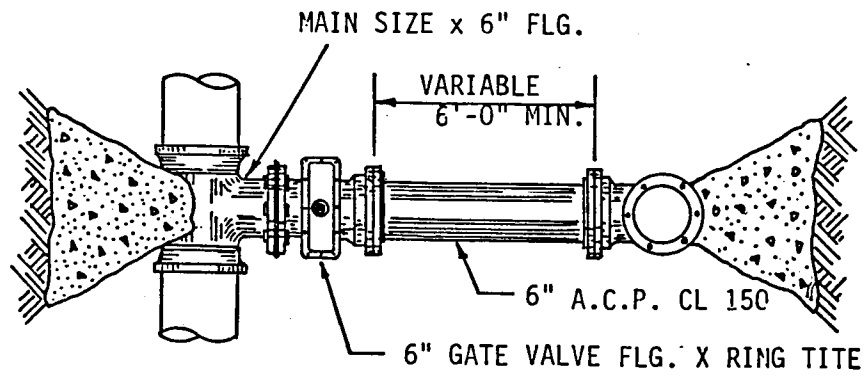

PLAN

MAIN INSTALLED IN STREET

NOTES:

1. FIRE HYDRANT INSTALLATIONS SHALL COMPLY WITH FIRE DISTRICT AND CITY REQUIREMENTS.
2. SEE DRAWING W-7 FOR THRUST BLOCK DETAILS
3. ENCASE ALL METALLIC SURFACES BELOW GROUND WITH POLYETHYLENE.

OK RRC 11/23/83

	<b>CITY OF MARTINEZ</b> <b>PUBLIC WORKS DEPARTMENT</b>	<b>SCALE:</b> <b>STD. DRWG.</b> <b>NO.</b> <b>W-8</b>									
	<table border="1" style="width: 100%;"> <tr> <th style="width: 25%;">REV.</th> <th style="width: 25%;">APP.</th> <th style="width: 25%;">DATE</th> <th style="width: 25%;">DESCRIPTION</th> </tr> <tr> <td> </td> <td> </td> <td> </td> <td> </td> </tr> </table>	REV.	APP.	DATE	DESCRIPTION					<b>STANDARD VALVE AND</b> <b>HYDRANT INSTALLATIONS</b>	<b>SHEET 1 OF 2</b>
	REV.	APP.	DATE	DESCRIPTION							
DRAWN BY: <i>A. [unclear]</i> APPROVED BY: <i>R.F. Cullen</i> CITY ENGINEER, R.C.E.	CHECKED BY: <i>[unclear]</i> DATE: <i>23/97 12/22/88</i>										

PLANTER AREA

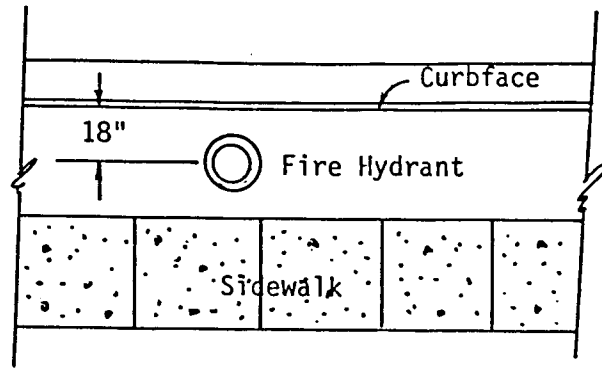

COMMERCIAL AREA  
6' AND WIDER SIDEWALK

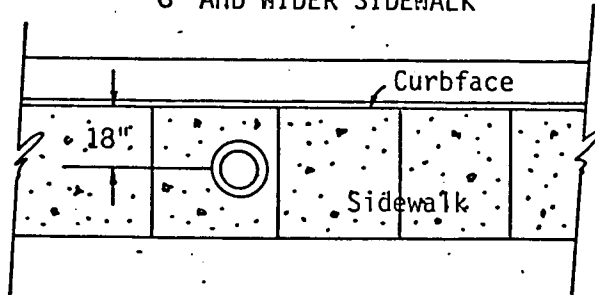

RESIDENTIAL/COMMERCIAL  
5 1/2' MONOLITHIC SIDEWALK

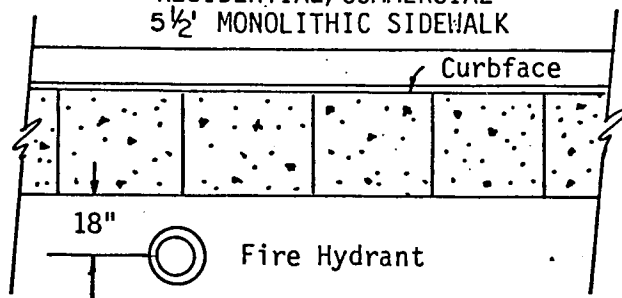

ROADSIDE AREA

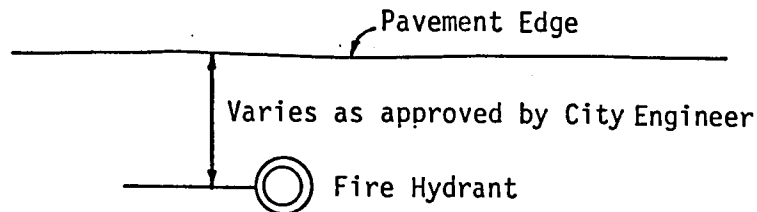

OK RRC 12-14-83

	REV.	APP.	DATE	DESCRIPTION	CITY OF MARTINEZ PUBLIC WORKS DEPARTMENT  STANDARD VALVE AND HYDRANT INSTALLATIONS	SCALE:
	DRAWN BY: A. ROCHA			CHECKED BY:		STD. DRWG. NO.
	APPROVED BY:			DATE:		W-8
	R. P. Cullen			23797 12/22/83		SHEET 2 OF 2
CITY ENGINEER, R.C.E.				DATE:		

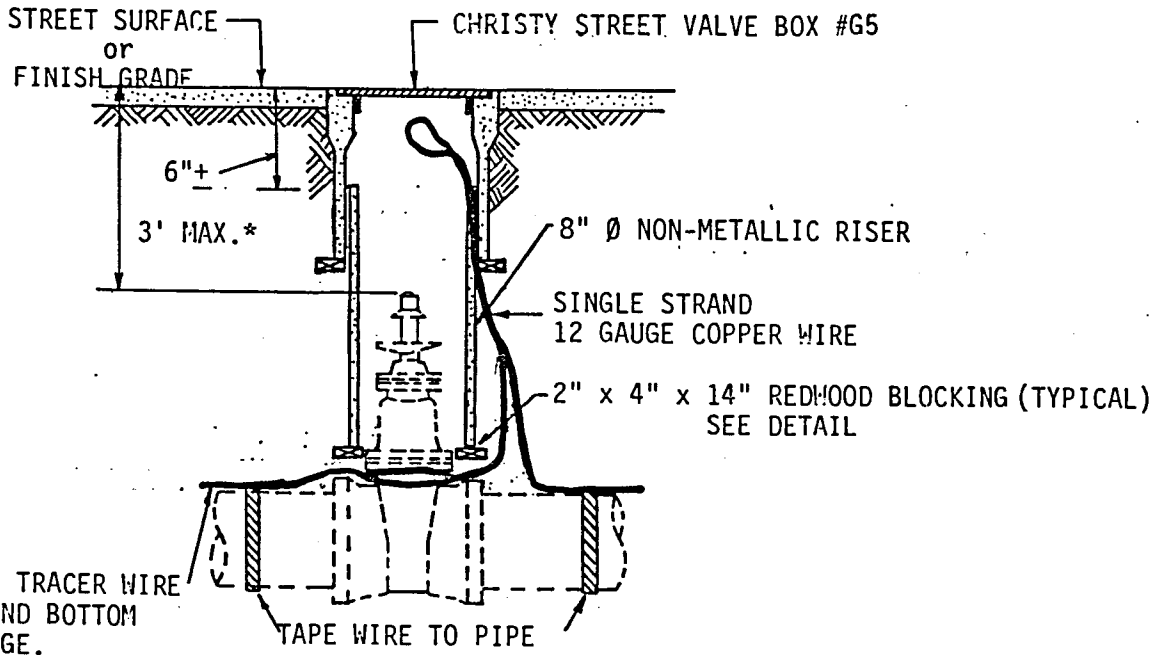

STANDARD VALVE & BLOW-OFF BOX  
INSTALLED IN TRAFFIC AREA

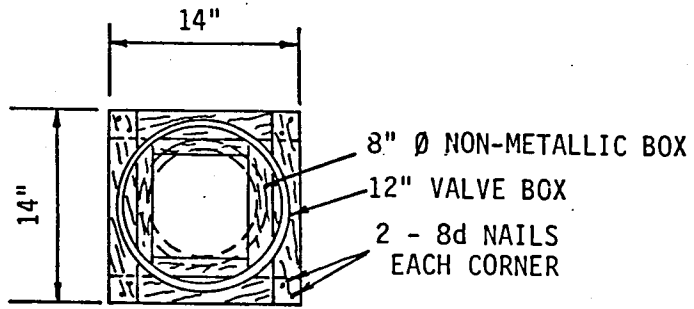

PLAN

REDWOOD BLOCKING  
DETAIL

\*NOTE: FOR DISTANCE EXCEEDING 3', DETAIL OF STEM EXTENSION SHALL BE SUBMITTED FOR APPROVAL BY THE CITY ENGINEER.

OK - KRC 12.8.83

	<table border="1"> <tr> <th>REV.</th> <th>APP.</th> <th>DATE</th> <th>DESCRIPTION</th> </tr> <tr> <td> </td> <td> </td> <td> </td> <td> </td> </tr> </table>	REV.	APP.	DATE	DESCRIPTION					<b>CITY OF MARTINEZ PUBLIC WORKS DEPARTMENT</b>	<b>SCALE:</b> STD. DRWG. NO. <b>W-9</b>
	REV.	APP.	DATE	DESCRIPTION							
	DRAWN BY: A. ROOHA APPROVED BY: <i>R.K. Cullen</i>	CHECKED BY: <i>23797</i> DATE: <i>12/22/83</i>	<b>STANDARD VALVE BOX</b>	<b>SHEET 1 OF 1</b>							
CITY ENGINEER, R.C.E.	DATE:										



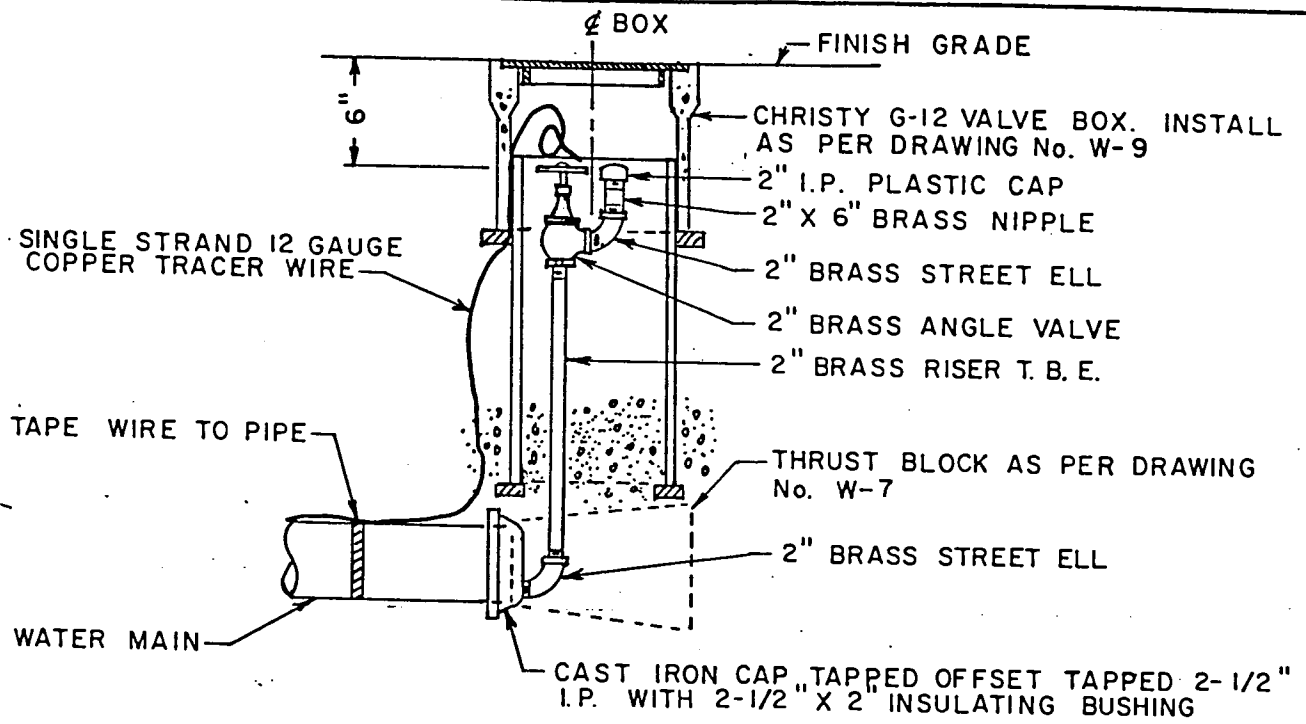

**TYPE 1 INSTALLATION**

MINIMUM TIE ROD SIZE	
6" PIPE	5/8" Ø
8" PIPE	3/8" Ø
12" PIPE	1" Ø

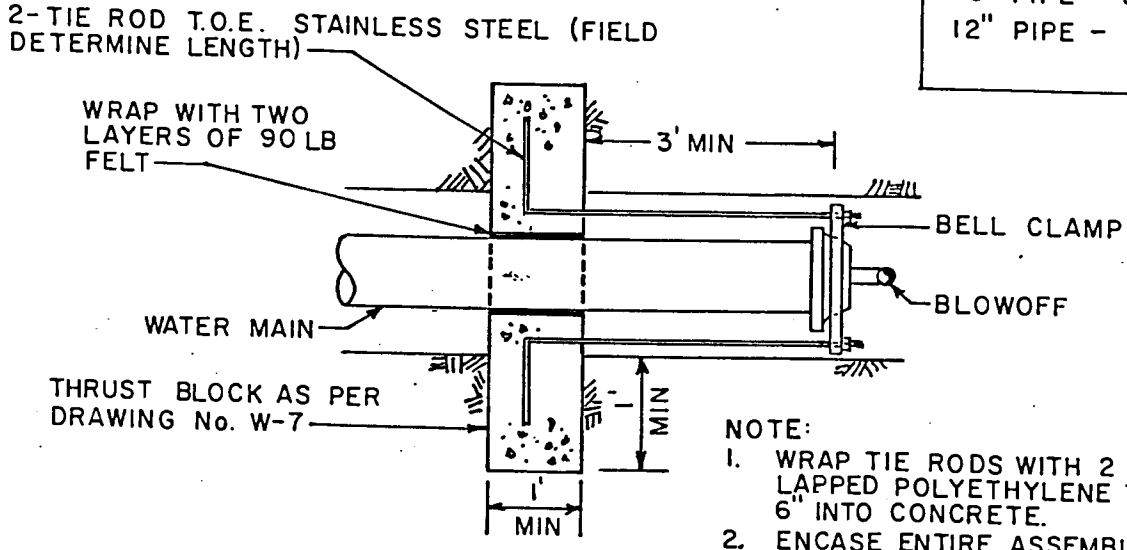

- NOTE:
1. WRAP TIE RODS WITH 2 LAYERS OF LAPPED POLYETHYLENE TAPE MINIMUM 6" INTO CONCRETE.
  2. ENCASE ENTIRE ASSEMBLY IN POLYETHYLENE.

**TYPE 2 INSTALLATION**

**2" BLOWOFF ASSEMBLY-END OF MAIN**

	REV.	APP.	DATE	DESCRIPTION	CITY OF MARTINEZ PUBLIC WORKS DEPARTMENT  <b>STANDARD BLOWOFF</b>	SCALE: NONE
	DRAWN BY: JC			CHECKED BY:		STD. DRWG. NO.
	APPROVED BY: <i>R.K. Cullen</i>			DATE: 12/22/88		<b>W-10</b>
	CITY ENGINEER, R.C.E.			DATE:		SHEET 1 OF 2



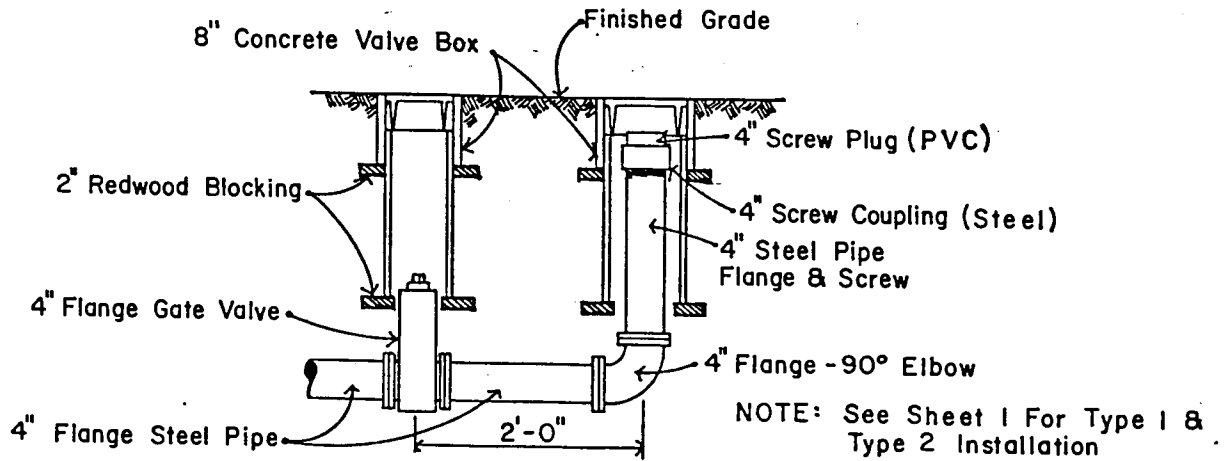

**4" BLOWOFF ASSEMBLY - END OF MAIN**

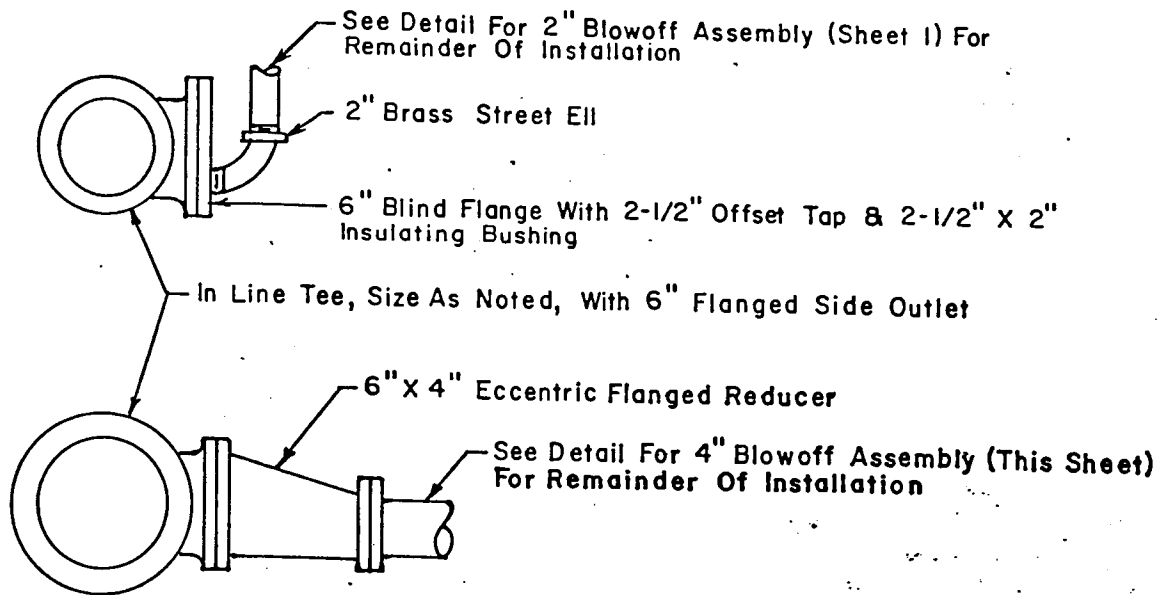

- NOTE: 1. In Line Blowoff Assembly To Be Installed At Sag Or Low Point In Main Line  
 2. All Bolts To Be Stainless Steel  
 3. Encase Assembly In Polyethylene  
 4. Concrete Thrust Block Per Drawing No. W-7

**2" & 4" BLOWOFF ASSEMBLY - IN LINE**

	REV.	APP.	DATE	DESCRIPTION	CITY OF MARTINEZ PUBLIC WORKS DEPARTMENT	SCALE: NONE	
	DRAWN BY: RENE			CHECKED BY: R.R.C.		STANDARD BLOWOFF	STD. DRWG. NO.
	APPROVED BY: <i>R.P. Cullen</i> 23797 12/22/88				CITY ENGINEER, R.C.E.		DATE: 12/22/88
						SHEET 2 OF 2	

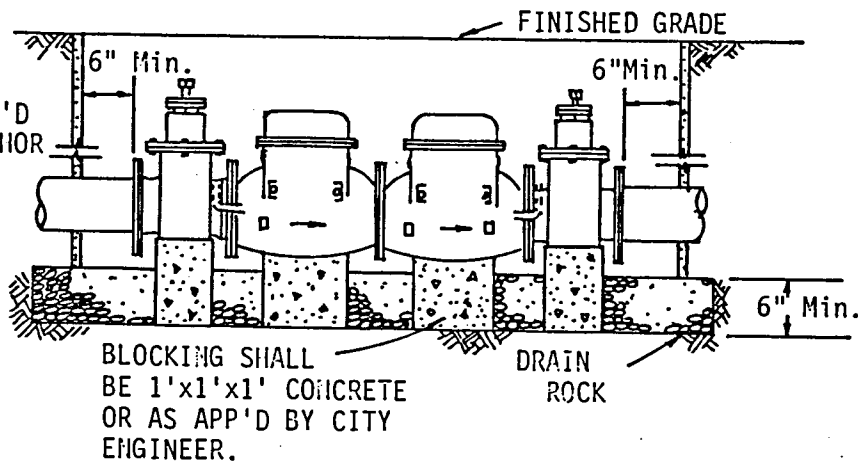
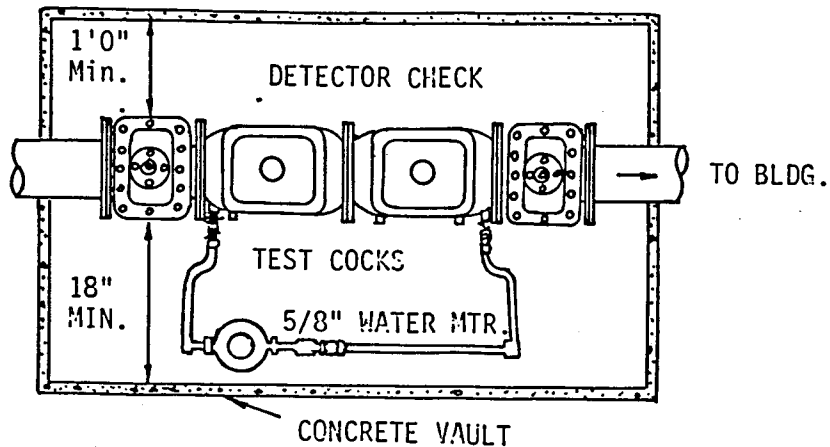

SEE STANDARD DRAWING FOR REQ'D BLOCKING OR ANCHOR DETAILS.

- NOTES:
1. DOUBLE CHECK VALVE DETECTOR CHECK ASSEMBLY SHALL BE INSTALLED ON CLASS III AND IV FIRE SERVICE
  2. DETECTOR CHECK ASSEMBLY SHALL BE INSTALLED IN AN ACCESSIBLE LOCATION TO FACILITATE TESTING AND REPAIRS.
  3. PROVIDE TRAFFIC COVERS FOR VAULTS IN AREAS WHERE VAULT WILL BE SUBJECTED TO VEHICULAR TRAFFIC.
  4. DETECTOR CHECK ASSEMBLY, (EXCEPT THE METER), SHALL BE THE PROPERTY OF THE CUSTOMER. THE CITY RESERVES THE RIGHT TO PERIODICALLY CHECK AND SERVICE THE ASSEMBLY.
  5. FOR LIST OF APPROVED CHECK VALVES, CONTACT THE WATER TREATMENT PLANT, 372-3588.
  6. REDUCED PRESSURE PRINCIPLE BACKFLOW ASSEMBLY IS REQUIRED INSTEAD OF CHECK ASSEMBLY IF A CHEMICAL IS INTRODUCED INTO FIRE LINE.
  7. READING LID SHALL BE LOCATED ABOVE DETECTOR METER.
  8. DETECTOR METER, ONLY, SHALL BE FURNISHED BY CITY.
  9. DOUBLE CHECK DETECTOR CHECK ASSEMBLY SHALL BE PURCHASED AS A SINGLE UNIT.
  10. FOR VAULT AND LID DETAILS, SEE STANDARD DRAWING W-5.

OK PRC 1.20.84

	CITY OF MARTINEZ PUBLIC WORKS DEPARTMENT		SCALE: STD. DRWG. NO.
	REV. APP. DATE	DESCRIPTION	DOUBLE CHECK VALVE - DETECTOR CHECK ASSEMBLY
	DRAWN BY: A. ROCHA (CHECKED BY:)		
	APPROVED BY: <i>R.P. Cullen</i> 23797 12/22/88 CITY ENGINEER, R.C.E. DATE:		
			SHEET 1 OF 1

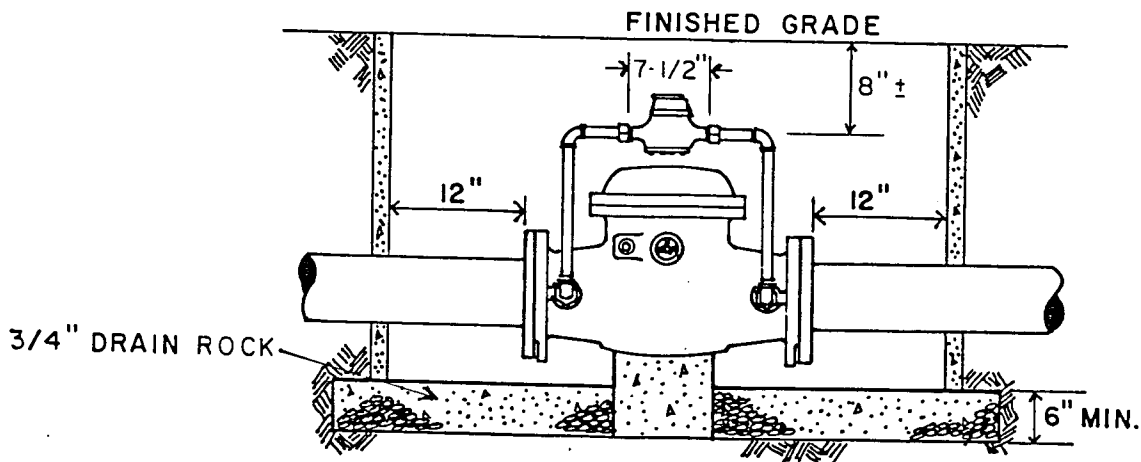
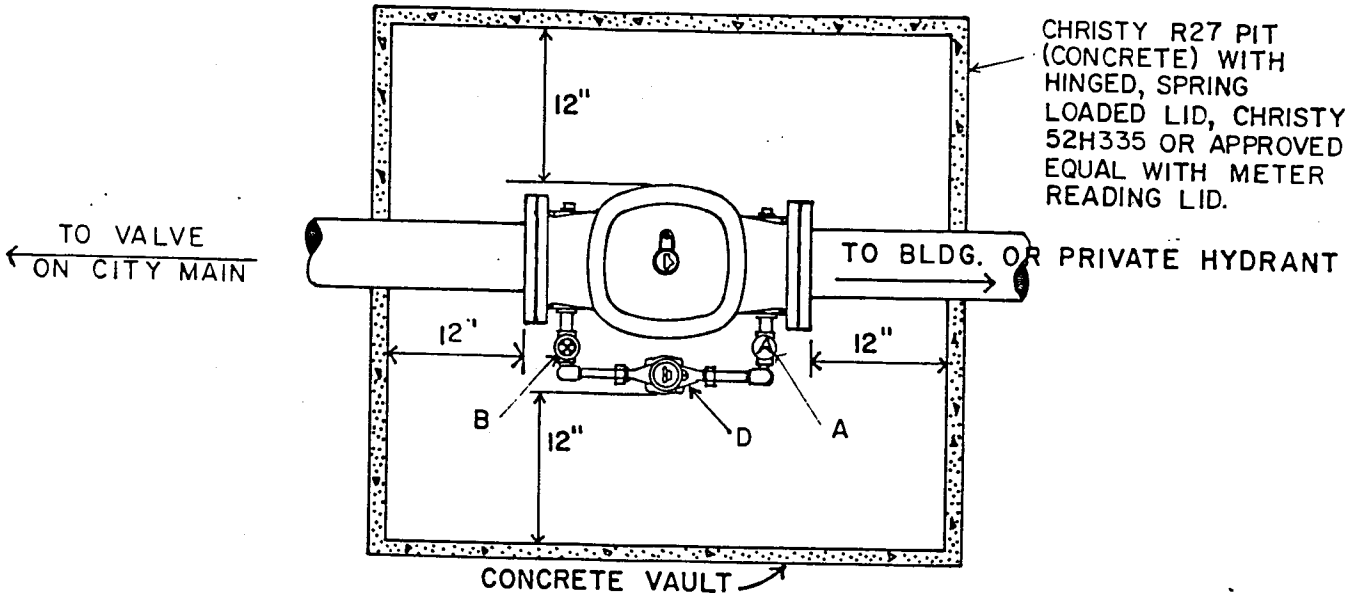

- (1) SINGLE CHECK VALVE DETECTOR CHECK ASSEMBLY SHALL BE INSTALLED ON CLASS I AND II FIRE SERVICE AND PRIVATE FIRE HYDRANT LINE.
- (2) DETECTOR CHECK TO BE LOCATED WITHIN RIGHT OF WAY OR CITY EASEMENT.
- (3) VAULTS WILL NOT BE ALLOWED IN AREAS WHERE VAULT MIGHT BE SUBJECT TO VEHICULAR TRAFFIC.
- (4) DETECTOR METER, ONLY, TO BE FURNISHED BY CITY.  
READING LID SHALL BE LOCATED ABOVE METER.

**MATERIALS LIST.**

- A. CHECK VALVE (DETECTOR METER LINE) FORD HA 31-323 (ANGLE), HS 31-323 OR HS 81-333.
- B. 3/4" CURB STOP.
- C. ALL TRIM MATERIALS TO BE BRASS / COPPER.
- D. CITY FURNISHED 5/8" X 3/4" DETECTOR METER



JC	9-91	REV. NOTE 3 - SPRING LID
REV. APP. DATE		DESCRIPTION
DRAWN BY: BENE BA	CHECKED BY:	
APPROVED BY: <i>P. P. Cullen</i>	23797	SEP 1991
CITY ENGINEER, R.C.E.		DATE:

CITY OF MARTINEZ  
PUBLIC WORKS DEPARTMENT

SINGLE CHECK VALVE -  
DETECTOR CHECK ASSEMBLY

SCALE: NONE
STD. DRWG. NO.
<b>W-12</b>
SHEET 1 OF 1

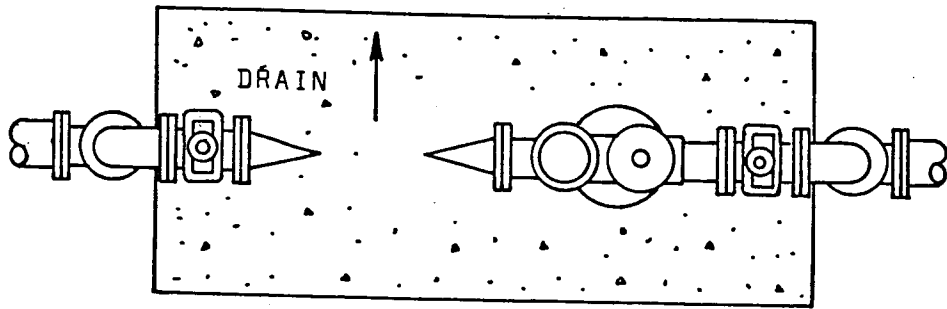

WIDTH OF CONCRETE PAD TO BE  
1" WIDER THAN ABOVE ASSY. ON  
EACH SIDE.

PLAN

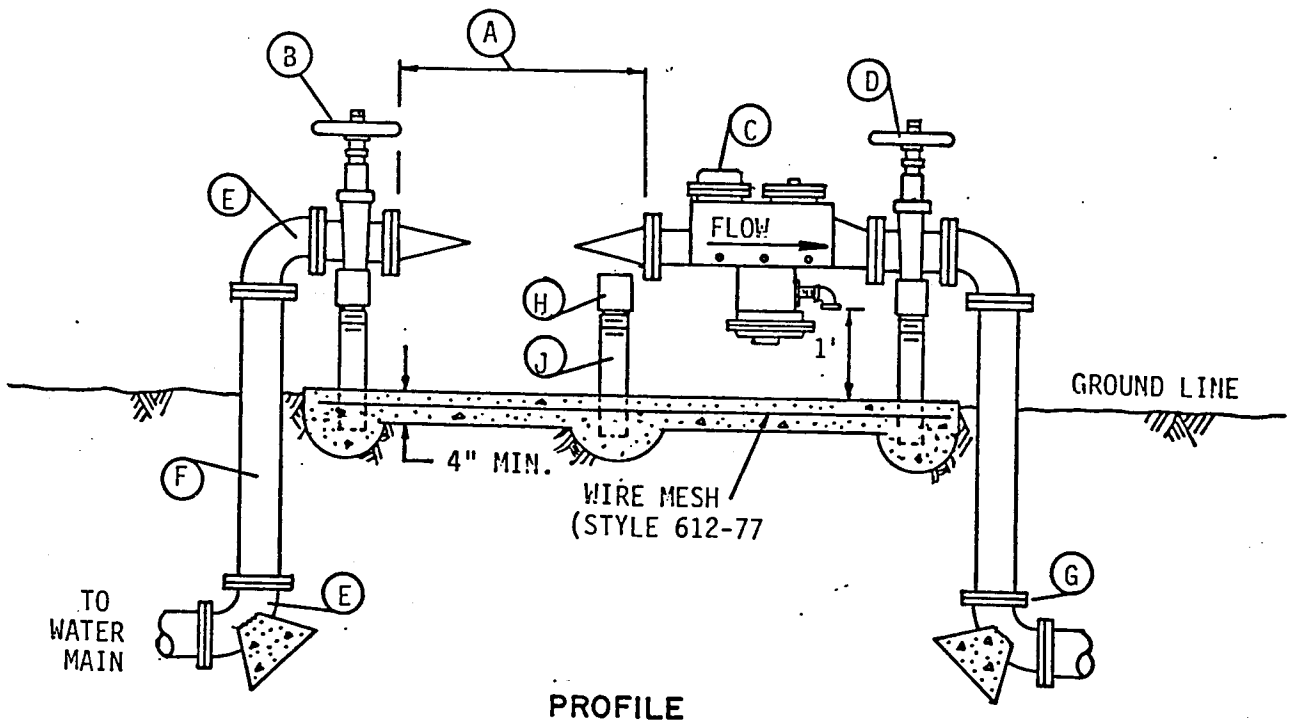

PROFILE

OK 12.14.03  
RAC

	REV.	APP.	DATE	DESCRIPTION	CITY OF MARTINEZ PUBLIC WORKS DEPARTMENT <b>3" &amp; LARGER REDUCED          PRESSURE BACKFLOW          PREVENTION DEVICE          INSTALLATION</b>	SCALE:
	DRAWN BY: A. POCHA			CHECKED BY:		STD. DRWG. NO.
	APPROVED BY: <i>F.R. Cullen</i>			23797 12/22/02		<b>W-13</b>
	CITY ENGINEER, R.C.E.			DATE:		SHEET 1 OF 2

LIST OF MATERIAL

ITEM	QTY	DESCRIPTION SERVICE
A	1	METER ASSY. (SIZE AND TYPE AS REQUIRED)
B	1	GATE VALVE FLG. (WITH HANDWHEEL,
E	4	ELL 90° FLG.
F	2	CAST IRON PIPE F.B.E.
G	1	INSULATING GASKET SET (TYPICAL)
H	2	4" CPLG. SS, GALV.
J	2	4" PIPE GALV. T.O.E. (18" LONG)
	8	FLG. HARDWARE SET
REDUCED PRESSURE BACKFLOW PREVENTER ASSY.		
C	1	REDUCED PRESSURE BACKFLOW PREVENTER (APPROVED STYLE)
D	1	GATE VALVE FLG. (WITH HANDWHEEL)
H	1	4" CPLG. SS, GALV.
J	1	4" PIPE GALV. T.O.E. (18" LONG)
	2	FLG. HARDWARE SET

NOTES:

1. SEE APPROPRIATE STANDARD DETAIL DRAWING FOR METER.
2. BACKFLOW PREVENTION DEVICES SHALL BE INSTALLED IN AN ACCESSIBLE LOCATION TO FACILITATE TESTING AND REPAIRS.
3. BACKFLOW PREVENTION DEVICES SHALL BE WITHIN A PROTECTIVE ENCLOSURE. SEE NOTE \_\_\_\_\_, STANDARD PLANS.
4. SECONDARY BY-PASS LINE AND ACCESSORIES TO BE INSTALLED AT CERTAIN INSTALLATIONS AS REQUIRED BY CITY ENGINEER.
5. APPROVED BACKFLOW PREVENTION DEVICES CONTACT THE WATER TREATMENT PLANT AT 372-3588.
6. THE CITY RESERVES THE RIGHT TO PERIODICALLY TEST AND SERVICE THE DEVICES.

OK RRC  
12.14.03

	REV.	APP.	DATE	DESCRIPTION	CITY OF MARTINEZ PUBLIC WORKS DEPARTMENT 3" & LARGER REDUCED PRESSURE BACKFLOW PREVENTION DEVICE INSTALLATION	SCALE:
	DRAWN BY: A. Rocha			CHECKED BY:		STD. DRWG. NO.
	APPROVED BY: R. R. Cullen			DATE: 12/22/02		W-13
CITY ENGINEER, R.C.E.				DATE:		SHEET 2 OF 2

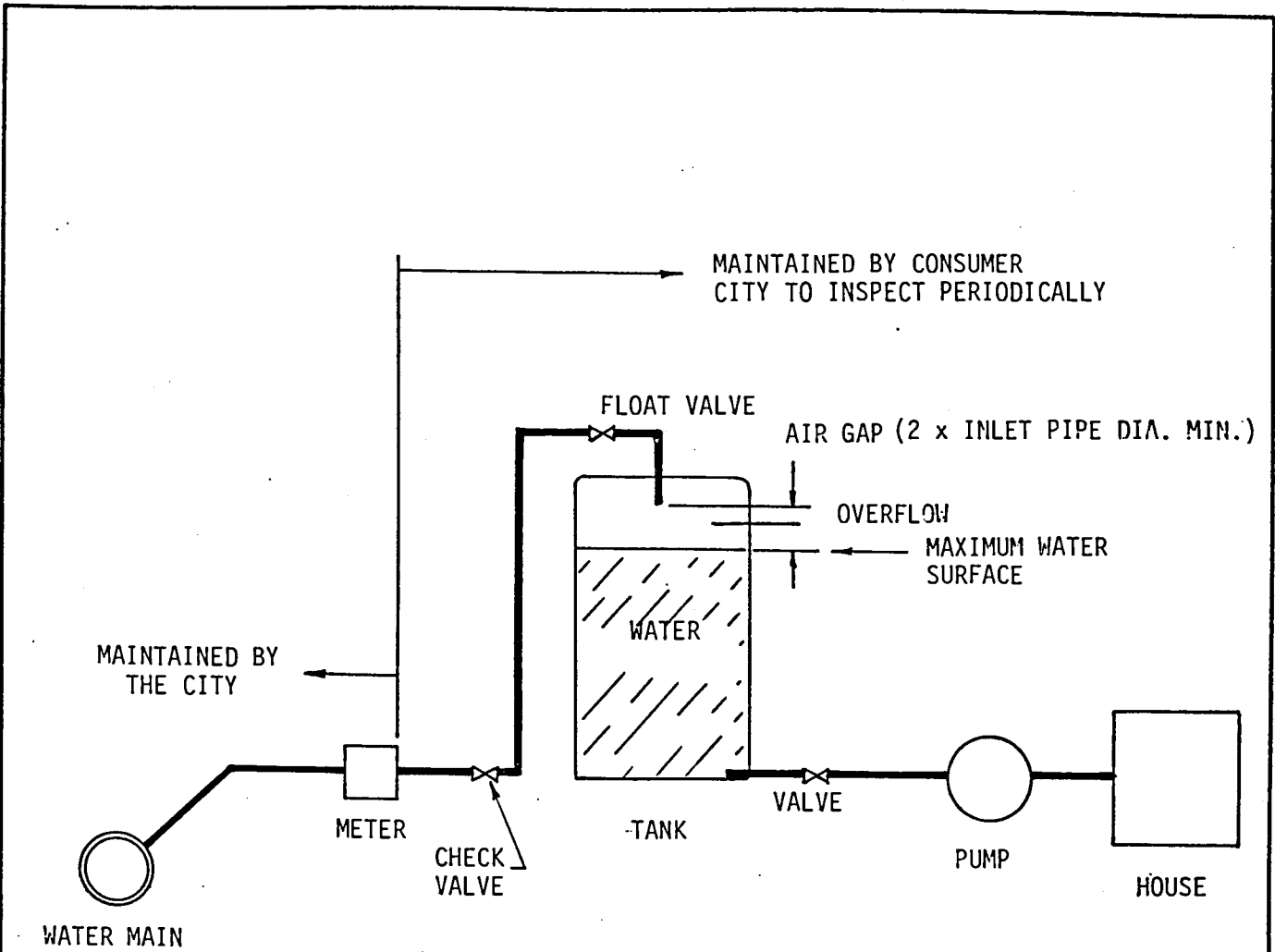

- NOTES:
1. AIR GAP INSTALLATION TO BE INSPECTED BY CITY.
  2. SUBMIT DETAILS OF INSTALLATION FOR REVIEW.
  3. INSTALLATION SHALL BE CERTIFIED BY REGISTERED DESIGN ENGINEER.

OK 12-14-83  
RAC

	REV.	APP.	DATE	DESCRIPTION	CITY OF MARTINEZ PUBLIC WORKS DEPARTMENT  <b>SCHEMATIC          BOOSTER PUMP          INSTALLATION</b>	SCALE:
	DRAWN BY:		CHECKED BY:			STD. DRWG. NO.
	APPROVED BY:		DATE:			<b>W-14</b>
	CITY ENGINEER, R.C.E.					SHEET <u>1</u> OF <u>1</u>

VALVE BOX - SEE DRWG. W-9  
FOR STANDARD INSTALLATION

2" BLOWOFF. SEE DRWG. W-10  
FOR TYPICAL INSTALLATION

FLNG X PUSH-ON  
VALVE, SIZE AS  
REQUIRED (2 EACH)

2" BRASS  
RISER

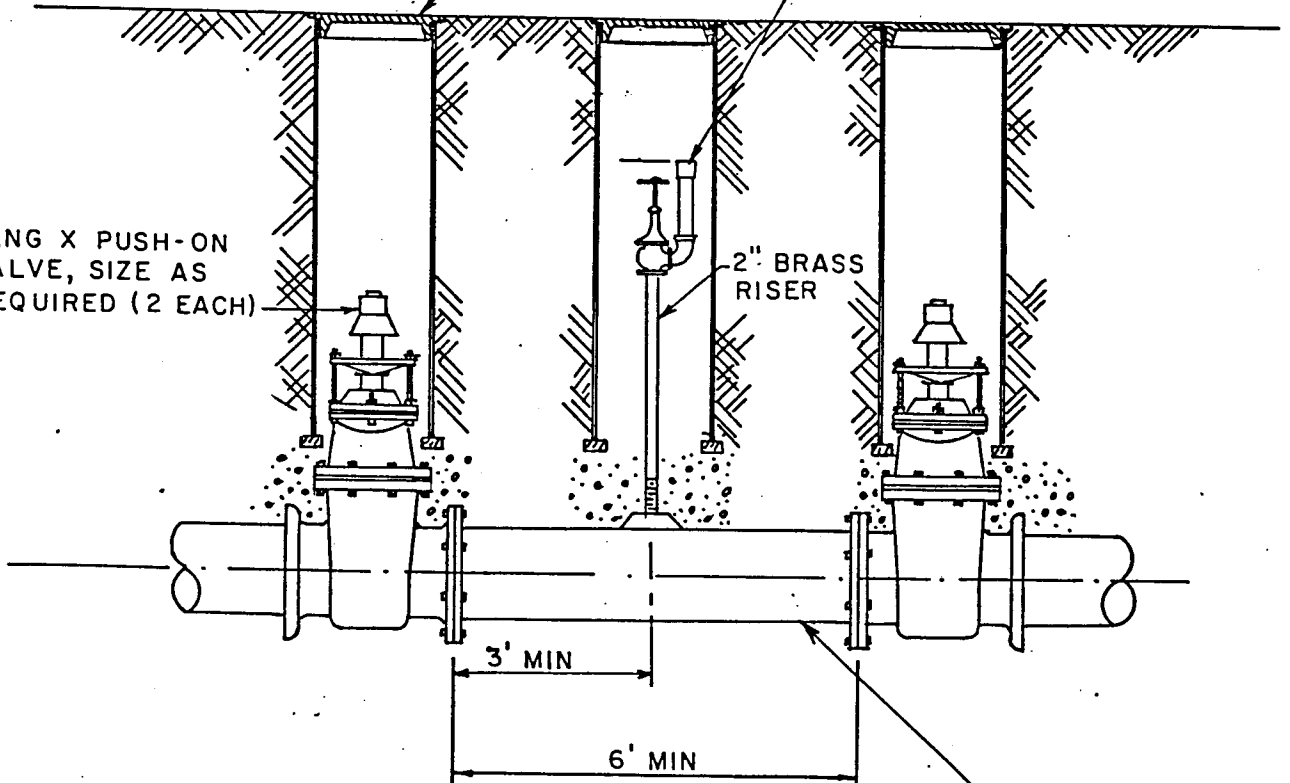

3' MIN

6' MIN

FLNG DUCTILE IRON SPOOL  
WITH FACTORY INSTALLED  
2-1/2" BOSS. INSTALL 2-1/2"  
X 2" DIELECTRIC BUSHING.

NOTE: BOTH VALVES NORMALLY CLOSED.



REV.	APP.	DATE	DESCRIPTION
DRAWN BY:		CHECKED BY:	
APPROVED BY:		DATE:	
<i>R. P. Cullen</i>		23797 12/22/88	
CITY ENGINEER, R.C.E.			

CITY OF MARTINEZ  
PUBLIC WORKS DEPARTMENT

ZONE VALVE  
ASSEMBLY

SCALE:  
STD. DRWG.  
NO.  
**W-15**  
SHEET 1 OF 1

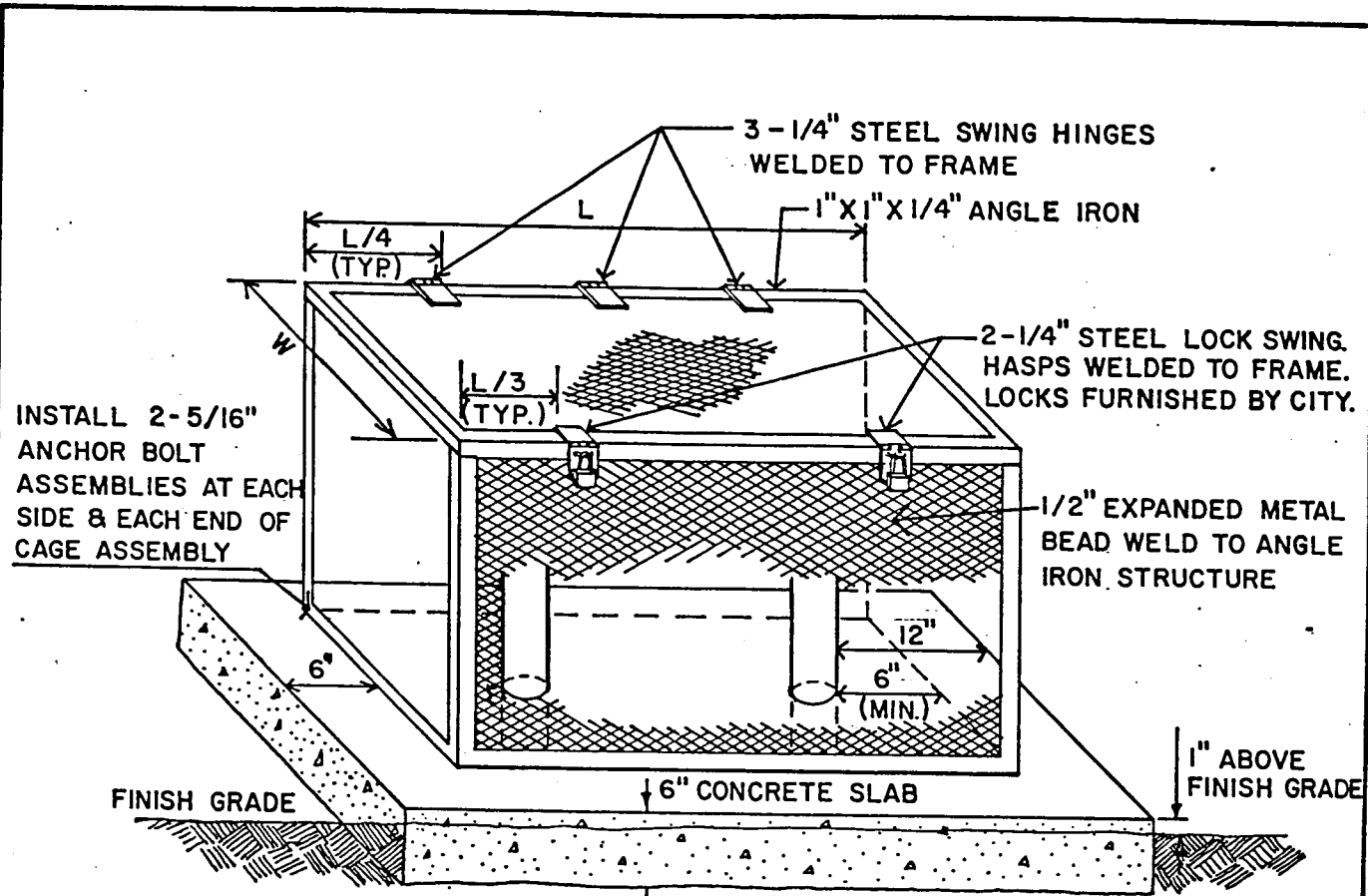

INSTALL 2-5/16\"/>

3-1/4\"/>

1\"/>

2-1/4\"/>

1/2\"/>

FINISH GRADE

6\"/>

1\"/>

**NOTES:**

1. PROVIDE SHOP DRAWINGS FOR APPROVAL.
2. PAINT UNIT WITH 2 COATS OF PRIMER AND 1 COAT OF EXTERIOR BLACK ENAMEL.
3. FOR LENGTH UNDER 5'. USE 2 HINGES AND 1 HASP.

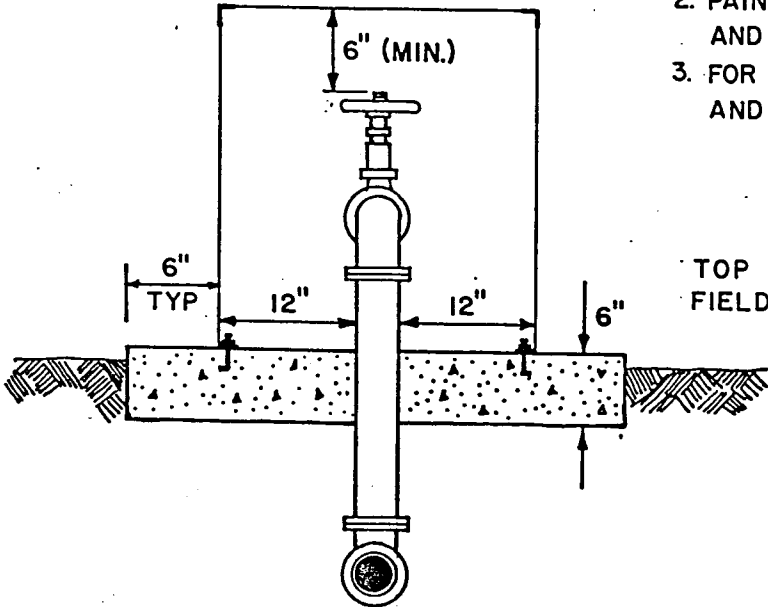

TOP RESTRAINING CHAIN FIELD CUT TO FIT

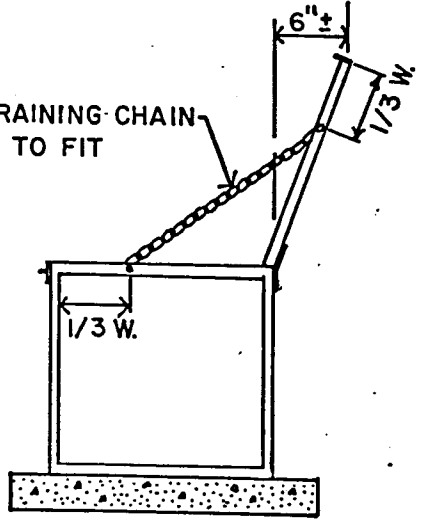

*OK RRC 9.6.84*

	7-84	CITY OF MARTINEZ PUBLIC WORKS DEPARTMENT	SCALE:	
	REV. APP. DATE	DESCRIPTION	STD. DRWG. NO.	
	DRAWN BY: RENG	CHECKED BY: R.R.C.	<b>W-16</b>	
	APPROVED BY: <i>R.R. Cullen</i>	23797 12/2/88	SHEET ___ OF ___	
CITY ENGINEER, R.C.E.		DATE:		

**PROTECTIVE ENCLOSURE**



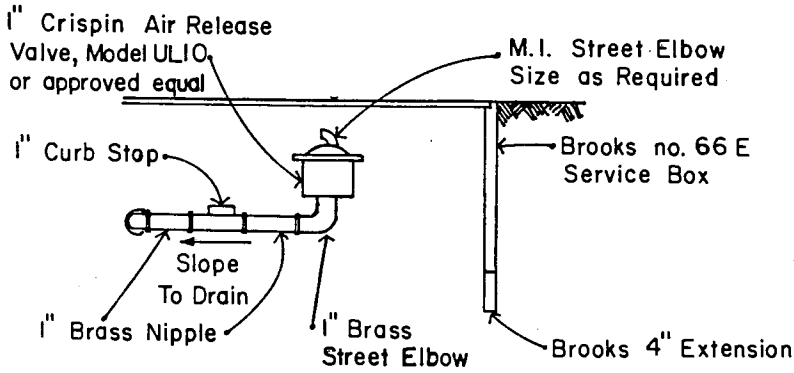

**SECTION A-A**

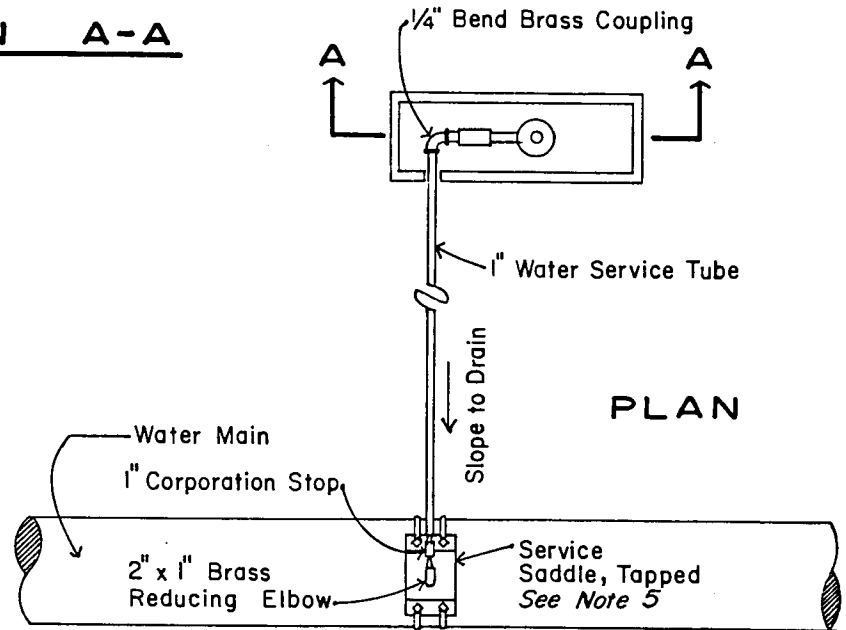

**AIR & VACUUM RELIEF VALVE ASSEMBLY**

**NOTES:**

1. All underground steel pipes shall be enclosed within a min. of 8-mil thick polyethylene encasement, & be carefully secured with 10-mil thick tape.
2. Place box behind & adjacent to sidewalk or in location similar to nearby water meter boxes.
3. Service box shall have 3" min. crushed rock bottom.
4. Steel pipe shall be tapped in accordance with the manufacturer's recommendations, Tap shall be made 2-1/2" with 2-1/2" x 2" insulated bushing.
5. Bronze service saddle shall be used with non-metallic (PVC) pipe, tapped 2". Malleable iron service saddle shall be used with ductile iron pipe. Iron saddle shall be tapped 2-1/2" with 2-1/2" x 2" insulated bushing.

	VS	12-91	REMOVE BOLTED COVER	<b>CITY OF MARTINEZ</b> PUBLIC WORKS DEPARTMENT	SCALE: NONE
	JC	9-91	UNIVERSAL VALVE & ADD NOTE 5		STD. DRWG.
	REV. / APP. / DATE	DESCRIPTION		<b>AIR &amp; VACUUM RELIEF VALVE ASSEMBLY</b>	NO.
	DRAWN BY: <i>BENE</i>	CHECKED BY: <i>RRG</i>			W-17
APPROVED BY: <i>R.P. Cullen</i>	23797	DEC 1991	CITY ENGINEER, R.C.E.	DATE:	SHEET <u>1</u> OF <u>1</u>

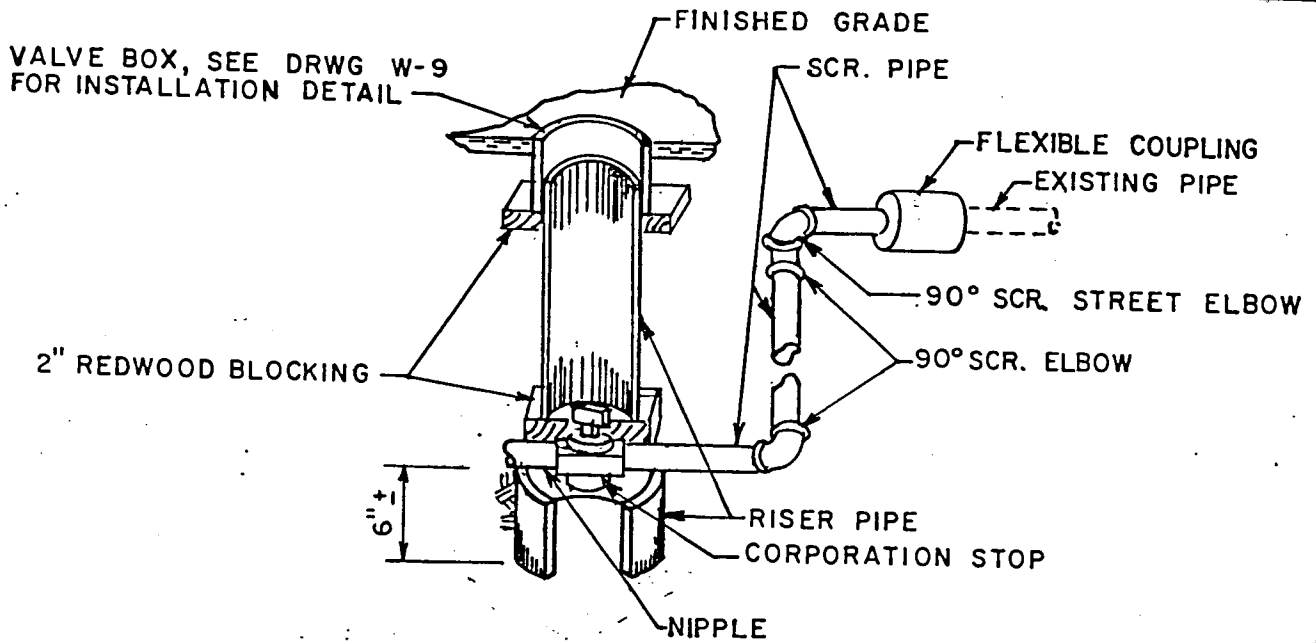

TYPE A INSTALLATION

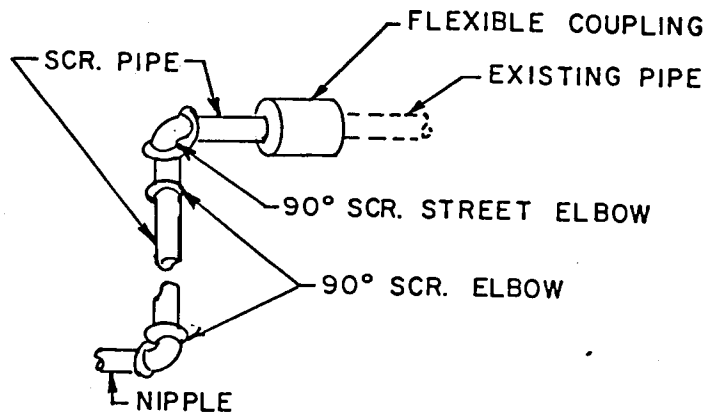

TYPE B INSTALLATION

NOTE: NEW PIPE & FITTINGS SHALL BE THE SAME SIZE AS EXISTING PIPE.

	REV.	APP.	DATE	DESCRIPTION	CITY OF MARTINEZ PUBLIC WORKS DEPARTMENT	SCALE: NONE STD. DRWG. NO. <b>W-18</b>
	DRAWN BY: JC		CHECKED BY:			
	APPROVED BY: <i>E.R. Cullen</i> 23797 12/22/88				SWING CONNECTION TO 4" & SMALLER EXISTING PIPE	SHEET 1 OF 1
	CITY ENGINEER, R.C.E.			DATE:		

# BACKFLOW PREVENTION DEVICE

## Typical Installations

Pit Installation (Top View)  
(Sizes 3/4" through 2")

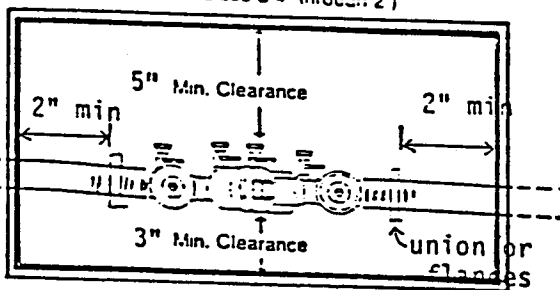

Febc 805  
Hersey FDC

Pit Installation (Top View)  
(Sizes 3/4" through 2")

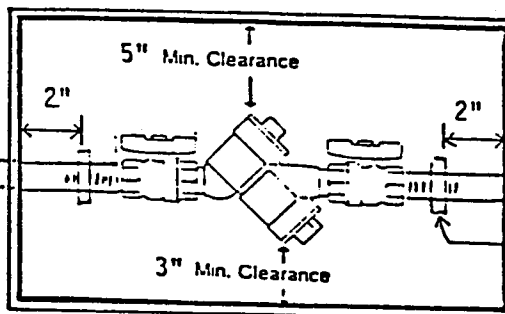

Febc 805Y / Wilkens 550

Pit Installation (Side View)  
(Sizes 3/4" through 2")

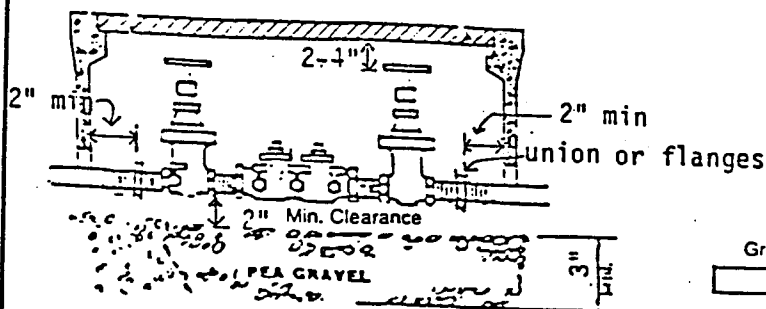

Outside Installation (Side View)  
(Sizes 3/4" through 2")

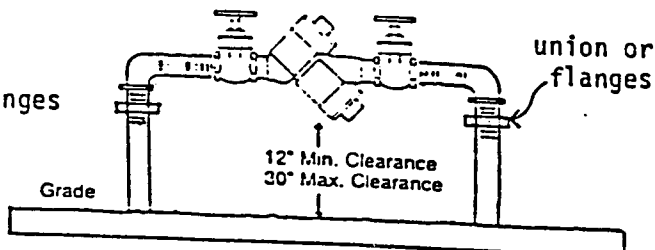

1. Typical backflow prevention device installation shall be back of sidewalk, immediately adjacent to the water meter, and above ground. There shall be no SECONDARY CONNECTIONS BETWEEN water meter and the backflow prevention device.
2. Entire assembly shall be purchased and installed as a complete unit. Backflow prevention devices shall be from City of Martinez's "List of Approved Backflow Prevention Devices" and meet AWWA and USC Foundation standards.
3. Double Check Valve Assembly (DCVA) may be installed in a pit if it is in a traffic area. All backflow prevention devices that are installed in an area where vehicles have access shall have at least two 2 1/2" diameter posts installed vertically, adjacent to the backflow device, to prevent vehicles from parking on or driving over the backflow prevention device.
4. 3/4" thru 2" backflow prevention devices shall have full flow ball valve shut offs.
5. Screwed installation shall have one union or set of flanges on each side of the backflow prevention device in an accessible location. Pipe shall be brass between meter and backflow prevention device. The union/flange material shall be compatible with backflow prevention device and piping material.
6. Meter box and cover for pit installation shall be Christy Products or approved equal. Size shall be as listed below (for DCVA only):

3/4" and 1" DCVA - Christy B-30  
1 1/2" and 2" DCVA - Christy B-36



REV.	APP.	DATE	DESCRIPTION
DRAWN BY:		CHECKED BY:	
APPROVED BY:		DATE:	
R. K. Cullen		23797 12/22/88	
CITY ENGINEER, R.C.E.			

CITY OF MARTINEZ  
PUBLIC WORKS DEPARTMENT  
3/4" TO 2" INSTALLATIONS  
BACKFLOW PREVENTION  
DEVICE

SCALE:  
STD. DRWG.  
NO.  
W-19  
SHEET 1 OF 1